

## NOTICE

### **Municipal Services Committee** Regular Meeting Tuesday, June 29th, 2021 at 5:00 pm

Due to social distancing guidelines this meeting will be conducted via web conference at: [meet.google.com/wje-xuct-mbr](https://meet.google.com/wje-xuct-mbr). The public may also use the teleconference option at +1 (315)-801-9407 then enter conference pin: 863 831 330#

## AGENDA

1. Call meeting to order
2. Roll call.
3. Civility Reminder
4. Motion to approve the agenda as presented.
- Pg 3-11 5. Motion to waive the reading and approve the minutes as printed from the May 25th, 2021 regular Municipal Services Committee meeting.
- Pg 12 6. Motion to waive the reading and approve the minutes as printed from the June 1<sup>st</sup>, 2021 Special Municipal Services Committee meeting.
7. Citizen appearances other than agenda items.
  -
8. Review of sanitary sewer billing adjustments. (Jan, Apr, Jul, Oct)  
Motion to approve a sewer credit in the amount of \$998.30 for account 17-1500-00  
Motion to approve a sewer credit in the amount of \$830.80 for account 30-6601-00
9. Director's Report
  - a. Parks and Recreation Report
  - b. Emergency Action Plan Addition - Load Shedding
  - c. Water Rate Case (Placeholder)
  - d. EPA Water Risk & Resilience Assessment / Emergency Response Plan
  - e. AMI Project (Placeholder)  
(1) Current AMI count remaining- Elec: **0** Water: 263
  - f. Lake Leota Dam Repair Update (Placeholder)
  - g. Municipal Services building expansion progress report.
    - Pg 13-388 • Motion to recommend to Common Council the contract with 1848 Construction.
    - Pg 389-399 • Sketchworks Architecture office space design proposal discussion
  - h. Dog Park Fence Update
  - i. W&L adjacent property (6936 N Old Hwy 92)
10. City Engineer Report

- a. Sub-division / Development Update
- b. Inflow and Infiltration Study (Placeholder)
- c. Roadway construction & other project updates. (Placeholder)
  - First & Second St Projects
  - Sidewalks

#### 11. Administrative Staff's Report

- Pg 400-405 a. Discussion and motion to recommend to Council approval of the contract with Ehlers Public Finance Advisors for a Stormwater Utility Rate Study.
- Pg 406 b. Non-Collectable Utility Accounts Review (Placeholder)
- c. West Side Park Progress (Placeholder)

#### 12. WPPI

- Pg 407 a. Amy Wanek – ESR Report

#### 13. Old Business

- Youth Center Update
- Holiday Lights

#### 14. New Business

15. Upcoming Meeting Date, July 27<sup>th</sup>, 2021 at 5:00 pm

#### 16. Adjourn

James Brooks, Committee Chair

*Please turn off all cell phones and electronic devices before meeting commences. If you have any special accessibility issues, please contact Evansville City Hall at 608-882-2266 prior to the scheduled meeting. Thank you.*

## NOTICE

**Municipal Services Committee**  
Regular Meeting  
Tuesday, May 25th, 2021 at 5:00 pm

Due to social distancing guidelines this meeting will be conducted via web conference at: [meet.google.com/wje-xuct-mbr](https://meet.google.com/wje-xuct-mbr). The public may also use the teleconference option at +1 (315)-801-9407 then enter conference pin: 863 831 330#

## MINUTES

### **1. Call meeting to order**

Brooks called the meeting to order at 5:01 pm

### **2. Roll call.**

Committee Chair Jim Brook and Gene Lewis were in attendance. Also in attendance were: Amy Wanek, Donna Hammett, Bill Hurtley, Jason Sergeant, Bill Lathrop, Nick Bubolz. Ben Ladick arrived at 5:29pm.

### **3. Civility Reminder**

### **4. Motion to approve the agenda as presented.**

Brooks/Lewis Motion approved 2-0

### **5. Motion to waive the reading and approve the minutes as printed from the April 27th, 2021 regular Municipal Services meeting.**

Brooks/Lewis approved 2-0

### **6. Citizen appearances other than agenda items.**

None

### **7. Review of sanitary sewer billing adjustments. (Jan, Apr, Jul, Oct)**

Renly stated that there would be two larger adjustments that will be brought before the Committee for their approval at June's meeting.

### **8. Director's Report**

#### **a. Parks and Recreation Report**

Renly stated that the Upper Shelter Bathroom is closed for repair. There is a 1" line, and the toilets are direct flush, discovered that when one of the faucets are on and flush the toilet, we lose water pressure. This shouldn't be happening with a 1" line. Renly is going to touch base with Hurst Plumbing, thinking about putting in a 2" line or possibly replacing the toilets. Summer help at the park in the next couple of weeks, the grass is getting high, and there is work going on the ball diamonds. Meeting with owner of Badger Pool to see what options they propose. The pool is losing water at a rate of 8.65 gallons a minute. He had a couple of ideas and Renly

told them his idea which would be very similar to what they would do. If Badger Pool does the work to fix the leaks that were found, the cost would be between \$15,000 and \$20,000. We found some significant holes that were hidden behind the caulking in between the joints, there is one really big one on the back part of the dive well. Badger Pool wouldn't be able to do the repairs until August. Renly's idea is to use butle tape (rubberized tape). We would put the tape on the joints leaking water and then put liquid rubber over it (not sure how tape will react to the chlorine), it is not going to look pretty but it should work. The pool will need to be dry and we will need to remove the paint.

Brooks asked if there were holes that were not fixed last year, Renly stated that the repair last year were not in the dive well only on the upper deck. In the concrete joint spaces, there is a 2 to 3 inches cap and whoever did the caulking years ago put backer rod to fill it in, and use self-leveling caulk, the caulk failed and the backer rod has fallen in and now there are 3" caps and it gets behind there, we're losing a whole seam and its draining water through that concrete slab. Brooks asked why this wasn't fixed last year, Renly stated that it looks like solid caulk. Hurlley asked how it was found this year, our staff started tapping on the caulk joint and they found some hollow spots and found the one big hole. Brooks asked about time for this repair, Renly stated cost is about \$1,500, it would take about 3-4 days to get the materials and a week or two if we were to do this in house.

Badger Pool stated that it should hold through the season. Hurley asked what is happening underneath the pool with all the water leaking. Renly stated that there are several leaks and it's almost impossible to know exactly what is happening or where the water is going. Hurley stated that he is concerned about filling the pool and having it collapse. Brooks asked Bubolz if there is some equipment that we can use to see if there are cavities under the pool. Bubolz stated that is some equipment can be used to determine if it's hollow underneath. There are several companies that can do this. We have also seen a problem with plumbing at other Municipalities, they have the same issues with aging pools. Renly stated that we did check the drain and there was nothing showing a problem with the pipes. Bubolz stated that he could reach out to some of the companies that have the equipment that has the capability to look for the hollow spots. Brooks asked if we wanted to wait for more information. Hurley stated that it is going to cost to have a company to come in to look for the hollow spot, and we have a budget to stay working within. Lewis stated that he has gotten a lot of letters from residents that want to use the pool. Sergeant asked Renly if we will have to grind down to the concrete. Renly stated just where the seams are, Sergeant asked if this would be every seam in the pool, Renly stated just the seams in the dive well. Brooks summarized that we would be spending \$2000 + labor to see if it works while we wait to see if there is a cavity under the pool. Renly will order the supplies and get staff scheduled.

**b. Emergency Action Plan Addition - Load Shedding (Placeholder)**

Nothing new to report.



**c. Water Rate Case**

No discussion

**d. AMI Project (Placeholder)**

Letters went and we received 2 call backs to make appointments. Renly thinks we need to just send out the rest of the letters, so we can get as many done as we can, we will be changing the letter to make it more urgent as time goes on. Brooks stated the he was in contact with Phil Hanson from WPPI, they are wrapping up a Northstar conversion at one utility and finishing the final stages at other, we had asked them to get in touch with us mid-year about scheduling our Northstar conversion at the end of year into first part of 2022, Phil proposed a time line of being in our offices in early September getting data and things set up, then the WPPI team will go away for about 90 days. Sometime in January they will come back and work with our billing team on the conversion to Northstar. For the month of January there will be dual processing, we would be billing in house and WPPI would also be processing billing. The upside is that this gets us on the calendar. It gives us a date to get the water meters changed out, 8 months down the road. Laddick stated that he likes that there will be a dual billing going on. He wanted to know how confident are we that we will get those 271 water meters in by then, the letters have gone out, we will be adjusting the letters to make it more urgent. Renly will reach out to Phil Hanson at WPPI to get us on the schedule.

**(1) Current AMI count remaining- Elec: 0 Water: 271**

**e. Lake Leota Dam Repair Update (Placeholder)**

Renly has been talking to Uriah from the DNR and Todd from Jewel & Assoc., that the historic committee about the concerns about the gabion basket wall of the spillway, the committee would like to see something done where it is not just a concrete wall. We are looking to have a tentative meeting time of the 2<sup>nd</sup> week of June with Renly, Uriah, Todd and Dan from HPC on site to discussed options. Renly had talked to Todd and Uriah, their initial take is that it needs to be concrete with nothing in front of it. They would be open to stamping and adding color it to make it look like stone, we are going to talk about these options.

Renly found out today that FEMA is going to be doing some inspections on the dam, Renly will be filling out paperwork. Brooks asked if Renly and Jason are keeping tracking the cost as it changes up and down. Renly stated that we have \$80,000 from DNR and we have \$150,000 budgeted. FEMA is only going through our process with the dam and making sure that we have everything in order. This has nothing to do with the work that were doing with the dam. Todd told Renly that he estimates that the stamping and coloring will cost \$9000-\$15,000 additional. Currently we have \$203,000 for total cost of repairs. Renly said that we do have some wiggle room, approximately \$25,000 for any unexpected repairs needed. This would take all of the additional funds for the unknown. If anything comes up, we will have to repair it. Brooks asked if the American Rescue Plan would have any additional funds from Storm water that we can use on this project. Renly knows the Storm water was included, but he didn't know if there were any limitations to it. Sergeant and Julie

Roberts sat in on a conference call about the ARP, they have draft rules, that are not finalized yet. Sergeant said from what he took away from the call that we would not receive any money this year, and he didn't feel the dam project would qualify, but it could help with other projects. That could free up money for the dam project later. When the rules are finalized, council will need to prioritize where money needs to go to within the next year.

**f. West Side Park Progress (Placeholder)**

Council approved the contract for the RFP.

Renly discussed with Roger Hunt about his use of the field next to the cemetery for hay, he can use it this year but the City will need to use it the following 2 years for soccer fields, Hunt didn't have any issues with that, the hay field was getting sparse and he was going to have to replant it anyway. Hunt asked if he could come back in 2 years to replant it, requested that if the City had any other land that had hay on if we would let him take the hay off of it, Renly didn't know of any at this time.

**g. Municipal Services building expansion progress report.**

Renly had a couple changes, from the state inspector, because of the type of use of the building that we had. Page 15, first change was just across where the bathrooms are, extending the fire wall across span by the bathroom, and add an additional fire wall between the storage bay and the mechanic's bay. This is going to add to the cost, Sketchworks and 1848 are working on getting a cost on misc. materials back to us, it is still expected to be under our million-dollar budget. The other one was on page 19 of the plans, the southernmost side of building we had to add windows. Brooks asked the project was going to start, Renly stated that we are working on the contract now, it will need to go to Mark Kopp to look at and then to council for final approval.

**h. Dog Park Fence Update**

Renly, because of the last update quote was beyond 30 days we had to go back and get an update cost on materials and it has gone up it will be additional 1,300 more. Renly has an onsite meeting with Segar now that we have approval to go ahead with the project, either this week or next, Segar will order materials once the site review is done. Segar, is booked out until July, Renly thinks it should be done by Mid-August.

**i. Skylift Discussion**

The price for the Skylift is a \$191,000, Renly thinks we have 135,000 - \$140,000 budgeted for this, we are \$60,000 short, company is willing to let us pay the \$60,000 in the next fiscal year. Hurley asked if we ever got an answer on why they didn't honor the contract of the bid. Brooks stated that it wasn't a contract, it was an estimate. Renly said that it was just an estimate for budgeting purposes, and Mark Kopp looked at and agreed. Discussion as to whether we hold off until 2022 or move something else to the next year. It was brought up about not buying a new truck this year. Renly stated that the truck was budgeted for \$47,000 for this year. Hurley stated that the truck is the likely choice to take off. Lewis stated that we should buy the Skylift and put off buying the new truck, Hurley and Ladick are for buying the

Skylift and push the truck out. Renly to move forward on the Skylift. Renly, Sergeant and Julie will sit down and discuss the numbers.

**j. Evansville W&L Customer Appreciation Event – Sept 10<sup>th</sup>**

Renly stated we have it scheduled on September 10<sup>th</sup>. MEUW is coming with training trailer, which is like the smaller model we had last year. Also Renew Wisconsin is going to put on an EV ride and drive 6-12 EV's that people can either ride or drive. Working with Focus on Energy for a booth, Kona Ice is coming back for the slushies', also brats, and give-a-ways. Renew Wisconsin will be advertising for us too. Hoping for a good show this year.

**9. City Engineer Report**

**a. Sub-division / Development Update**

Brian has a meeting with Dave Olsen, off of Porter Rd. also trying to get a hold of the developer on the Fox side to coordinate, did receive a draft development yesterday for the Dave Olsen side and that is being reviewed.

**b. Inflow and Infiltration Study (Placeholder)**

Waiting on a more severe storm to test out, the storm we just had was not severe enough.

**c. Roadway construction & other project updates. (Placeholder)**

- **First & Second St Projects**

Major water outage, underground pipe and main that no one knew about, water is back on. They have completed the sanitary sewer on Second St from Highland all the way to Old Hwy 92, they going to start the water main on that same stretch, but they are having difficulty getting pipe delivered. We are not the only ones, we are seeing or hearing problems from others on getting pipe delivered as well. We are in discussions with the contractor to jump over to First St, and start installing sanitary sewer. Will have more details after Memorial Day.

- **Sidewalks**

No Action at this time

- **Discussion and possible motion regarding assessments and utility connections for annexed properties.**

Bulbolz stated that he has had some discussion with the property owners at the end of Second St where the City is re-constructing the street utilities. A few parties are interested in annexing into the City. The main questions are regarding the fees, and if they could be added to the assessment so they didn't have to pay a lump sum. There have been questions from 2 parties so far. One was about just hooking up to water for the needs of watering, they would not need the sewer for the time being. The other was about getting water only to wash their dump truck but will not need the sewer. They are working being annexed if they don't meet

the timeline, for the project to be finished, were they are not done in time for it to go on the property tax bill for the 10 year assessment policy, or can they added later and still get the 10 year assessment policy. Sergeant stated that it is to the resident's advantage to annex now while the city is doing the work. Brooks stated that it is to our advantage while the city is doing the work now, otherwise we will have to open the road now. Sergeant stated the project includes the stubbing out of the water and sewer to behind the sidewalk, if they want to connect they just have to dig up their property to hook up so that wouldn't be an issue. Bulbolz was asked to clarify if the stubs being put are being held as a future assessment on that property. Bulbolz stated that it is not. The City will offer this one time incentive to finance the hookup fees by the time the project is done, after that they will have to pay the lump sum. All agreed.

Can we hook up water without sewer, Hammett stated that we have several properties that have water only, no sewer, these are properties that have been long established, and there are no new properties. Sergeant stated that if they annexed in and just wanted water, he is betting that would be possible.

### **Administrative Staff's Report**

- **Non-Collectable Utility Accounts Review (Placeholder)**  
No Changes at this time, there are 4 unoccupied properties disconnected. Sent Crew out with 59 residential and 5 commercial door knockers, Brooks commented that was down from last month, Hammett agreed and stated that it was busy this afternoon, so hoping the number will be even less.
  
- **Motion to recommend the approval of the Settler's Grove Subdivision plat.**  
Motion to approve the Settler's Grove Subdivision Plat: Brooks, second Ladick  
  
Sergeant stated the he doesn't see record that this has been brought before the committee before, Brooks stated they had not seen the plat. This plat was approved by Planning Commission, we have gone over this with department and staff, preliminary approval by Planning Commission subject to a bunch of conditions, that being construction drawings for final approve, and Sergeant wanted MSC to get a look at it. Brooks asked Renly if the easements look good for utilities, Renly looked at it, he only had one question, are the outlets for the bike path going to be private or city. Sergeant stated that they are going to be City.  
  
Motion to approve recommend approval: Motion approved 3-0

## **10. WPPI**

- a. Amy Wanek – ESR Report  
Evansville Water & Light received first place for the MEUW Safety Award, 15,000 plus hours of worker exposer, and also first place in its category for the APPA Safety Award. We did put out a press release for one of them and are thinking about doing

another one. Brooks sent out the press release for RP3 too. Hurtley would like another one out there.

We have one new residential solar system that was installed during the month and one that was submitted for approval. The solar companies are still going around, and residents are taking advantage of the no money down.

Scholarship night is May 26, 2021, Wanek will be presenting the award to one high school student, and the scholarship is \$1,000. We handed out some coloring contest winner prizes for Rock n' Rollz. The Green Team at EHS didn't win the PSC Energy Innovation Award, Wanek has been in contact with the leader of the team giving them ideas to see how she can help and get students more interested.

Lastly, Wanek got an old report of the High School's HVAC system which is geothermal, that had been saying that this isn't working, the report is 10 years old and we don't know what has been done between then and now. There are some control issues, that won't let the geothermal system do its job. Currently the boiler controls are set up before the geothermal can turn on. Wanek needs to get with a buildings and grounds person to see what has been happening since the report.

Brooks stated that there are two bills at the capitol circulating for finance for 3<sup>rd</sup> party solar, a very real concern. We are working on a response to this bill, they would effectively deregulate electric production in Wisconsin and change the definition of what a utility is, so any one can come into the state and sell solar to residence and avoid regulation of the utility and have access to the grid unfettered. One of the 2 bills said the rates to the utilities would be required to pay for the excess energy. They would have to be robust enough to promote devolvement of new solar systems. We would be required to not pay retail to those roof top systems, but pay a subsidized rate and take energy for our system. WPPI, MEUW, the CO-OP association sprang into actions, and labor trades saw that many of these systems will be built with non-union out of state labor and they organized as well. They want to make the point that solar is here to stay, that utility scale solar is the best way to provide safe and reliable renewable energy. It looks as if both of those bills are going to die before they go to the floor.

Renly talked to the Evansville Ford Dealer, the dealer group is looking to become an EV Certified Deal, at the cost of \$50,000 per dealer, to meet the requirements to sell EV's. Renly let them know about our incentives for the charging stations, they are required to put it three level 3 charging stations at their dealer, 1 inside and 2 outside. Renly will be forwarding Amy's contact information when they decide to move forward. Brooks asked what the other dealerships, WPPI is in 51 communities, might be room for a broader partnership, Renly can reach out and see what other dealerships are in their group. Wanek stated that the incentive has a cap of \$5000, for the level 3 station at the Chevy dealer it was 1500 for each charger. Brooks asked about our public charging station, if it is being used, it averages between 5 and 15 users a month.

## **11. Old Business**

- **Youth Center Update.**

Renly had a meeting with Becky and Susan to go over some things, as well as Julie at AWARE about the air handler, Julie contacted the AWARE director and

they are willing to cover the cost of their own unit. She asked if we could purchase it when we purchase ours and they would reimburse us for it.

- **Flooring** –Looking at a couple of options, RE grid rubber flooring as well as vinyl as well as indoor/outdoor floor. Looking at having HVAC Company come in to look at the duct work, there is a bump out in the floor that needs to be removed and redo some of the duct work there putting in some walk across floor vents. Once the carpet and stuff is ripped out and see what kind of flooring it is and what condition it is in. We can see what we are going to put down and who we are going to have do the work.
- **Air Purifiers**-No discussion
- **Holiday Lights**

The committee has looked into 2 possible choices, one from each supplier, we are waiting for samples to come and then we will meet again. Estimates were between \$14,000 & \$18,000. We need to find out where the money is coming from. We don't have to pay until the end of the year.

Brooks also mentioned that the downtown flowers should be going up Saturday morning.

## 12. New Business

- **Chloride Reduction Program**

Renly said that Cory called to ask a question about water softener replacements. He has an old timer water softener and would like to replace it with a water based high efficacy water softener and was wondering if he purchases it and removed the old one and installed the new one himself would we still reimburse him. Hurtley said he could take a picture of the old one and the new and provide a receipt that should work. Sergeant stated that he would need a permit to install and will need it inspected, as long as they have the building permit, it shouldn't matter who installs it.

Brooks didn't know who has been tasked with keeping the website updated, but we have these incentives for water softeners and other programs, we should be promoting them. Renly stated that once Marisa is back he is going to have as part of her job duties, update the website and Facebook for these kind of things.
- **Discussion regarding the cemetery columbarium.**

Hurtley brought up for discussion the possible purchase of another Columbarium. When we purchase the one we have now we ordered it with ½ single niches and ½ double niches, we have sold all the doubles and have only sold 2 singles. We have ordered 5 more double doors, and can make 5 more double niches. For the future though we need to think about getting another one with all double niches, the cost is \$29,000 which is close to what we paid for the one we have now, which has paid for itself. Brooks asked if the cemetery has its own budget and maybe we need to look at rates again soon. Ladick agreed that we should order another one with double niches only. Hurley stated that we can look at next year's budget.

## 13. Upcoming Meeting Date, June 29<sup>th</sup>, 2021 at 5:00 pm

#### **14. Adjourn**

Motion to Adjourn Brooks, Ladick second Adjourn at 6:50pm.

James Brooks, Committee Chair

*Please turn off all cell phones and electronic devices before meeting commences. If you have any special accessibility issues, please contact Evansville City Hall at 608-882-2266 prior to the scheduled meeting. Thank you.*

## NOTICE

**Municipal Services Committee**  
Special Meeting  
Tuesday June 1st, 2021 at 6:00 pm

Due to social distancing guidelines this meeting will be conducted via web conference at: [meet.google.com/wje-xuct-mbr](https://meet.google.com/wje-xuct-mbr). The public may also use the teleconference option at +1 (315)-801-9407 then enter conference pin: 863 831 330#

### Minutes

**1. Call meeting to order**

Brooks called the meeting to order at 6:00 pm

**2. Roll call.**

In attendance was Committee Chair Jim Brooks, Gene Lewis and Ben Ladick, also present was Chad Renly.

**3. Civility Reminder**

**4. Motion to approve the agenda as presented.**

Ladick/Lewis Motion Passed 3-0

**5. Motion to recommend to Common Council the 2020 CMAR (Compliance Maintenance Annual Report)**

Ladick/Lewis Motion Passed 3-0

**6. Upcoming Meeting Date, June 29<sup>th</sup>, 2021 at 5:00 pm**

**7. Adjourn**

Brooks/Ladick at 6:03 pm

James Brooks, Committee Chair

*Please turn off all cell phones and electronic devices before meeting commences. If you have any special accessibility issues, please contact Evansville City Hall at 608-882-2266 prior to the scheduled meeting. Thank you.*



# AIA<sup>®</sup> Document A101<sup>®</sup> – 2017

## **Standard Form of Agreement Between Owner and Contractor where the basis of payment is a Stipulated Sum**

**AGREEMENT** made as of the Eighteenth day of May in the year Two Thousand Twenty-one  
(In words, indicate day, month and year.)

**BETWEEN** the Owner:  
(Name, legal status, address and other information)

City of Evansville, WI  
31 S. Madison Street  
PO Box 529  
Evansville, WI 53536

and the Contractor:  
(Name, legal status, address and other information)

1848 Construction, Inc.  
3302 Latham Drive  
Madison, WI 53713

for the following Project:  
(Name, location and detailed description)

Evansville Maintenance Garage  
15 Old Hwy 92  
Evansville, WI 53562

The Architect:  
(Name, legal status, address and other information)

Sketchworks Architecture, LLC  
7780 Elmwood Ave., Suite 208  
Middleton, WI 53562

The Owner and Contractor agree as follows.

### **ADDITIONS AND DELETIONS:**

The author of this document has added information needed for its completion. The author may also have revised the text of the original AIA standard form. An *Additions and Deletions Report* that notes added information as well as revisions to the standard form text is available from the author and should be reviewed. A vertical line in the left margin of this document indicates where the author has added necessary information and where the author has added to or deleted from the original AIA text.

This document has important legal consequences. Consultation with an attorney is encouraged with respect to its completion or modification.

The parties should complete A101<sup>®</sup>–2017, Exhibit A, Insurance and Bonds, contemporaneously with this Agreement. AIA Document A201<sup>®</sup>–2017, General Conditions of the Contract for Construction, is adopted in this document by reference. Do not use with other general conditions unless this document is modified.

Init.

## TABLE OF ARTICLES

- 1 THE CONTRACT DOCUMENTS
- 2 THE WORK OF THIS CONTRACT
- 3 DATE OF COMMENCEMENT AND SUBSTANTIAL COMPLETION
- 4 CONTRACT SUM
- 5 PAYMENTS
- 6 DISPUTE RESOLUTION
- 7 TERMINATION OR SUSPENSION
- 8 MISCELLANEOUS PROVISIONS
- 9 ENUMERATION OF CONTRACT DOCUMENTS

## EXHIBIT A INSURANCE AND BONDS

### ARTICLE 1 THE CONTRACT DOCUMENTS

The Contract Documents consist of this Agreement, Conditions of the Contract (General, Supplementary, and other Conditions), Drawings, Specifications, Addenda issued prior to execution of this Agreement, other documents listed in this Agreement, and Modifications issued after execution of this Agreement, all of which form the Contract, and are as fully a part of the Contract as if attached to this Agreement or repeated herein. The Contract represents the entire and integrated agreement between the parties hereto and supersedes prior negotiations, representations, or agreements, either written or oral. An enumeration of the Contract Documents, other than a Modification, appears in Article 9.

### ARTICLE 2 THE WORK OF THIS CONTRACT

The Contractor shall fully execute the Work described in the Contract Documents, except as specifically indicated in the Contract Documents to be the responsibility of others.

### ARTICLE 3 DATE OF COMMENCEMENT AND SUBSTANTIAL COMPLETION

§ 3.1 The date of commencement of the Work shall be:

*(Check one of the following boxes.)*

The date of this Agreement.

A date set forth in a notice to proceed issued by the Owner.

Established as follows:

*(Insert a date or a means to determine the date of commencement of the Work.)*

Three (3) working days from when the building permit and all other permits are required to begin, are available.

If a date of commencement of the Work is not selected, then the date of commencement shall be the date of this Agreement.

§ 3.2 The Contract Time shall be measured from the date of commencement of the Work.

#### § 3.3 Substantial Completion

§ 3.3.1 Subject to adjustments of the Contract Time as provided in the Contract Documents, the Contractor shall achieve Substantial Completion of the entire Work:

*(Check one of the following boxes and complete the necessary information.)*

AIA Document A101® – 2017. Copyright © 1915, 1918, 1925, 1937, 1951, 1958, 1961, 1963, 1967, 1974, 1977, 1987, 1991, 1997, 2007 and 2017 by The American Institute of Architects. All rights reserved. The "American Institute of Architects," "AIA," the AIA Logo, "A101," and "AIA Contract Documents" are registered trademarks and may not be used without permission. This document was produced by AIA software at 13:23:46 ET on 06/24/2021 under Order No.0514486010 which expires on 09/11/2021, is not for resale, is licensed for one-time use only, and may only be used in accordance with the AIA Contract Documents® Terms of Service. To report copyright violations, e-mail [copyright@aia.org](mailto:copyright@aia.org).

User Notes:

(792882787)



[ ] Not later than ( ) calendar days from the date of commencement of the Work.

[X] By the following date: June 30, 2022 based on the Date of Commencement being prior to June 15, 2021.

§ 3.3.2 Subject to adjustments of the Contract Time as provided in the Contract Documents, if portions of the Work are to be completed prior to Substantial Completion of the entire Work, the Contractor shall achieve Substantial Completion of such portions by the following dates:

Portion of Work	Substantial Completion Date
-----------------	-----------------------------

§ 3.3.3 If the Contractor fails to achieve Substantial Completion as provided in this Section 3.3, liquidated damages, if any, shall be assessed as set forth in Section 4.5.

#### ARTICLE 4 CONTRACT SUM

§ 4.1 The Owner shall pay the Contractor the Contract Sum in current funds for the Contractor's performance of the Contract. The Contract Sum shall be Nine Hundred Four Thousand Ninety Dollars and Zero Cents (\$ 904,090.00 ), subject to additions and deductions as provided in the Contract Documents.

#### § 4.2 Alternates

§ 4.2.1 Alternates, if any, included in the Contract Sum:

Item	Price
Alternate #2 Deduct Bridge Crane:	(-\$60,000.00)
Alternate #3 Schedule Flexibility:	\$951,890.00

§ 4.2.2 Subject to the conditions noted below, the following alternates may be accepted by the Owner following execution of this Agreement. Upon acceptance, the Owner shall issue a Modification to this Agreement. (Insert below each alternate and the conditions that must be met for the Owner to accept the alternate.)

Item	Price	Conditions for Acceptance
------	-------	---------------------------

§ 4.3 Allowances, if any, included in the Contract Sum:  
(Identify each allowance.)

Item	Price
Building Permit:	\$1,000.00
Asphalt Pavement:	\$9,700.00
Cold Weather Conditions and Protection:	\$1,500.00

§ 4.4 Unit prices, if any:

(Identify the item and state the unit price and quantity limitations, if any, to which the unit price will be applicable.)

Item	Units and Limitations	Price per Unit (\$0.00)
------	-----------------------	-------------------------

§ 4.5 Liquidated damages, if any:

(Insert terms and conditions for liquidated damages, if any.)

\$500.00 Per Day.

Init.

§ 4.6 Other:

*(Insert provisions for bonus or other incentives, if any, that might result in a change to the Contract Sum.)*

In the event of a significant price increase for material occurring during the performance of the contract through no fault of the contractor, the contract sum shall be equitably adjusted by change order in accordance with the procedures of the contract documents. A change in price of an item of material will be considered significant if the price of an item increases twenty percent (20%) or more between the date of the original bid and the date of purchase by the contractor. The amount of the increase contemplated herein shall be capped at the actual cost of the increase with no additional contractor or other fees being applied.

## ARTICLE 5 PAYMENTS

### § 5.1 Progress Payments

§ 5.1.1 Based upon Applications for Payment submitted to the Architect by the Contractor and Certificates for Payment issued by the Architect, the Owner shall make progress payments on account of the Contract Sum to the Contractor as provided below and elsewhere in the Contract Documents.

§ 5.1.2 The period covered by each Application for Payment shall be one calendar month ending on the last day of the month, or as follows:

§ 5.1.3 Provided that an Application for Payment is received by the Architect not later than the 5th day of a month, the Owner shall make payment of the amount certified to the Contractor not later than the 25th day of the same month. If an Application for Payment is received by the Architect after the application date fixed above, payment of the amount certified shall be made by the Owner not later than twenty ( 20 ) days after the Architect receives the Application for Payment.

*(Federal, state or local laws may require payment within a certain period of time.)*

§ 5.1.4 Each Application for Payment shall be based on the most recent schedule of values submitted by the Contractor in accordance with the Contract Documents. The schedule of values shall allocate the entire Contract Sum among the various portions of the Work. The schedule of values shall be prepared in such form, and supported by such data to substantiate its accuracy, as the Architect may require. This schedule of values shall be used as a basis for reviewing the Contractor's Applications for Payment.

§ 5.1.5 Applications for Payment shall show the percentage of completion of each portion of the Work as of the end of the period covered by the Application for Payment.

§ 5.1.6 In accordance with AIA Document A201™-2017, General Conditions of the Contract for Construction, and subject to other provisions of the Contract Documents, the amount of each progress payment shall be computed as follows:

§ 5.1.6.1 The amount of each progress payment shall first include:

- .1 That portion of the Contract Sum properly allocable to completed Work;
- .2 That portion of the Contract Sum properly allocable to materials and equipment delivered and suitably stored at the site for subsequent incorporation in the completed construction, or, if approved in advance by the Owner, suitably stored off the site at a location agreed upon in writing; and
- .3 That portion of Construction Change Directives that the Architect determines, in the Architect's professional judgment, to be reasonably justified.

§ 5.1.6.2 The amount of each progress payment shall then be reduced by:

- .1 The aggregate of any amounts previously paid by the Owner;
- .2 The amount, if any, for Work that remains uncorrected and for which the Architect has previously withheld a Certificate for Payment as provided in Article 9 of AIA Document A201-2017;
- .3 Any amount for which the Contractor does not intend to pay a Subcontractor or material supplier, unless the Work has been performed by others the Contractor intends to pay;

Init.



- .4 For Work performed or defects discovered since the last payment application, any amount for which the Architect may withhold payment, or nullify a Certificate of Payment in whole or in part, as provided in Article 9 of AIA Document A201–2017; and
- .5 Retainage withheld pursuant to Section 5.1.7.

#### § 5.1.7 Retainage

§ 5.1.7.1 For each progress payment made prior to Substantial Completion of the Work, the Owner may withhold the following amount, as retainage, from the payment otherwise due:

*(Insert a percentage or amount to be withheld as retainage from each Application for Payment. The amount of retainage may be limited by governing law.)*

Zero Percent (0%)

§ 5.1.7.1.1 The following items are not subject to retainage:

*(Insert any items not subject to the withholding of retainage, such as general conditions, insurance, etc.)*

§ 5.1.7.2 Reduction or limitation of retainage, if any, shall be as follows:

*(If the retainage established in Section 5.1.7.1 is to be modified prior to Substantial Completion of the entire Work, including modifications for Substantial Completion of portions of the Work as provided in Section 3.3.2, insert provisions for such modifications.)*

§ 5.1.7.3 Except as set forth in this Section 5.1.7.3, upon Substantial Completion of the Work, the Contractor may submit an Application for Payment that includes the retainage withheld from prior Applications for Payment pursuant to this Section 5.1.7. The Application for Payment submitted at Substantial Completion shall not include retainage as follows:

*(Insert any other conditions for release of retainage upon Substantial Completion.)*

§ 5.1.8 If final completion of the Work is materially delayed through no fault of the Contractor, the Owner shall pay the Contractor any additional amounts in accordance with Article 9 of AIA Document A201–2017.

§ 5.1.9 Except with the Owner's prior approval, the Contractor shall not make advance payments to suppliers for materials or equipment which have not been delivered and stored at the site.

#### § 5.2 Final Payment

§ 5.2.1 Final payment, constituting the entire unpaid balance of the Contract Sum, shall be made by the Owner to the Contractor when

- .1 the Contractor has fully performed the Contract except for the Contractor's responsibility to correct Work as provided in Article 12 of AIA Document A201–2017, and to satisfy other requirements, if any, which extend beyond final payment; and
- .2 a final Certificate for Payment has been issued by the Architect.

§ 5.2.2 The Owner's final payment to the Contractor shall be made no later than 30 days after the issuance of the Architect's final Certificate for Payment, or as follows:

#### § 5.3 Interest

Payments due and unpaid under the Contract shall bear interest from the date payment is due at the rate stated below, or in the absence thereof, at the legal rate prevailing from time to time at the place where the Project is located.

*(Insert rate of interest agreed upon, if any.)*

Init.

(12) % Per Annum

## ARTICLE 6 DISPUTE RESOLUTION

### § 6.1 Initial Decision Maker

The Architect will serve as the Initial Decision Maker pursuant to Article 15 of AIA Document A201–2017, unless the parties appoint below another individual, not a party to this Agreement, to serve as the Initial Decision Maker.  
*(If the parties mutually agree, insert the name, address and other contact information of the Initial Decision Maker, if other than the Architect.)*

### § 6.2 Binding Dispute Resolution

For any Claim subject to, but not resolved by, mediation pursuant to Article 15 of AIA Document A201–2017, the method of binding dispute resolution shall be as follows:  
*(Check the appropriate box.)*

- [ X ] Arbitration pursuant to Section 15.4 of AIA Document A201–2017
- [ ] Litigation in a court of competent jurisdiction
- [ ] Other *(Specify)*

If the Owner and Contractor do not select a method of binding dispute resolution, or do not subsequently agree in writing to a binding dispute resolution method other than litigation, Claims will be resolved by litigation in a court of competent jurisdiction.

## ARTICLE 7 TERMINATION OR SUSPENSION

§ 7.1 The Contract may be terminated by the Owner or the Contractor as provided in Article 14 of AIA Document A201–2017.

§ 7.1.1 If the Contract is terminated for the Owner's convenience in accordance with Article 14 of AIA Document A201–2017, then the Owner shall pay the Contractor a termination fee as follows:  
*(Insert the amount of, or method for determining, the fee, if any, payable to the Contractor following a termination for the Owner's convenience.)*

§ 7.2 The Work may be suspended by the Owner as provided in Article 14 of AIA Document A201–2017.

## ARTICLE 8 MISCELLANEOUS PROVISIONS

§ 8.1 Where reference is made in this Agreement to a provision of AIA Document A201–2017 or another Contract Document, the reference refers to that provision as amended or supplemented by other provisions of the Contract Documents.

§ 8.2 The Owner's representative:  
*(Name, address, email address, and other information)*

Chad Renly, Municipal Services Director  
City of Evansville, WI  
535 S. Madison Street  
Evansville, WI 53536  
chad.renly@ci.evansville.wi.gov  
608-490-1313

Init.

AIA Document A101® – 2017. Copyright © 1915, 1918, 1925, 1937, 1951, 1958, 1961, 1963, 1967, 1974, 1977, 1987, 1991, 1997, 2007 and 2017 by The American Institute of Architects. All rights reserved. The "American Institute of Architects," "AIA," the AIA Logo, "A101," and "AIA Contract Documents" are registered trademarks and may not be used without permission. This document was produced by AIA software at 13:23:46 ET on 06/24/2021 under Order No.0514486010 which expires on 09/11/2021, is not for resale, is licensed for one-time use only, and may only be used in accordance with the AIA Contract Documents® Terms of Service. To report copyright violations, e-mail [copyright@aia.org](mailto:copyright@aia.org).  
User Notes:

(792882787)



§ 8.3 The Contractor's representative:  
(Name, address, email address, and other information)

Brad Crowley, President/CEO  
1848 Construction, Inc.  
3302 Latham Drive  
Madison, WI 53713  
bcrowley@1848construction.com  
608-833-1848

§ 8.4 Neither the Owner's nor the Contractor's representative shall be changed without ten days' prior notice to the other party.

**§ 8.5 Insurance and Bonds**

§ 8.5.1 The Owner and the Contractor shall purchase and maintain insurance as set forth in AIA Document A101™-2017, Standard Form of Agreement Between Owner and Contractor where the basis of payment is a Stipulated Sum, Exhibit A, Insurance and Bonds, and elsewhere in the Contract Documents.

Exhibit A – Insurance Dated 05-18-2021  
Payment and performance bond not included.

§ 8.5.2 The Contractor shall provide bonds as set forth in AIA Document A101™-2017 Exhibit A, and elsewhere in the Contract Documents.

§ 8.6 Notice in electronic format, pursuant to Article 1 of AIA Document A201-2017, may be given in accordance with AIA Document E203™-2013, Building Information Modeling and Digital Data Exhibit, if completed, or as otherwise set forth below:  
(If other than in accordance with AIA Document E203-2013, insert requirements for delivering notice in electronic format such as name, title, and email address of the recipient and whether and how the system will be required to generate a read receipt for the transmission.)

§ 8.7 Other provisions:

Exhibit B – Other Provisions Dated 05-18-2021

**ARTICLE 9 ENUMERATION OF CONTRACT DOCUMENTS**

§ 9.1 This Agreement is comprised of the following documents:

- .1 AIA Document A101™-2017, Standard Form of Agreement Between Owner and Contractor
- .2 AIA Document A101™-2017, Exhibit A, Insurance and Bonds
- .3 AIA Document A201™-2017, General Conditions of the Contract for Construction
- .4 AIA Document E203™-2013, Building Information Modeling and Digital Data Exhibit, dated as indicated below:  
(Insert the date of the E203-2013 incorporated into this Agreement.)

- .5 Drawings

Number	Title	Date
Sketchworks	For Construction	2021-03-19

- .6 Specifications

Section	Title	Date	Pages
Sketchworks	Bidding Documents and Technical Specifications	2021-03-19	(289)

.7 Addenda, if any:

Number	Date	Pages
Addendum #1	2021-04-15	(46)

Portions of Addenda relating to bidding or proposal requirements are not part of the Contract Documents unless the bidding or proposal requirements are also enumerated in this Article 9.

.8 Other Exhibits:

*(Check all boxes that apply and include appropriate information identifying the exhibit where required.)*

AIA Document E204™-2017, Sustainable Projects Exhibit, dated as indicated below:  
*(Insert the date of the E204-2017 incorporated into this Agreement.)*

The Sustainability Plan:

Title	Date	Pages
-------	------	-------

Supplementary and other Conditions of the Contract:

Document	Title	Date	Pages
----------	-------	------	-------

.9 Other documents, if any, listed below:

*(List here any additional documents that are intended to form part of the Contract Documents. AIA Document A201™-2017 provides that the advertisement or invitation to bid, Instructions to Bidders, sample forms, the Contractor's bid or proposal, portions of Addenda relating to bidding or proposal requirements, and other information furnished by the Owner in anticipation of receiving bids or proposals, are not part of the Contract Documents unless enumerated in this Agreement. Any such documents should be listed here only if intended to be part of the Contract Documents.)*

This Agreement entered into as of the day and year first written above.

\_\_\_\_\_  
OWNER (Signature)

Chad Renly, Municipal Services Director  
\_\_\_\_\_  
(Printed name and title)

\_\_\_\_\_  
CONTRACTOR (Signature)

Brad Crowley, President/CEO  
\_\_\_\_\_  
(Printed name and title)



# Additions and Deletions Report for AIA® Document A101® – 2017

This Additions and Deletions Report, as defined on page 1 of the associated document, reproduces below all text the author has added to the standard form AIA document in order to complete it, as well as any text the author may have added to or deleted from the original AIA text. Added text is shown underlined. Deleted text is indicated with a horizontal line through the original AIA text.

Note: This Additions and Deletions Report is provided for information purposes only and is not incorporated into or constitute any part of the associated AIA document. This Additions and Deletions Report and its associated document were generated simultaneously by AIA software at 13:23:46 ET on 06/24/2021.

PAGE 1

AGREEMENT made as of the Eighteenth day of May in the year Two Thousand Twenty-one

...

City of Evansville, WI  
31 S. Madison Street  
PO Box 529  
Evansville, WI 53536

...

1848 Construction, Inc.  
3302 Latham Drive  
Madison, WI 53713

...

Evansville Maintenance Garage  
15 Old Hwy 92  
Evansville, WI 53562

...

Sketchworks Architecture, LLC  
7780 Elmwood Ave., Suite 208  
Middleton, WI 53562

PAGE 2

Established as follows:

...

Three (3) working days from when the building permit and all other permits are required to begin, are available.

PAGE 3

By the following date: June 30, 2022 based on the Date of Commencement being prior to June 15, 2021.

...

§ 4.1 The Owner shall pay the Contractor the Contract Sum in current funds for the Contractor's performance of the Contract. The Contract Sum shall be Nine Hundred Four Thousand Ninety Dollars and Zero Cents (\$ 904,090.00 ), subject to additions and deductions as provided in the Contract Documents.

...

<u>Alternate #2 Deduct Bridge Crane:</u>	<u>(-\$60,000.00)</u>
<u>Alternate #3 Schedule Flexibility:</u>	<u>\$951,890.00</u>

...

<u>Building Permit:</u>	<u>\$1,000.00</u>
<u>Asphalt Pavement:</u>	<u>\$9,700.00</u>
<u>Cold Weather Conditions and Protection:</u>	<u>\$1,500.00</u>

...

\$500.00 Per Day.

#### PAGE 4

In the event of a significant price increase for material occurring during the performance of the contract through no fault of the contractor, the contract sum shall be equitably adjusted by change order in accordance with the procedures of the contract documents. A change in price of an item of material will be considered significant if the price of an item increases twenty percent (20%) or more between the date of the original bid and the date of purchase by the contractor. The amount of the increase contemplated herein shall be capped at the actual cost of the increase with no additional contractor or other fees being applied.

...

§ 5.1.3 Provided that an Application for Payment is received by the Architect not later than the 5th day of a month, the Owner shall make payment of the amount certified to the Contractor not later than the 25th day of the same month. If an Application for Payment is received by the Architect after the application date fixed above, payment of the amount certified shall be made by the Owner not later than twenty ( 20 ) days after the Architect receives the Application for Payment.

#### PAGE 5

Zero Percent (0%)

#### PAGE 6

(12) % Per Annum

...

Arbitration pursuant to Section 15.4 of AIA Document A201-2017

...

Chad Renly, Municipal Services Director  
City of Evansville, WI  
535 S. Madison Street  
Evansville, WI 53536  
chad.renly@ci.evansville.wi.gov  
608-490-1313

#### PAGE 7

**Additions and Deletions Report for AIA Document A101® - 2017.** Copyright © 1915, 1918, 1925, 1937, 1951, 1958, 1961, 1963, 1967, 1974, 1977, 1987, 1991, 1997, 2007 and 2017 by The American Institute of Architects. All rights reserved. The "American Institute of Architects," "AIA," the AIA Logo, "A101," and "AIA Contract Documents" are registered trademarks and may not be used without permission. This document was produced by AIA software at 13:23:46 ET on 06/24/2021 under Order No.0514486010 which expires on 09/11/2021, is not for resale, is licensed for one-time use only, and may only be used in accordance with the AIA Contract Documents® Terms of Service. To report copyright violations, e-mail [copyright@aia.org](mailto:copyright@aia.org).

User Notes:

(792882787)

Brad Crowley, President/CEO  
1848 Construction, Inc.  
3302 Latham Drive  
Madison, WI 53713  
bcrowley@1848construction.com  
608-833-1848

...

Exhibit A – Insurance Dated 05-18-2021  
Payment and performance bond not included.

...

Exhibit B – Other Provisions Dated 05-18-2021

...

<u>PAGE 8</u>	<u>Sketchworks</u>	<u>For Construction</u>	<u>2021-03-19</u>	
	<u>Sketchworks</u>	<u>Bidding Documents and Technical Specifications</u>	<u>2021-03-19</u>	<u>(289)</u>
...				
	<u>Addendum #1</u>	<u>2021-04-15</u>		<u>(46)</u>
...				

Chad Renly, Municipal Services Director

Brad Crowley, President/CEO



## **Certification of Document's Authenticity**

**AIA® Document D401™ – 2003**

I, Brad M. Crowley, hereby certify, to the best of my knowledge, information and belief, that I created the attached final document simultaneously with its associated Additions and Deletions Report and this certification at 13:23:46 ET on 06/24/2021 under Order No. 0514486010 from AIA Contract Documents software and that in preparing the attached final document I made no changes to the original text of AIA® Document A101™ – 2017, Standard Form of Agreement Between Owner and Contractor where the basis of payment is a Stipulated Sum, as published by the AIA in its software, other than those additions and deletions shown in the associated Additions and Deletions Report.

---

*(Signed)*

---

*(Title)*

---

*(Dated)*



# CITY OF EVANSVILLE

## 15 OLD HWY 92 EVANSVILLE, WI

### PROJECT DATA

LOCATION:  
535 S MADISON ST  
EVANSVILLE, WI 53536

REGULATING MUNICIPALITIES:  
CITY OF EVANSVILLE  
ROCK COUNTY  
STATE OF WISCONSIN

BUILDING CODE:  
CITY OF EVANSVILLE ZONING ORDINANCES  
ROCK COUNTY ZONING ORDINANCES  
WISCONSIN ADMINISTRATIVE CODE  
2015 INTERNATIONAL BUILDING CODE  
ACCESSIBILITY ANSI A117.1 - 2009

PROJECT DESCRIPTION:  
NEW BUILDING ADDITION CONSISTING OF:  
1 STORY OF S1 OCCUPANCY

OCCUPANCY TYPE:  
PRIMARY: S1

CONSTRUCTION TYPE:  
IIB

ALLOWABLE BUILDING AREA & HEIGHT:  
(IBC TABLE 504.3)  
MAXIMUM HEIGHT ABOVE GRADE PLANE = 55 FEET  
MAXIMUM STORIES ALLOWED = 2 STORIES  
(IBC TABLE 504.4)  
MAXIMUM AREA ALLOWED PER FLOOR = 17,500 SF  
(IBC TABLE 506.2)  
AREA MODIFICATIONS (IBC SECTION 506)  
TOTAL MAXIMUM ALLOWABLE AREA PER FLOOR = 23,800 SF

ACTUAL BUILDING AREA & HEIGHT:  
HEIGHT ABOVE GRADE PLANE = 22'-8" FEET  
STORIES = 1 STORY  
TOTAL BUILDING AREA = 21,600 SF

AREA:  
EXISTING BUILDING AREA = 12,000 SF  
TOTAL AREA OF FLOOR WORK IS TO OCCUR = 9,600 SF  
TOTAL BUILDING AREA = 21,600

NUMBER OF TOTAL BUILDING OCCUPANTS (TABLE 1004.1.2):  
S-1 OCCUPANCY = 21,600 SF / 300 GROSS = 72 OCC

#### PLUMBING:

EXISTING PLUMBING FIXTURES IN EXISTING BUILDING TO REMAIN. WITHIN 500' OF MAINTENANCE BUILDING

**WATER CLOSETS**  
MEN @ 1 / 100 = 1  
WOMEN @ 1 / 100 = 1  
TOTAL REQUIRED = 2  
TOTAL PROVIDED = 2

**LAVATORIES**  
MEN @ 1 / 100 = 1  
WOMEN @ 1 / 100 = 1  
TOTAL REQUIRED = 2  
TOTAL PROVIDED = 2

**SERVICE SINK**  
1 REQUIRED = 1 PROVIDED

**DRINKING FOUNTAIN**  
1 REQUIRED = 1 BILEVEL PROVIDED

ALL FIXTURES TO COMPLY WITH ICC A117.1

**FIRE CONTROL:**  
NON SPRINKLERED BUILDING  
3- HOUR FIRE BARRIER AT ADDITION TO SEPARATE FIRE AREAS (707.3.10)  
PORTABLE FIRE EXTINGUISHERS (IBC SECTION 906.3.1)  
HAZARD TYPE = MOD  
MAXIMUM DISTANCE = 75 FEET  
NUMBER REQUIRED = 2

**EXITS:**  
COMMON PATH OF EGRESS TRAVEL- 75 FEET  
EXIT ACCESS DISTANCE- 200 FEET  
EXIT(S) REQUIRED TO MEET EXITING DISTANCES = 2  
EXIT(S) PROVIDED TO MEET DISTANCES = 2  
MIN 60% OF PUBLIC EXTERIOR DOORS TO BE ON ACCESSIBLE ROUTE

**ACCESSIBILITY:**  
FOLLOW IBC 2015 AND ANSI 117.1 (2009)

### PROJECT GENERAL NOTES:

- CONTRACTOR SHALL NOTIFY ARCHITECT IMMEDIATELY UPON DISCOVERING ANY DISCREPANCIES OR CONFLICTING INFORMATION IN THESE DOCUMENTS. CONTRACTOR SHALL CAREFULLY REVIEW AND COMPARE ALL DRAWINGS DURING THE BIDDING PERIOD AND BEFORE INSTALLATION OF THEIR WORK. ANY INCONSISTENCIES IN THE DRAWINGS SHALL BE REPORTED PROMPTLY TO THE ARCHITECT AND ENGINEER(S) FOR CLARIFICATION.
- DO NOT SCALE DRAWINGS. THE DRAWINGS ARE NOT NECESSARILY TO SCALE - USE GIVEN DIMENSIONS. DIMENSIONS TAKE PRECEDENCE OVER SCALE. CONTRACTOR TO VERIFY ALL DIMENSIONS IN FIELD.
- CONTRACTOR SHALL NOTIFY ARCHITECT AND OWNER IMMEDIATELY UPON DISCOVERING ANY UNANTICIPATED EXISTING SITE CONDITIONS AFFECTING THE EXECUTION OF THESE DOCUMENTS (SUCH AS HAZARDOUS MATERIALS, ETC.).
- CONTRACTOR SHALL ABIDE BY ALL LOCAL, STATE AND FEDERAL CODES AND REGULATIONS GOVERNING THIS PROJECT.
- JOB SITE SHALL BE BROOM SWEEP AND CLEAN AT THE END OF EACH DAY. ALL DEBRIS SHALL BE PICKED UP AND DISPOSED OF PROPERLY INTO APPROVED CONTAINER.
- MAINTAIN DESIGNATED EGRESS ROUTES DURING CONSTRUCTION BY KEEPING CLEAR OF CONSTRUCTION DEBRIS AND CLEARLY MARKING THE PATH OF EGRESS TRAVEL.
- ALL MECHANICAL (HVAC), ELECTRICAL, AND PLUMBING (MEP) DESIGN AND CONSTRUCTION TO BE BY A DESIGN-BUILD DELIVERY METHOD AND ARE SUBSEQUENTLY NOT PART OF THESE DOCUMENTS. IT IS THE MEP CONTRACTOR'S RESPONSIBILITY TO COORDINATE WITH THE GENERAL CONTRACTOR AND WITH THESE DRAWINGS THE FINAL DESIGN, RETROFIT AND INSTALLATION OF THESE SYSTEMS. NOTIFY THE ARCHITECT PRIOR TO MAKING ANY REVISIONS TO THE STRUCTURE OR ARCHITECTURAL FEATURES.
- HVAC CONTRACTOR SHALL SUBMIT PROPER DESIGN DRAWINGS AS NEEDED FOR PLAN APPROVAL AND BUILDING PERMITS.
- WITHIN THIS DOCUMENT "NORTH, SOUTH, EAST, WEST" ARE REFERRED TO AS PROJECT NORTH AND MAY NOT BE TRUE NORTH.
- ALL EXPOSED WOOD AND/OR WOOD IN CONTACT WITH CONCRETE OR MASONRY SHALL BE PRESSURE TREATED.
- PROVIDE GFI OUTLETS NEAR WATER SOURCES AND AS REQUIRED BY IEC.
- PROVIDE FIRE BLOCKING THROUGHOUT BUILDING PER IBC 717.2.
- SUBMIT ALL FIXTURES, APPLIANCES, MATERIALS, SHOP DRAWINGS, PLAN MODIFICATIONS TO THE ARCHITECT FOR REVIEW AND APPROVAL.

SHEET INDEX			
SHEET NUMBER	SHEET NAME	REVISIONS	
		MARK	DATE
GENERAL			
G001	COVER SHEET		
G002	FIRE SEPARATION & EGRESS PATH		
CIVIL			
1	SITE PLAN		
2	LANDSCAPING PLAN		
STRUCTURAL			
S001	STRUCTURAL NOTES		
S100	OVERALL BUILDING PLAN		
S101	FOUNDATION PLAN		
S102	CRANE LAYOUT/MASONRY WALL PLAN		
S103	RESTROOM PLAN		
S601	CONCRETE DETAILS		
S602	CONCRETE DETAILS		
S603	CONCRETE DETAILS		
S701	MASONRY DETAILS		
S702	MASONRY DETAILS		
ARCHITECTURAL GENERAL			
A001	SYMBOLS & ABBREVIATIONS		
A002	INTERIOR PARTITION TYPES		
ARCHITECTURAL DEMOLITION			
AD101	DEMOLITION FLOOR PLAN		
ARCHITECTURAL			
A101	OVERALL FLOOR PLAN		
A102	ENLARGED FLOOR PLAN		
A103	REFLECTED CEILING PLAN		
A104	ROOF PLAN		
A201	OVERALL EXTERIOR ELEVATIONS		
A202	ENLARGED EXTERIOR ELEVATIONS		
A301	BUILDING SECTIONS		
A302	WALL SECTIONS		
A303	WALL SECTIONS		
A401	ENLARGED FLOOR PLANS		
A501	PLAN AND SECTION DETAILS		
A502	SECTION DETAILS		
A601	DOOR AND WINDOW SCHEDULES		
PLUMBING			
P101	PLUMBING LINE PLAN		

DEDUCT ALTERNATE BIDS		
#	SHEET NUMBER	DESCRIPTION
1	A102	PROVIDE PRICING DEDUCT TO REMOVE ALL WASH BAY EQUIPMENT FROM PROJECT. REMOVE HOTSY PRESSURE WASHING SYSTEM, ASSOCIATED PIPING AND EQUIPMENT.
2	A102	PROVIDE PRICING DEDUCT TO REMOVE BRIDGE CRANE AND ASSOCIATED STRUCTURE/EQUIPMENT FROM PROJECT. REMOVE 3-TON BRIDGE CRANE, ALL RUNAWAYS, COLUMNS AND BRACKETS REQUIRED.
3	A102	SCHEDULE FLEXIBILITY- SEE SPECIFICATIONS FOR DETAILS

### PROJECT LOCATION

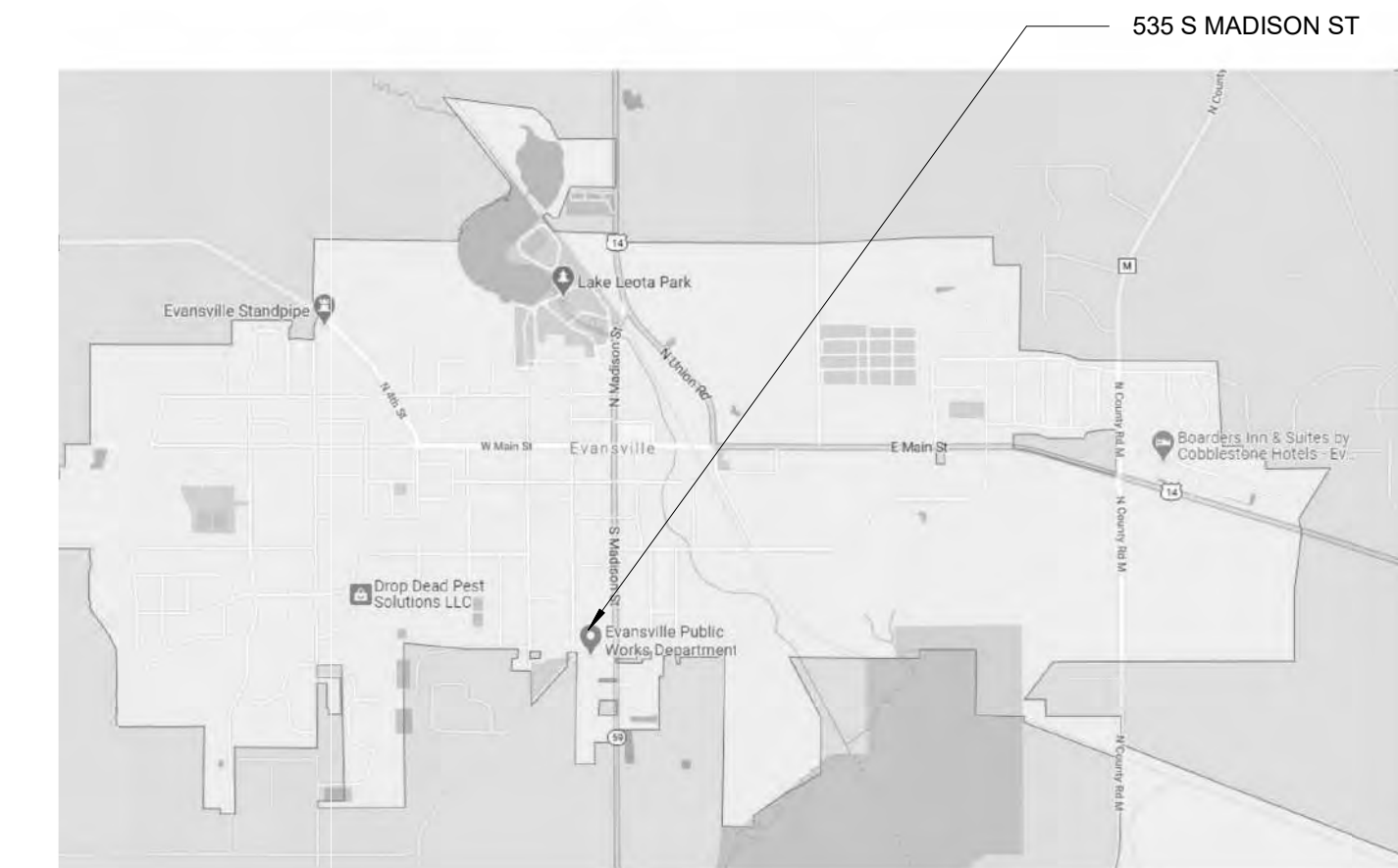

### BUILDING LOCATION

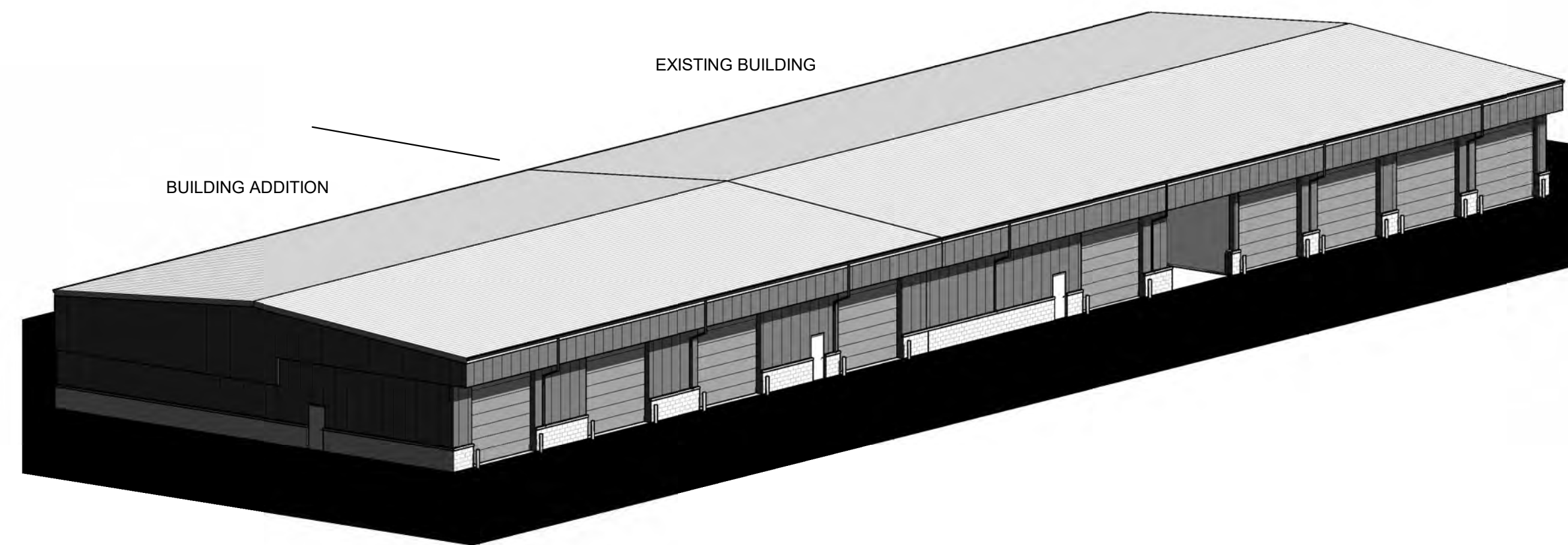

**CITY OF EVANSVILLE**  
**BUILDING ADDITION**  
**15 OLD HWY 92**  
**EVANSVILLE, WI**

### Project Status

2021.03.19	FOR CONSTRUCTION
------------	------------------

PROJ. #: 20119-01

© SKETCHWORKS ARCHITECTURE 2020

**COVER SHEET**

**G001**

**FOR CONSTRUCTION**

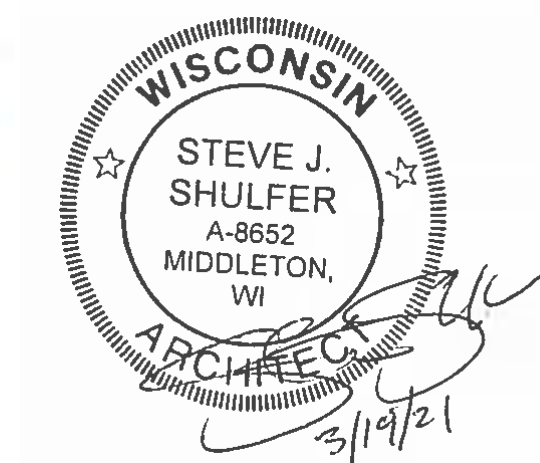

### PROJECT CONTACTS:

**OWNER:**  
EVANSVILLE PUBLIC WORKS DEPARTMENT  
535 S MADISON ST  
EVANSVILLE, WI 53536

**ARCHITECT:**  
SKETCHWORKS ARCHITECTURE, LLC  
7780 ELMWOOD AVE., STE 208  
MIDDLETON, WI 53562

**CIVIL ENGINEER:**  
TOWN & COUNTRY ENGINEERING, INC.  
2912 MARKETPLACE DRIVE, SUITE 103  
MADISON, WI 53719

**STRUCTURAL ENGINEER:**  
MP SQUARED, LLC  
583 D'ONOFRIO DR UNIT 201  
MADISON, WI 53719

**CONTACT:**  
CHAD RENLY  
608-882-2270

**CONTACT:**  
STEVE SHULFER (ARCHITECT)  
NICK BADURA (PM / CONTACT)  
608-836-7570

**CONTACT:**  
BRIAN BERQUIST  
608-273-3350

**CONTACT:**  
MARK LINDLOFF  
608-821-4770



**FIRE SEPARATION NOTES:**

A. 3 HOUR FIRE BARRIER TO SEPARATE FIRE AREAS  
(MAX. 12,000 SF)

**FIRE SEPARATION RATINGS:**

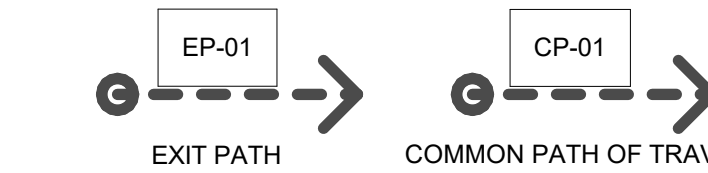
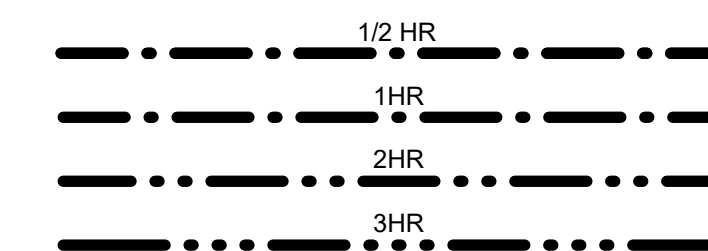

**EXIT TRAVEL DISTANCE  
IBC 2015 TABLE 1017.2**

PATH MARK	TRAVEL DISTANCE	COMMENTS
EP-01	93'-0"	200'-0" MAX
EP-02	28'-0"	200'-0" MAX

**COMMON PATH OF TRAVEL  
IBC 2015 TABLE 1006.2.1**

PATH MARK	TRAVEL DISTANCE	COMMENTS
CP-01	25'-6"	75'-0" MAX

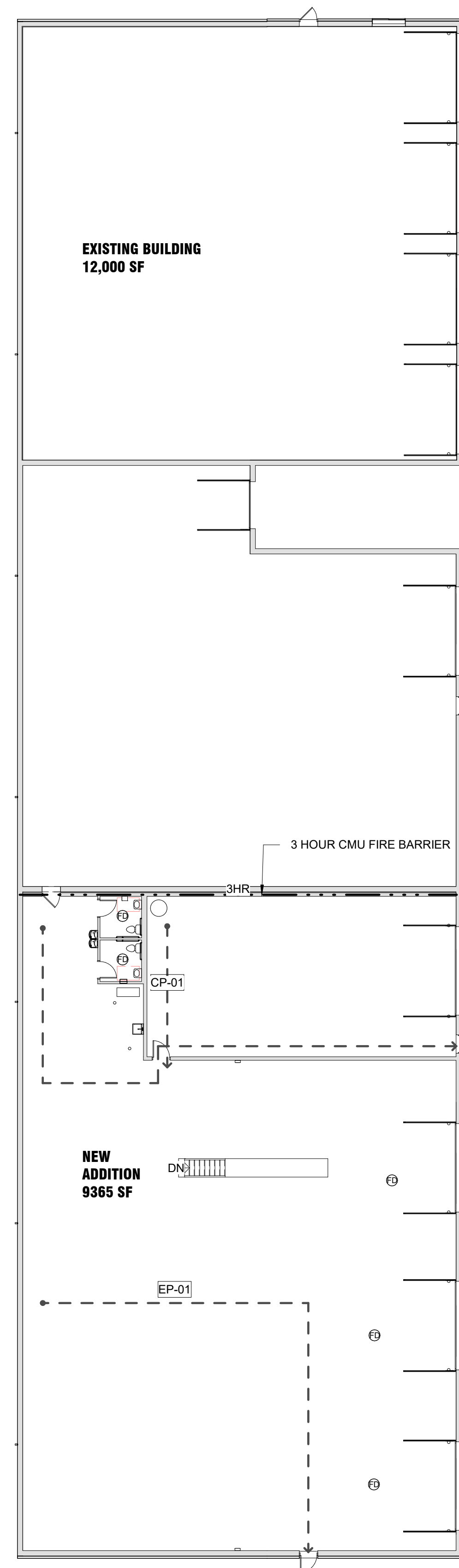

**CITY OF EVANSVILLE**  
BUILDING ADDITION  
15 OLD HWY 92  
EVANSVILLE, WI

**Project Status**

DATE	STATUS
2021.03.19	FOR CONSTRUCTION

PROJ. #: 20119-01

© SKETCHWORKS ARCHITECTURE 2021

**FIRE SEPARATION & EGRESS PATH**

**G002**

**A3** EGRESS PLAN  
1/16" = 1'-0"

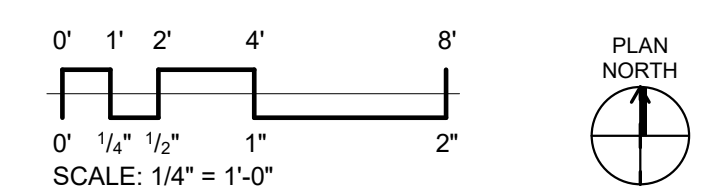

**FOR CONSTRUCTION**

**PRELIMINARY**

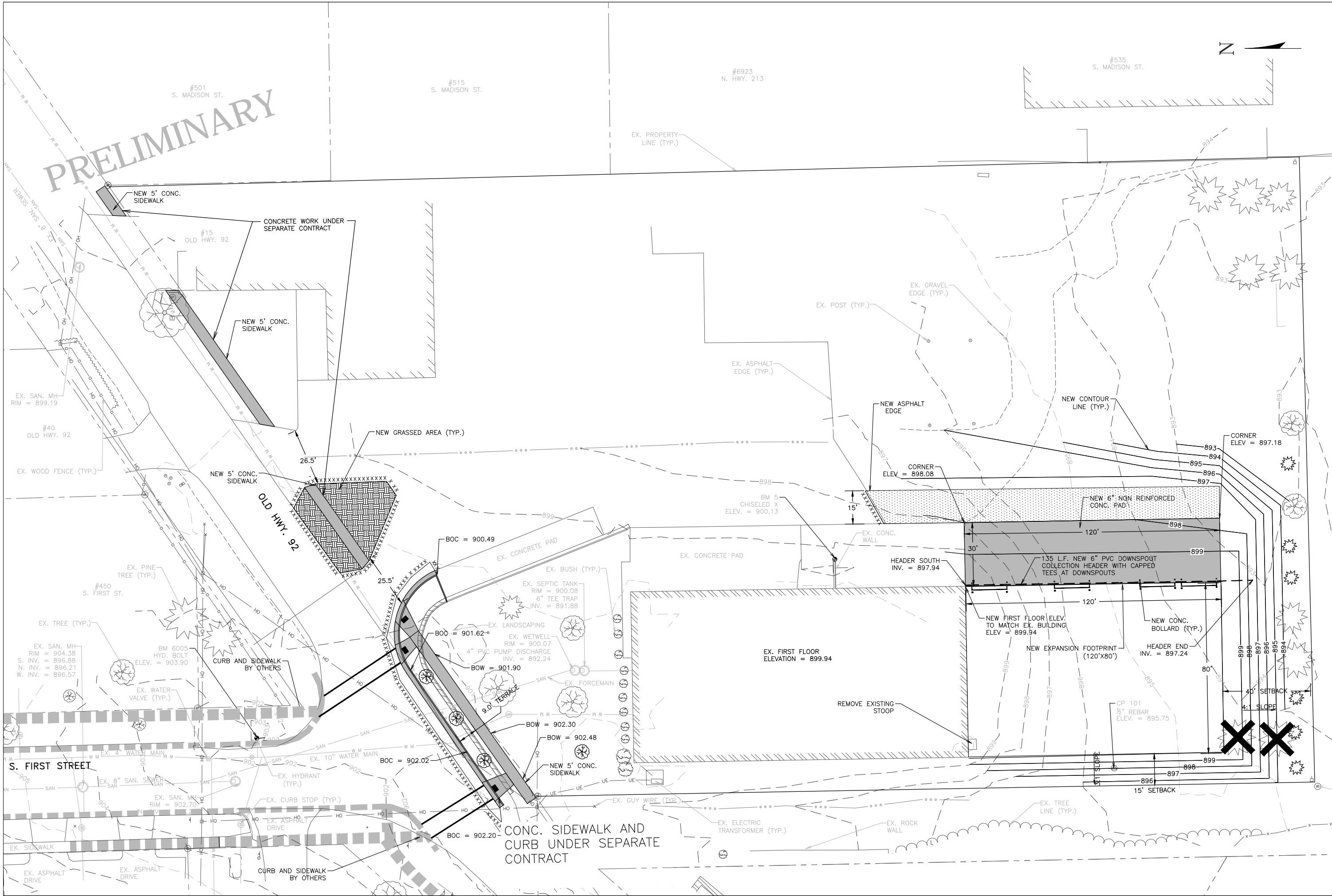

PROJECT NO.:	EV 89
DRAWING FILE:	EV 89 BASE.DWG
DRAWN BY:	N.J.D.
CHECKED BY:	B.R.B.
DATE:	2-15-21
REVISIONS:	



PRELIMINARY

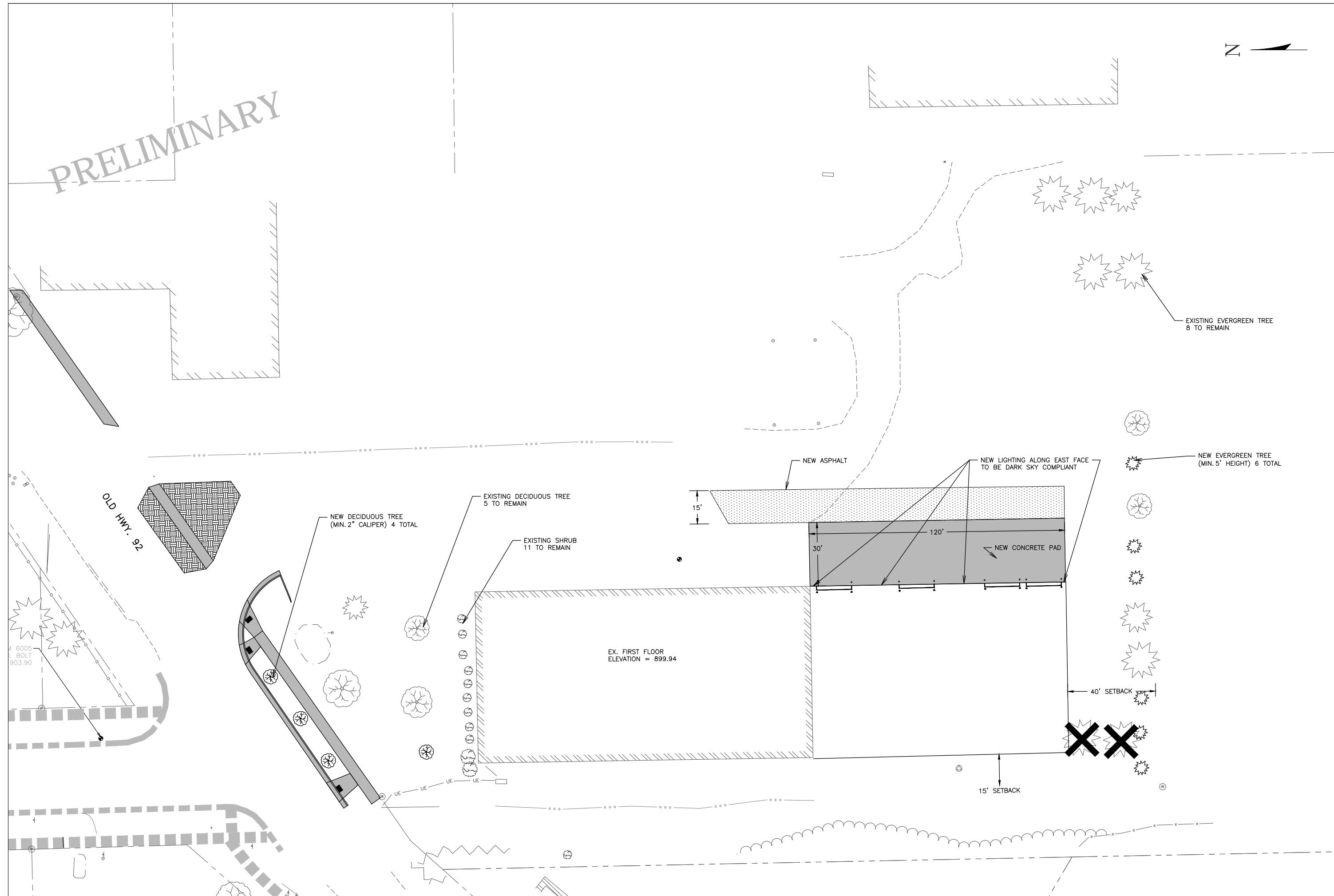

LANDSCAPING PLAN

2021 WATER AND LIGHT BUILDING SITE  
OLD HIGHWAY 92  
City of Evansville, Wisconsin

PROJECT NO.:	EV 89
DRAWING FILE:	EV 89 BASE.DWG
DRAWN BY:	N.J.D.
CHECKED BY:	B.R.B.
DATE:	2-15-21
REVISIONS:	

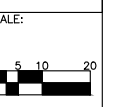



LOADING:

1. DESIGNED IN ACCORDANCE WITH THE CURRENT WISCONSIN COMMERCIAL BUILDING CODE BASED ON THE 2015 INTERNATIONAL BUILDING CODE.

DESIGN LOADS:

- A. ROOF DEAD LOAD: ROOF DECK & SECONDARY = 3.0 PSF FRAMES = 2.5 PSF
B. COLLATERAL GRAVITY = 8 PSF (INCLUDING ROOF PV ALLOWANCE) 3T CRANE SEE PLAN

C. ROOF LIVE LOAD: 20 PSF REDUCIBLE

D. DESIGN SNOW LOAD: Pg = 30 PSF Pf = 0.7(Ce)(Ct)(Pg) = 21 PSF Ce = 1.0 Cs = 1.0 Ct = 1.0 I = 1.0

DRIFTING & UNBALANCED SNOW PER CODE

D. WIND DESIGN CRITERIA ULTIMATE WIND SPEED = 115 MPH EXPOSURE = C I = 1.0 Kzt = 1.0

G. SEISMIC DESIGN CRITERIA

SEISMIC USE GROUP = I SITE CLASS = D Ss = 0.4%; S1 = 0.1% SDS = 0.090; SD1 = 0.082 SEISMIC DESIGN CATEGORY = B SEISMIC RESISTING SYSTEM = STRUCTURAL STEEL SYSTEMS SPECIFICALLY NOT DETAILED FOR SEISMIC DESIGN BASE SHEAR = 0.030\*W

- 1. THE CONTRACTOR SHALL FIELD VERIFY ALL DIMENSIONS AND EXISTING CONDITIONS PRIOR TO CONSTRUCTION...
2. THE CONTRACTOR IS RESPONSIBLE FOR LIMITING THE AMOUNT OF CONSTRUCTION LOAD IMPOSED UPON NEW OR EXISTING STRUCTURAL FRAMING...
3. THE STRUCTURE IS DESIGNED TO FUNCTION AS A UNIT UPON COMPLETION...
4. THE CONTRACTOR IS RESPONSIBLE FOR ALL MEANS AND METHODS OF CONSTRUCTION AND ALL JOB SITE SAFETY...
5. THE CONTRACTOR IS RESPONSIBLE FOR COORDINATION OF ALL BUILDING MATERIALS AND COMPONENTS...
6. THE CONTRACTOR SHALL BE RESPONSIBLE FOR FIELD VERIFICATION OF ALL CONDITIONS PRIOR TO BIDDING...
7. THE CONTRACTOR SHALL SUBMIT SHOP DRAWINGS...
8. MAXIMUM ALLOWABLE DEFLECTION CRITERIA:

FOUNDATION

- 1. PRESUMPTIVE ALLOWABLE SOIL BEARING CAPACITY = 2,000 PSF. THE STRUCTURAL ENGINEER MAKES NO WARRANTY AND ASSUMES NO LIABILITY REGARDING ACTUAL SOIL CONDITIONS...
2. PROJECT GEOTECHNICAL REPORT SUPERSEDES GEOTECHNICAL INFORMATION PROVIDED ON STRUCTURAL PLANS...
3. THE GENERAL CONTRACTOR (GC) SHALL BE RESPONSIBLE FOR ALL CONSTRUCTION PROCEDURES THAT MAY AFFECT ADJACENT EXISTING STRUCTURES, ROADS, OR OTHER SIGNIFICANT PROPERTY...
4. CONTRACTOR SHALL READ AND FOLLOW ALL RECOMMENDATIONS PROVIDED IN SOIL REPORT...
5. REFER TO THE GEOTECHNICAL INVESTIGATION FOR INFORMATION REGARDING REQUIRED UNDERCUT, EXCAVATION, SIDE SLOPES, SUB-GRADE PREPARATION, AND FILL RECOMMENDATIONS...
6. GRADE AREAS IN ACCORDANCE WITH ELEVATIONS AND GRADES SHOWN ON THE SITE DRAWINGS AND AS REQUIRED FOR DRAINAGE...
7. SLAB ON GROUND TO BE CONSTRUCTED ON A MINIMUM OF 6" OF CRUSHED STONE OR GRANULAR FILL...
8. ALL FILL MATERIAL USED IN GRADING OPERATIONS SHALL BE GRANULAR MATERIAL AND BE FREE OF DEBRIS...
9. THE BOTTOM OF ALL EXTERIOR FOOTINGS SHALL BE A MINIMUM OF 4"-0" BELOW FINISHED GRADE...
10. ALL FOUNDATIONS SHALL BEAR ON NATIVE SOIL OR COMPACTED GRANULAR FILL...
11. THE ENGINEER SHALL BE NOTIFIED IF ACTUAL FIELD CONDITIONS DO NOT MEET BEARING REQUIREMENTS...
12. ALL BEARING SOIL OR FILL MUST BE PROTECTED FROM FREEZING...
13. ALL SLABS ON GRADE AREAS SHALL BE PROOF ROLLED...
14. THE CONTRACTOR SHALL USE CONTROLLED GRANULAR FILL APPROVED BY THE GEOTECHNICAL ENGINEER...

15. WHEN IT IS POSSIBLE FOR GROUND WATER TO SEEP TOWARD SUBGRADE FOUNDATIONS AND RETAINING WALLS, THESE WALLS SHALL HAVE A POSITIVE DRAINAGE SYSTEM AT THE BASE OF THE WALL...
16. WHEN UNDERPINNING IS REQUIRED EXISTING FOOTINGS SHALL BE SEQUENTIALLY UNDERPINNED WITH UNDERMINED FOOTING SEGMENTS NOT TO EXCEED 4'-0" AT ANY TIME WITHOUT PRIOR AUTHORIZATION...
17. REMOVE TOPSOIL FROM BENEATH ALL PROPOSED CONSTRUCTION AREAS...

CONCRETE CONSTRUCTION

- 1. ALL CONCRETE DESIGN AND CONSTRUCTION SHALL CONFORM TO THE LOCAL BUILDING CODE REQUIREMENTS AND THOSE OF THE LATEST EDITION OF THE FOLLOWING STANDARDS: ACI 318, ACI 315, ACI 301, AND ACI 305 & 306.
2. ALL CONCRETE UNLESS SPECIFICALLY NOTED SHALL BE NORMAL WEIGHT (145 PCF) AND SHALL ACHIEVE A MINIMUM 28 DAY COMPRESSIVE STRENGTH (fc) AS FOLLOWS:
a. FOOTINGS BELOW FROST LINE: fc = 3,000 PSI
b. EXTERIOR FOUNDATION WALLS AND GRADE BEAMS THAT ARE EXPOSED TO FREEZING: fc = 4,000 PSI
c. INTERIOR AND EXTERIOR SLAB ON GROUND: fc = 4,000 PSI
d. SLAB ON GROUND WITH FOOT TRUCK TRAFFIC: fc = 4,000 PSI
e. CONCRETE BEAMS, JOIST, & COLUMNS: fc = 4,000 PSI
f. ALL OTHER CONCRETE: fc = 3,000 PSI
3. ALL CONCRETE SUBJECT TO EXTERIOR EXPOSURE SHALL BE AIR ENTRAINED TO 6% (+/- 1.5%) AND HAVE A MAXIMUM 1.5" AGGREGATE...
4. ALL SLABS ON GROUND SHALL BE A MINIMUM 5-BAG MIX AND SHALL UTILIZE 1.5 INCH TOP AGGREGATE...
5. CONCRETE SLABS ON GROUND CONTAINING REINFORCEMENT SHALL PLACE ALL REINFORCING BARS AND W/F ON CHAIRS...
6. ALL CONCRETE MIX DESIGNS SHALL MINIMIZE SHRINKAGE AS MUCH AS IS PRACTICAL...
7. UNLESS THE MIX DESIGN INCLUDES THE USE OF SUPERPLASTICIZERS, CONCRETE WITH A SLUMP GREATER THAN 5" SHALL BE REFUSED.
8. ALL CONCRETE REINFORCING STEEL TO BE ASTM A615 GRADE 60...
9. ALL REINFORCING BARS AND W/F SHALL BE SET ON CHAIRS AND TIED IN PLACE.
10. AFTER CONCRETING HAS STARTED, IT SHALL BE CARRIED ON AS A CONTINUOUS OPERATION...
11. CONCRETING OPERATIONS SHALL BE CARRIED ON AT SUCH A RATE THAT THE CONCRETE IS AT ALL TIMES PLASTIC AND FLOWS READILY INTO SPACES BETWEEN REINFORCEMENT.
12. CONCRETE SHALL BE THOROUGHLY CONSOLIDATED BY SUITABLE MEANS...
13. CONCRETE SHALL BE CURED ABOVE 50°F (10°C) AND IN A MOIST CONDITION FOR AT LEAST THE FIRST SEVEN DAYS...
14. ALL FLAT WORK CONCRETE MUST BE CURED. FLAT WORK IS RECOMMENDED TO BE COVERED IMMEDIATELY FOLLOWING SAW CUTTING...
15. RETEMPERED CONCRETE, CONCRETE THAT HAS BEEN REMOVED AFTER INITIAL SET OR PARTIALLY HARDENED SHALL NOT BE USED IN THE STRUCTURE.
16. SLAB REINFORCING, BARS OR W/F, SHALL BE PLACED WITHIN 1"-1/2" OF THE TOP OF THE SLAB UNLESS NOTED OTHERWISE...
17. WHEN HAIRPIN TIES ARE SHOWN ON THE PLAN TO RESIST LATERAL FORCES AT THE BASE OF THE COLUMNS...
18. WHEN HAIRPIN TIES ARE SHOWN ON THE PLAN TO RESIST LATERAL FORCES AT THE BASE OF THE COLUMN...
19. WHEN HAIRPIN TIES ARE USED SPECIAL CARE MUST BE TAKEN TO INSURE ALL SLAB-ON-GRADE REINFORCING...
20. HAIRPIN TIES SHALL LAP ANCHOR BOLTS UNLESS SPECIFICALLY NOTED OR DETAILED OTHERWISE...
21. ALL LAPS SHALL BE "B" SPLICES UNLESS NOTED OTHERWISE...
22. ALL CONCRETE SHALL BE CURED FOR A MINIMUM OF SEVEN DAYS.
23. UNLESS OTHERWISE APPROVED, ALL EXPOSED CONCRETE WALLS SHALL BE CURED WITH FORMS LEFT IN PLACE...
24. WALL CRACKS DUE TO IMPROPER CURING METHODS, OR WEATHER PROTECTION SHALL BE THE RESPONSIBILITY OF THE CONTRACTOR.
25. ANCHOR BOLT DIAMETER AND PLACEMENT TO BE PER THE METAL BUILDING SUPPLIER'S DRAWINGS...
26. GROUT USED TO PROVIDE LEVEL BEARING OF COLUMN BASE PLATES SHALL BE NON-SHRINK, NON-METALLIC GROUT...
27. EPOXY FOR EPOXY GROUTED ANCHORS SHALL BE A TWO PART 100% SOLID EPOXY SUPPLIED AND DISPENSED THROUGH A STATIC MIXING NOZZLE...

28. UNLESS NOTED OTHERWISE ON THE DRAWINGS ALL REINFORCING SHALL BE LAPPED TO DEVELOP ITS CAPACITY AS FOLLOWS:

Table with 4 columns: CONCRETE COMPRESSIVE STRENGTH (fc=3,000 PSI), CONCRETE COMPRESSIVE STRENGTH (fc=4,000 PSI), STD DEVELOPMENT LENGTH, CLASS "B" TENSION LAP LENGTH. Includes rows for #3, #4, #5, #6, #7, #8 bars.

- 29. SLAB ON GRADE SHALL HAVE A CLASS "A" TOLERANCE.
30. A 10-MIL (MIN.) POLYETHYLENE VAPOR BARRIER WITH JOINTS LAPPED NOT LESS THAN 6" SHALL BE PLACED BETWEEN THE BASE COURSE OR SUBGRADE AND THE CONCRETE FLOOR.
31. CALCIUM CHLORIDE AND OR ADMIXTURES CONTAINING CALCIUM CHLORIDE SHALL NOT BE USED.
32. PLACING OF CONCRETE SHALL BE DONE IN CONFORMANCE WITH ACI-306 FOR COLD WEATHER AND ACI-305 FOR HOT WEATHER.
33. EXPOSED FOUNDATION WALLS SHALL HAVE VERTICAL CONTROL JOINTS SPACED NOT MORE THAN 25'- 0" ON CENTER...
34. EXPOSED FOUNDATION WALLS SHALL HAVE EXPANSION JOINTS LOCATED AT EVERY FOURTH CONTROL/CONTRACTION JOINT...
35. FLOOR SLAB CONTROL JOINTS SHALL FOLLOW THE INTENT SHOWN ON THE PLAN BUT SHALL NOT EXCEED AN ASPECT RATIO OF 1.5 TO 1.0...
36. WALL EXPANSION JOINTS ARE REQUIRED UNDER INDICATED ON THE DRAWINGS BUT NOT TO EXCEED 125 FEET.
37. NO TACK WELDING WILL BE PERMITTED ON ASTM A615 GRADE 40 OR 60 STEEL.
38. CONSTRUCTION JOINTS SHALL BE LOCATED AT CONTROL JOINTS OR CONTRACTION JOINTS.
39. PIPE SLEEVES OVER 1 1/2" IN DIAMETER WHICH PASS THROUGH CONCRETE WALLS OR SLABS SHALL BE SCHEDULE 40 GALVANIZED STEEL PIPE...
40. ALUMINUM CONDUIT SHALL NOT BE EMBEDDED IN CONCRETE.

PRE-ENGINEERED METAL BUILDING

- 1. ALL LOADS SHALL BE PROPORTIONED AND APPLIED IN ACCORDANCE WITH THE CURRENT WISCONSIN ENROLLED COMMERCIAL BUILDING CODE...
2. DEFLECTION REQUIREMENTS SHALL BE IN ACCORDANCE WITH THE APPLICABLE PROVISIONS OF THE AISC STEEL DESIGN GUIDE SERIES 3...
3. SUBMIT SEALED ANCHOR BOLT PLACEMENT PLAN AND COLUMN REACTIONS...
4. BUILDING COLUMN SIZES SHALL NOT EXCEED THOSE SHOWN ON PLAN OR PIER SIZE SHOWN...
5. THE METAL BUILDING SUPPLIER SHALL SUBMIT FRAME REACTIONS THAT INCLUDE UN-FACTORED REACTIONS...
6. THE BUILDING ERECTOR SHALL HAVE A MINIMUM OF THREE YEARS EXPERIENCE IN THE ERECTION OF STEEL BUILDING SYSTEMS...
7. THE ERECTOR SHALL FURNISH TEMPORARY GUYS AND BRACING WHERE NEEDED FOR SQUAREING, PLUMBING, AND SECURING THE STRUCTURAL FRAMING AGAINST LOADS...

MISCELLANEOUS

- 1. ALL DRAWINGS ARE OF EQUAL IMPORTANCE IN DEFINING THE WORK OF THE CONTRACT DOCUMENTS...
2. EVERY EFFORT HAS BEEN MADE TO PROVIDE TO SCALE DRAWINGS...
3. ALL ANCHOR BOLTS SHOULD HAVE A MIN SPACING OF 6\*BOLT DIAMETER...
4. ALL WINDOW FRAMES SHALL BE INSTALLED TO ALLOW FOR A MINIMUM OF L/600 OR 1/2 INCH VERTICAL DEFLECTION...
5. DIMENSIONS OF EXISTING CONSTRUCTION OR CONSTRUCTION IN PROGRESS SHALL BE VERIFIED AND COORDINATED PRIOR TO FABRICATION OF STRUCTURAL COMPONENTS.

STRUCTURAL ABBREVIATIONS

Table mapping abbreviations to full names: AT ANCHOR BOLT, ACOM ACCOMMODATE, AGS AGGREGATE, ALT ALTERNATE ARCHITECT/ ARCHITECTURAL, B-B BACK-TO-BACK BUILDING LINE, BLDG BUILDING, BLK BLOCK, BM BEAM, BOT BOTTOM, BRG BEARING, BS BOTH SIDES, C CHANNEL DESIGNATION, CB CATCH BASIN, C/C CENTER-TO-CENTER, CG CENTER OF GRAVITY, CI CAST IRON, CIP CAST IN PLACE, CJ CONTRACTION OR CONTRACTION JOINT, CL CONTROL JOINT, CLR CLEAR, CMU CONCRETE MASONRY UNIT, COL COLUMN, COMP COMPOSITE, CONC CONCRETE, CONN CONNECTION, CONT CONTINUOUS, CONTR CONTRACTION, D DEPTH, Ø DIAMETER, DIA DIAMETER, DIM DIMENSION, DN DOWN, DTL DETAIL, DWG DRAWING, DWL DOWEL, EA EACH, EC ELECTRICAL CONTRACTOR, EJ EXPANSION JOINT, EL ELEVATION, ELEV ELEVATOR, ENG ENGINEER, EQ EQUAL, EW EACH WAY, E-W EAST-WEST DIRECTION, EXST EXISTING, EXP EXPANSION, EXT EXTERIOR, FB FLANGE BRACE, FD FLOOR DRAIN, FDN FOUNDATION, FF FINISH FLOOR, FF-F FACE-TO-FACE, FL FRAME LINE, FLG FLANGE, FUT FUTURE, FV FIELD VERIFY, FTG FOOTING, GA GAGE, GALV GALVANIZED, GC GENERAL CONTRACTOR, GRD GRID LINE, HC HVAC CONTRACTOR, HOK HOOK, HM HOLLOW METAL, HZ HORIZONTAL, HP HIGH POINT, HT HEIGHT, HVAC HEATING, VENTILATING, & AIR CONDITIONING, HW HEADWELDED STUD, ID INSIDE DIAMETER, INSUL INSULATION, INT INTERIOR, JT JOINT, KB KNEE BRACE, L STEEL ANGLE DESIGNATION, LG LENGTH, LGMF LIGHT GAUGE METAL FRAMING, LLH LONG LEG HORIZONTAL, LVL LONG LEG VERTICAL, LP LOW POINT, LVL LAMINATED VENEER LUMBER, MAX MAXIMUM, MBR MASONRY BEARING WALL, MECH MECHANICAL, MFG MANUFACTURE, MIN MINIMUM, MISC MISCELLANEOUS, MTL METAL, NIC NOT IN CONTRACT, NOM NOMINAL, NTS NOT TO SCALE, N-S NORTH-SOUTH DIRECTION, OC ON CENTER, OD OUTSIDE DIAMETER, OH OVER HEAD, OPP OPPOSITE, OS ONE SIDE, PC PLUMBING CONTRACTOR, P/C PRECAST/PRESTRESSED, PDF POWDER DRIVEN FASTENER, PEMB PRE-ENGINEERED METAL BUILDING, PERIM PERIMETER, P/F PRE-FORMED JOINT FILLER, PL PLATE, PLT PLATE, P/T POST-TENSIONED PROJ, PAVT PAVEMENT, R RADIUS, RC REINFORCED CONCRETE, R/F ROOF DRAIN, RENF REINFORCING REQUIRED, SCHED SCHEDULE, SIM SIMILAR, SHT SHEET, SPA SPACE/ SPACES, SPEC SPECIFICATION, SQ SQUARE, SSSL STAINLESS STEEL, STL STEEL, STR STRUCTURAL, TBE TRUSS BEARING ELEVATION, THK THICK, TOF TOP OF, TC TOP OF CURB ELEVATION, TL TOP OF LEDGE ELEVATION, TOP OF PIER ELEVATION, TP TOP OF WALL ELEVATION, TW TOP OF STEEL ELEVATION, TYP TOP OF SLAB ELEVATION, TYP TYPICAL, UNO UNLESS NOTED OTHERWISE, VERT VERTICAL, VIF VERIFY IN FIELD, W WIDTH, W/ WITH, W/O WITHOUT, WCJ WALL CONTROL JOINT, WD WOOD, WF WIDE FLANGE, WP WORKING POINT, WSBW WOOD STUD BEARING WALL, WWF WELDED WIRE FABRIC

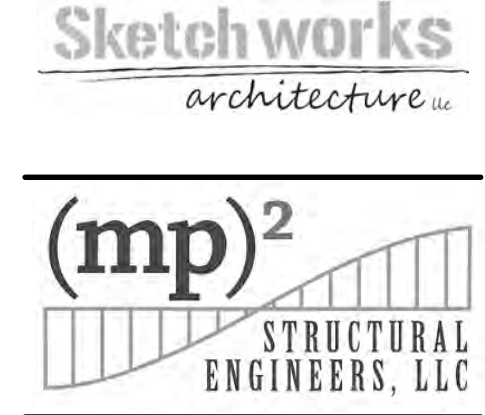

BUILDING ADDITION CITY OF EVANSVILLE 535 S MADISON ST EVANSVILLE, WI

Project Status table with columns for date and status: 1 03.19.2021 FOR CONSTRUCTION, 2 04.14.2021 REVISED LOAD NOTE

PROJ. #: 20001-01 © SKETCHWORKS ARCHITECTURE 2020

STRUCTURAL NOTES

S001

FOR CONSTRUCTION

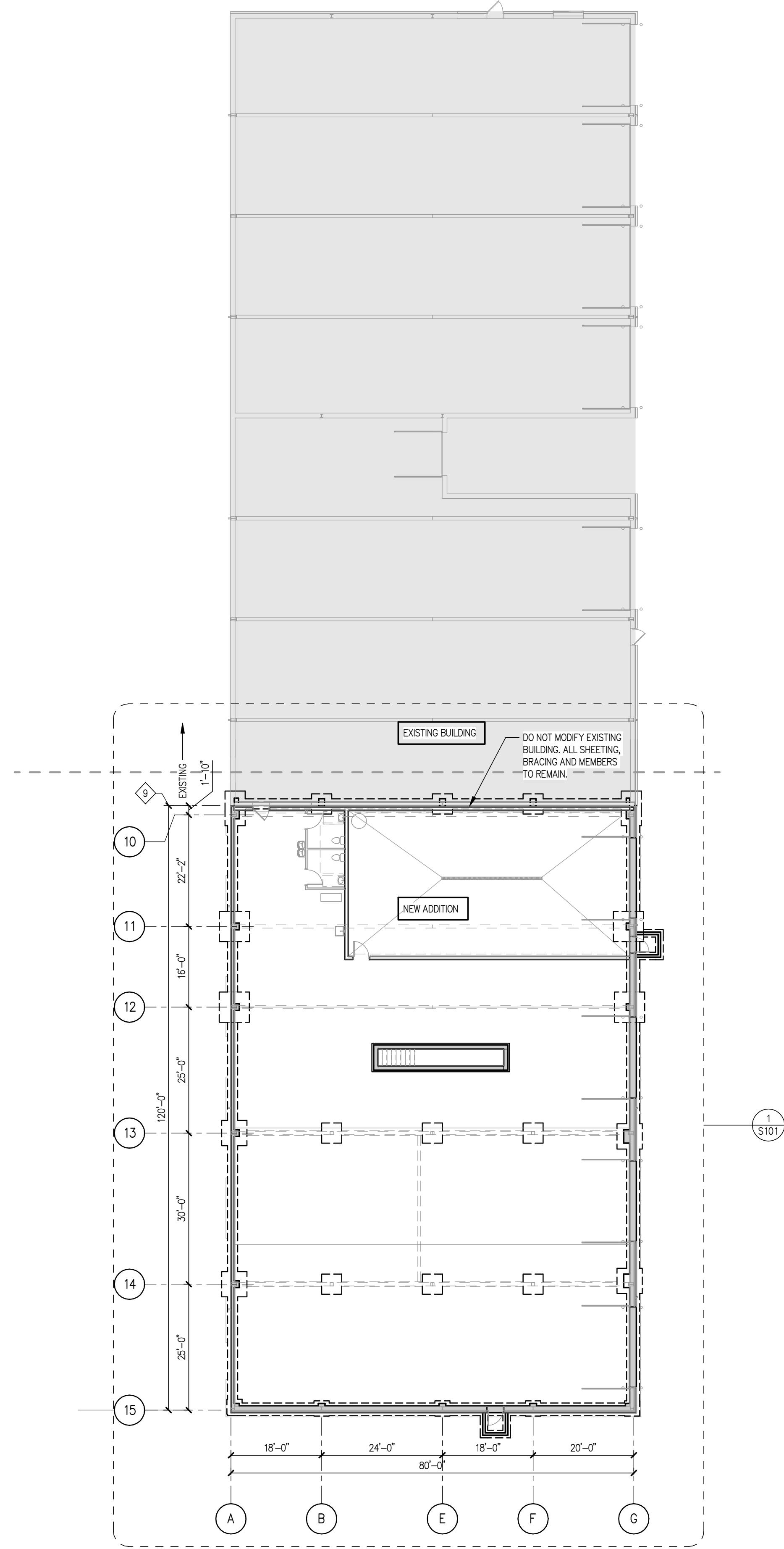

1 OVERALL BUILDING PLAN  
SCALE: 1/16" = 1'-0"

**BUILDING ADDITION**  
CITY OF EVANSVILLE  
535 S MADISON ST  
EVANSVILLE, WI

**Project Status**

1	03.19.2021	FOR CONSTRUCTION

PROJ. #: 20001-01

© SKETCHWORKS ARCHITECTURE 2020

**OVERALL BUILDING PLAN**

**S100**

**FOR CONSTRUCTION**

D  
C  
B  
A

FOUNDATION LEGEND

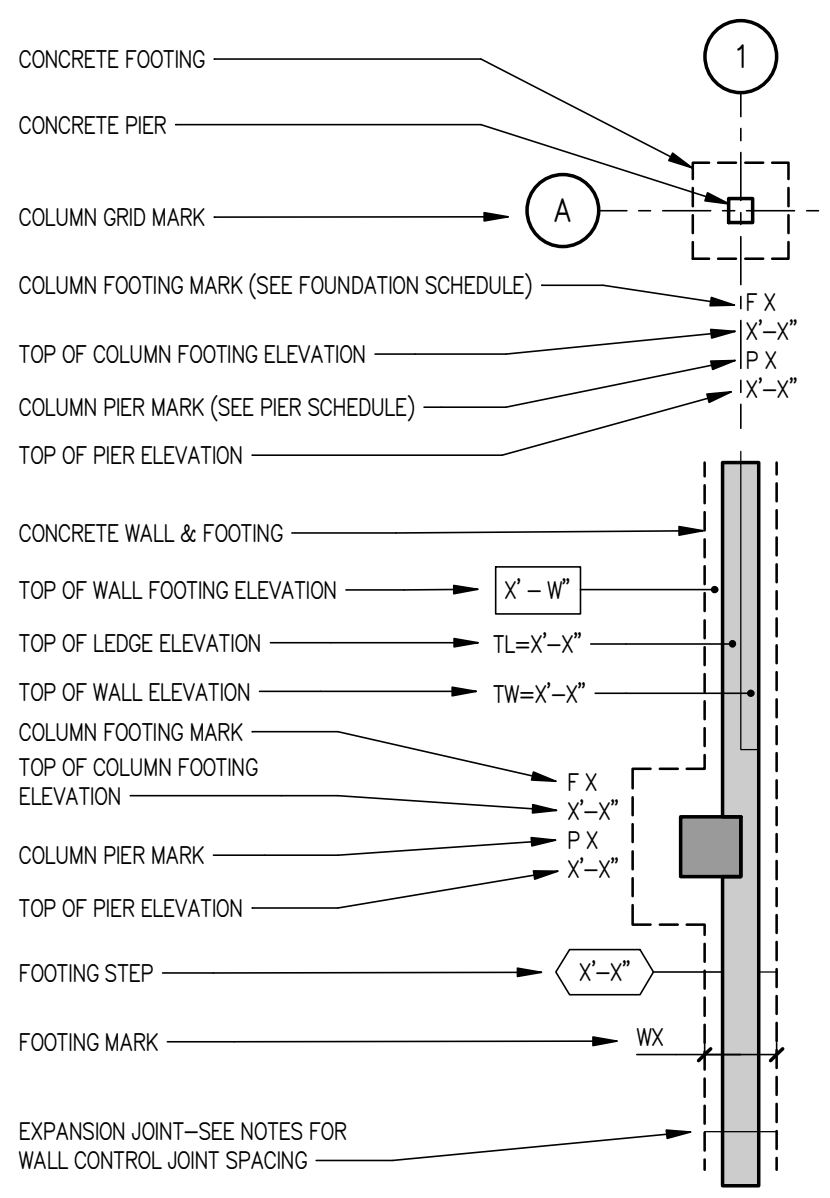

PLAN NOTES

- 1. SEE SHEET S001 FOR ADDITIONAL NOTES.
2. CONTROL JOINTS: ALL CONCRETE SLABS SHALL BE SAW CUT AS SOON AS THE CONCRETE WILL SUPPORT THE SAWING EQUIPMENT AND DOES NOT RAVEL DURING THE SAWING OPERATION. ALL SAW CUTTING SHALL BE PERFORMED THE SAME DAY THE CONCRETE IS PLACED. SAW CUTS SHALL BE 1/8" WIDE WITH DEPTHS OF AT LEAST 25% OF THE SLAB THICKNESS. JOINTING PATTERN SHALL BE IN A SQUARE PATTERN, WITH MAXIMUM SPACING OF 12'-0" FOR 4" THICK SLABS, 13'-0" FOR 5" THICK SLABS & 14'-6" FOR 6" THICK SLABS UNLESS NOTED OTHERWISE.
3. CURING: ALL CONCRETE FLAT WORK SHALL BE COVERED IMMEDIATELY FOLLOWING SAW CUTTING AND MAINTAINED CONTINUOUSLY WET FOR A MINIMUM OF 7 DAYS AFTER PLACING. CURING SHEETS SHALL BE USED, AND ARE TO REMAIN IN PLACE, DURING THIS PERIOD. CURING COMPOUND MAY BE USED AND MUST BE APPLIED PER MANUFACTURER'S RECOMMENDATIONS.
4. SEE SHEET S601 DETAIL 1 FOR ANCHOR BOLT REQUIREMENTS.
5. SEE SHEET S601 DETAILS 2 & 3 FOR FOOTING AND WALL CORNER REINFORCING REQUIREMENTS.
6. SEE SHEET S601 DETAILS 4 & 5 FOR ADDED REINFORCING AT ROUND & RECTANGULAR OPENINGS.
7. PROVIDE (2) #4 BARS AT ALL DEAD ENDS AND REINFRANT CORNERS, TYP. SEE SHEET S601 DETAIL 6 FOR ADDED REINFORCING AT REINFRANT CORNERS.
8. SLAB CONTROL JOINT SHALL BE AS SHOWN ON PLAN OR SIMILAR. SLAB JOINT ASPECT RATIO SHALL NOT EXCEED 1:1/2:1. SEE DETAIL 7/S601 FOR SLAB JOINT REQUIREMENTS.
9. PROVIDE CONTROL / EXPANSION JOINTS IN FOUNDATION WALL PER CONCRETE NOTES ON SHEET S001. LOCATE MID BAY BETWEEN COLUMNS. FOR FOUNDATION WALLS SEE DETAIL 8/S601.
10. VERIFY ALL WALL OPENINGS WITH ARCH & MECH SUBCONTRACTORS PRIOR TO POURING FOUNDATIONS. INSTALL SLEEVES / KNOCK OUT PANELS AS REQ'D.
11. SEE UNDERGROUND PLUMBING DRAWINGS FOR ALL UNDERGROUND PLUMBING REQUIREMENTS PRIOR TO POURING CONCRETE.
12. SEE DETAIL 12/S601 FOR ISOLATION JOINT AT COLUMNS.
13. SEE DETAILS 13 & 14/S601 FOR PIPE PENETRATION REQUIREMENTS.
14. TOP OF BRICK LEDGE = SEE PLAN. VERIFY W/ ARCH PLANS PRIOR TO PLACING FOUNDATION WALLS.
15. CONTRACTOR TO CONFIRM PEMB ANCHOR SETTINGS TO MATCH COLUMN LAYOUT & PLACEMENT SHOWN ON PLAN PRIOR TO PLACING CONCRETE OR SETTING ANCHORS.
16. HAIRPINS ARE INTEGRAL TO BUILDING STABILITY. FUTURE SLAB REMOVAL OR CUTTING SHALL BE REVIEWED BY A PROFESSIONAL ENGINEER TO VERIFY BUILDING STABILITY IS MAINTAINED.
17. SEE SHEET S701 FOR TYPICAL MASONRY DETAILS.
18. MASONRY WALLS ARE MW1 UNO.

FOOTING SCHEDULE

Table with 3 columns: FOOTING MARK, FOOTING DIMENSION (W x L x D), FOOTING REINFORCING, BOTTOM. Rows include F3.0, F4.0, F4.0 15, F5.0, and F6.0.

- 1. CENTER FOOTING UNDER COLUMN WHEN THE FOOTING IS COMBINED WITH A STRIP FOOTING, SUCH AS A RETAINING WALL, THE NET FOOTING SIZE MAY BE LARGER THAN EITHER INDIVIDUAL FOOTING, COMBINE AS SHOWN.
2. FINAL LOAD REACTIONS TO BE REVIEWED & APPROVED FOR COMPATIBILITY WITH THESE FOOTING SIZES BY A/E PRIOR TO CONSTRUCTION.

PIER SCHEDULE

Table with 5 columns: PIER MARK, PIER DESCRIPTION (W x L), PIER REINFORCING, TYPE, REFERENCE DETAIL. Rows include P1 through P8.

- 1. CENTER PIER UNDER COLUMN OR UNDER BEAM BEARING UNLESS NOTED OTHERWISE.
2. SEE DETAIL 4&5/S602 FOR TYPICAL PIER DETAILS.
3. PROVIDE DOWELS OF SAME SIZE & NUMBER AS VERTICAL REINFORCEMENT. MINIMUM LAP PER GENERAL NOTES WITH STANDARD AGI HOOK INTO FOOTING.

STRIP FOOTING SCHEDULE

Table with 4 columns: FOOTING MARK, FOOTING DIMENSION (W x D), FOOTING REINF, REMARKS. Rows include W1.5, W2.0, and W2.5.

- 1. CENTER FOOTING UNDER WALL, UNO.

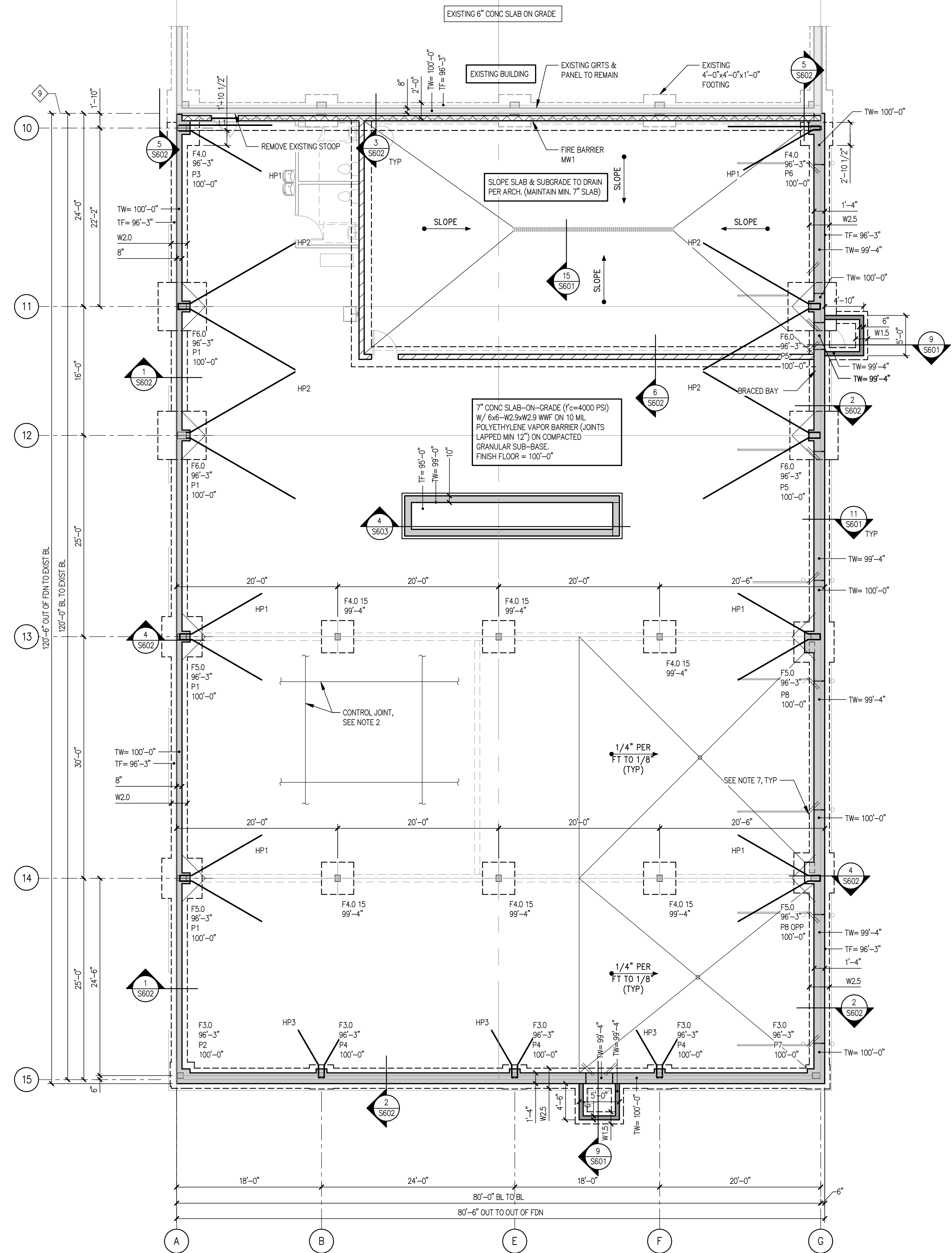

FOUNDATION PLAN SCALE: 1/8" = 1'-0"

Project Status

Table with 2 columns: ID, DATE, and STATUS. Row 1: 1, 03.19.2021, FOR CONSTRUCTION.

PROJ. #: 20001-01

© SKETCHWORKS ARCHITECTURE 2020

FOUNDATION PLAN

S101

FOR CONSTRUCTION

D  
C  
B  
A

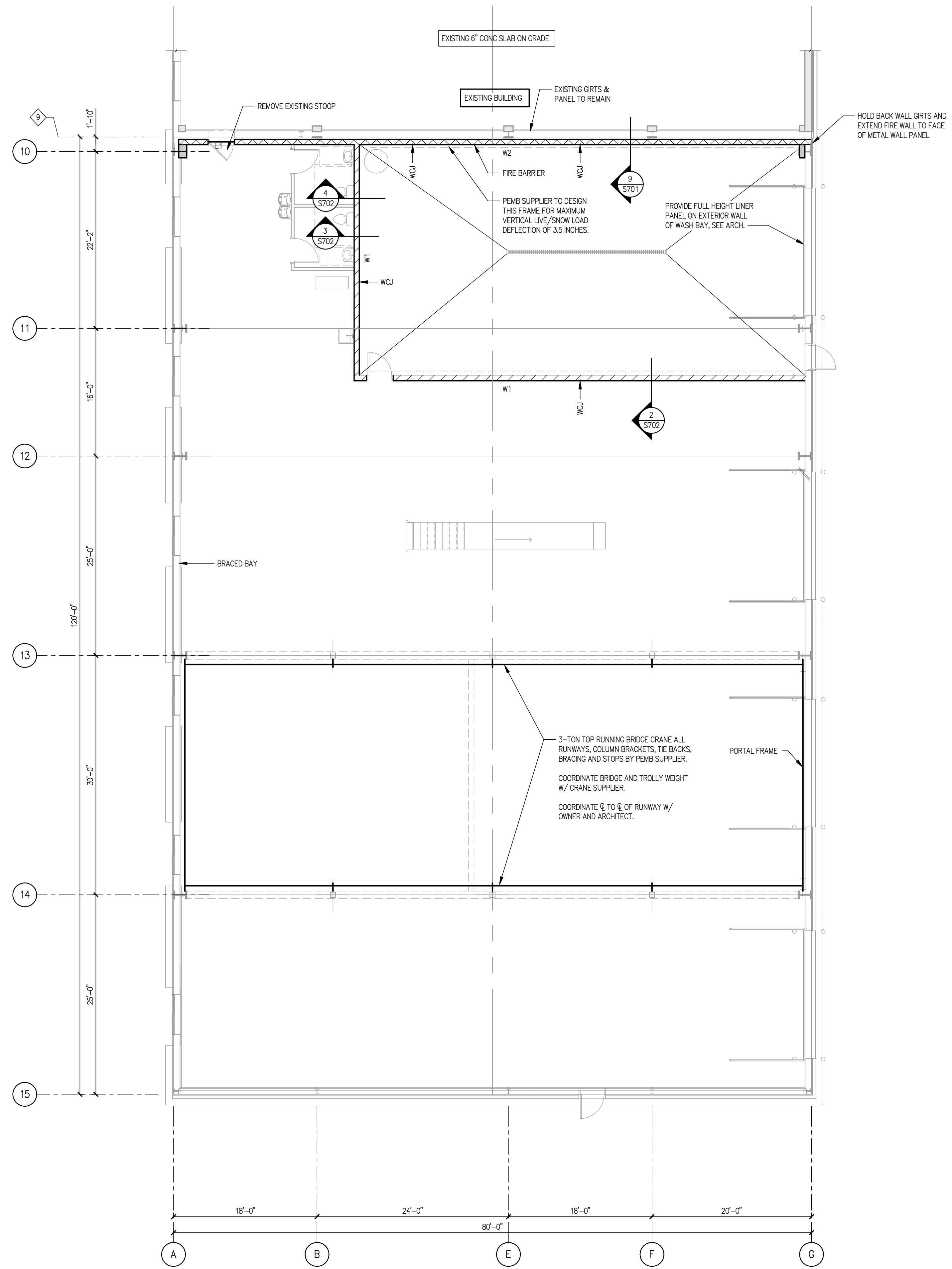

1  
S102 SCALE: 1/8" = 1'-0"

CRANE LAYOUT/MASONRY WALL PLAN

**BUILDING ADDITION**  
CITY OF EVANSVILLE  
535 S MADISON ST  
EVANSVILLE, WI

**Project Status**

NO.	DATE	DESCRIPTION
1	03.19.2021	FOR CONSTRUCTION

PROJ. #: 20001-01

© SKETCHWORKS ARCHITECTURE 2020

**CRANE LAYOUT/MASONRY WALL PLAN**

**S102**

**FOR CONSTRUCTION**

1

2

3

4

D

C

B

A

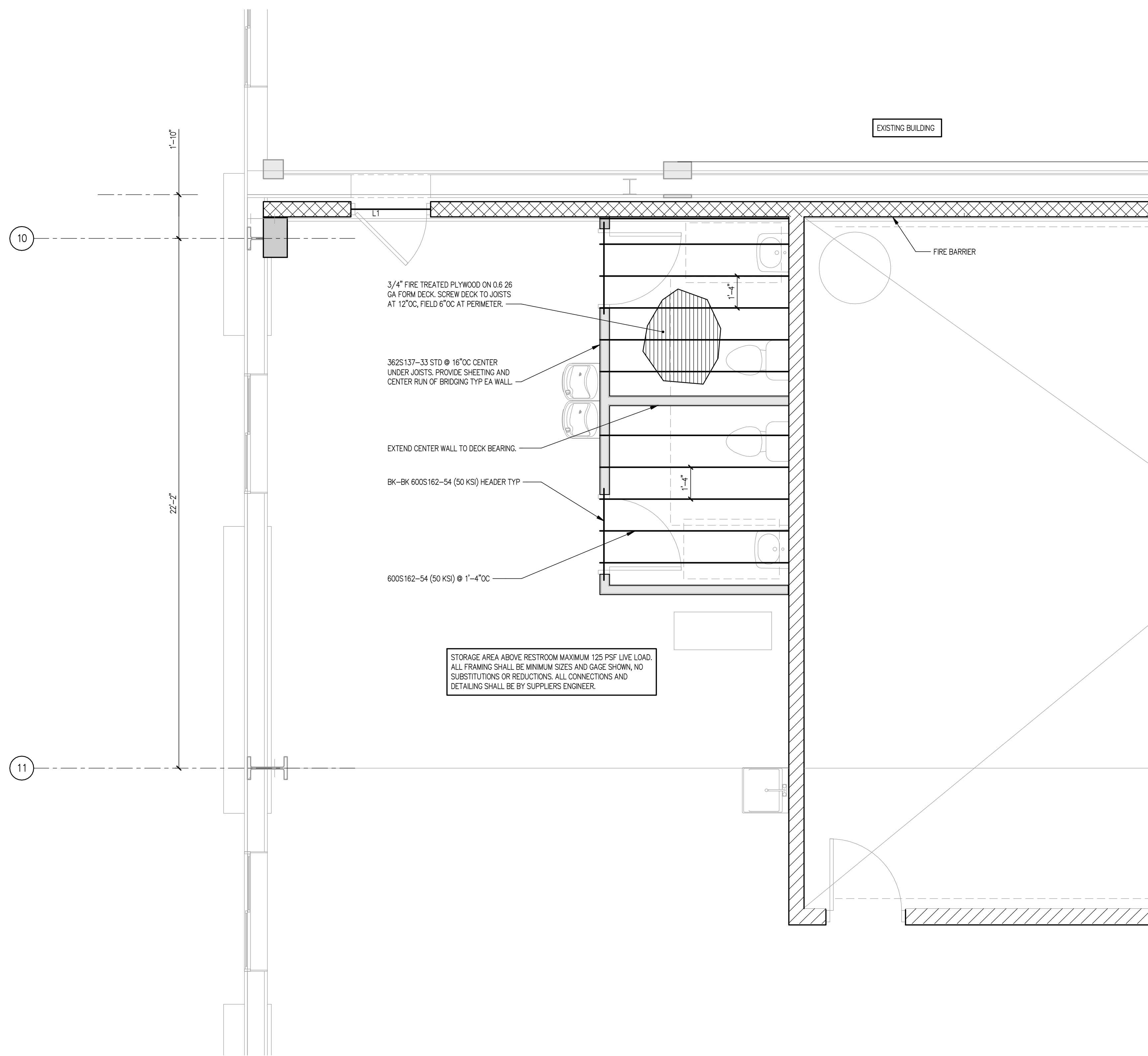

**1** CRANE LAYOUT/MASONRY WALL PLAN  
 S103 SCALE: 3/8" = 1'-0"

**BUILDING ADDITION**  
 CITY OF EVANSVILLE  
 535 S MADISON ST  
 EVANSVILLE, WI

**Project Status**

1	03.19.2021	FOR CONSTRUCTION

PROJ. #: 20001-01

© SKETCHWORKS ARCHITECTURE 2020

**RESTROOM PLAN**

**S103**

**FOR CONSTRUCTION**



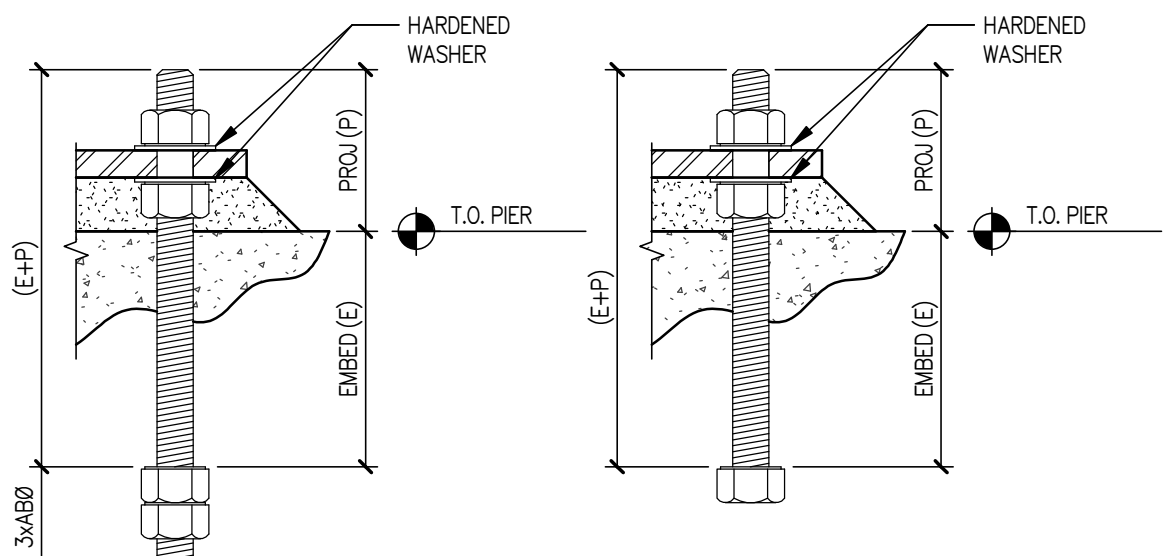

ANCHOR BOLT DIMENSION CHART			
DIAMETER	(E+P)	EMBEDMENT (E)	PROJECTION (P)
1/2"	12	8	4
3/4"	16	12	4
1"	19	15	4

NOTES:  
1. ALL ANCHORS F 1554, GRADE 36 UNO.  
2. GROUT GC OPTION AT PEMB.  
3. LENGTH = 1'-0" AT INTERIOR COLUMN FOOTINGS WITH 12" DEPTH.

1 ANCHOR BOLT DIMENSION CHART  
SCALE: 3/4" = 1'-0"

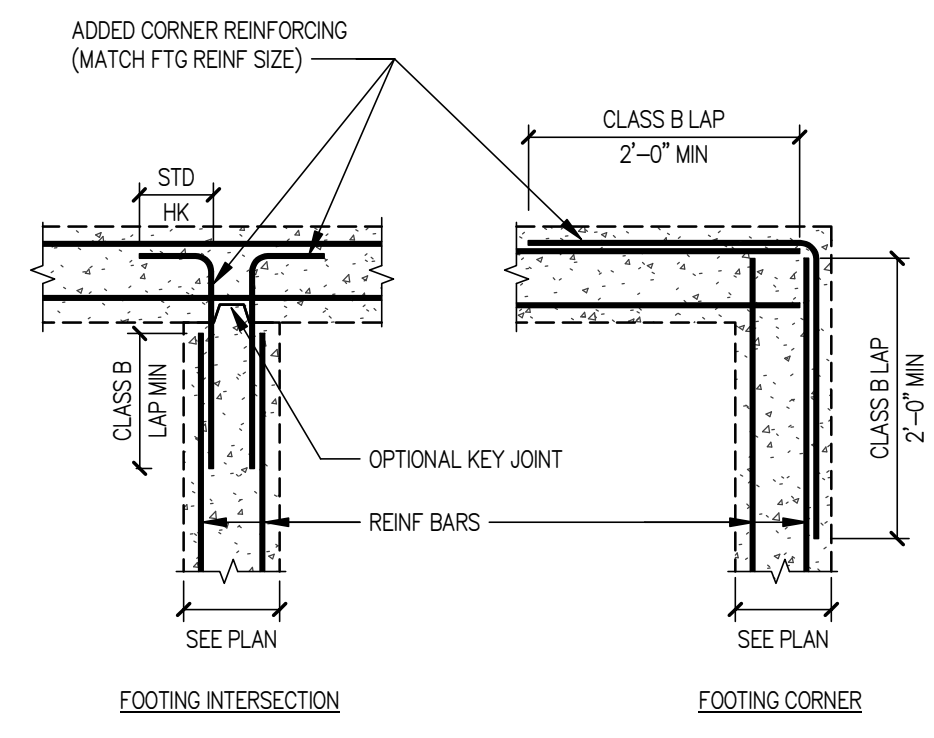

2 FOOTING CORNER REINFORCING  
SCALE: 3/4" = 1'-0"

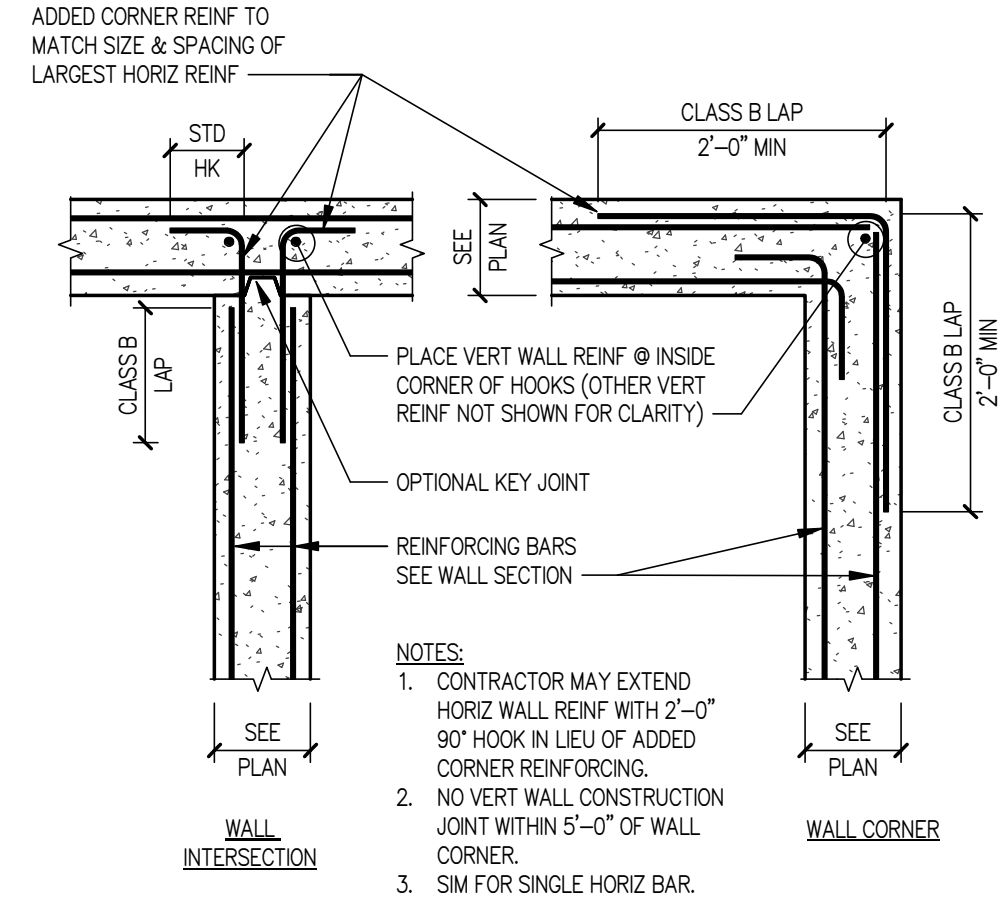

3 WALL CORNER REINFORCING  
SCALE: 3/4" = 1'-0"

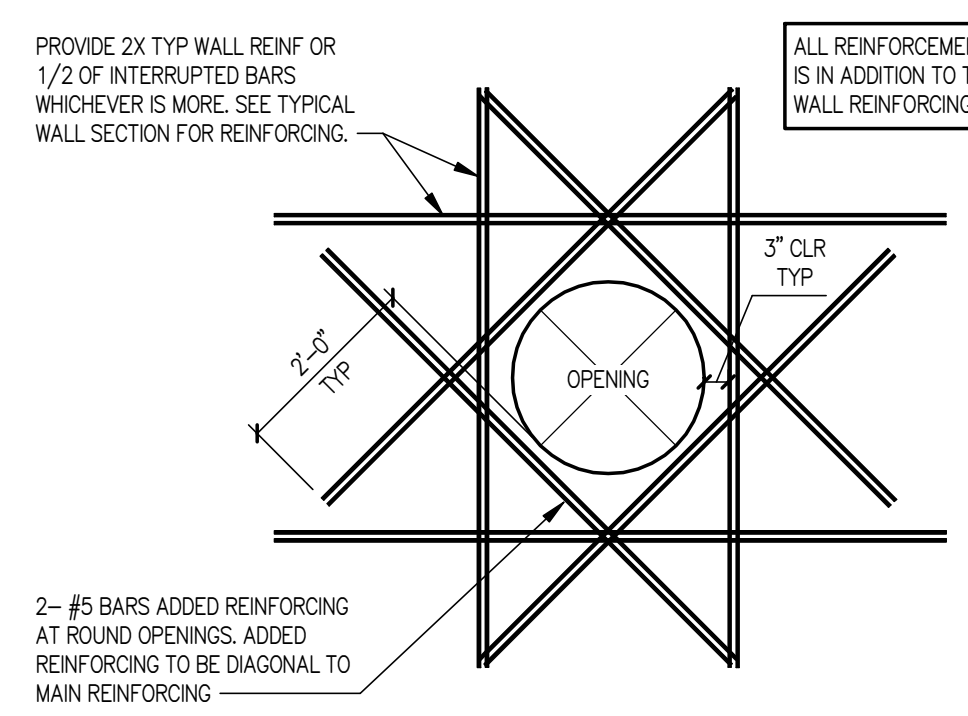

4 ADDED REINFORCING AT ROUND OPENINGS  
SCALE: 1/2" = 1'-0"

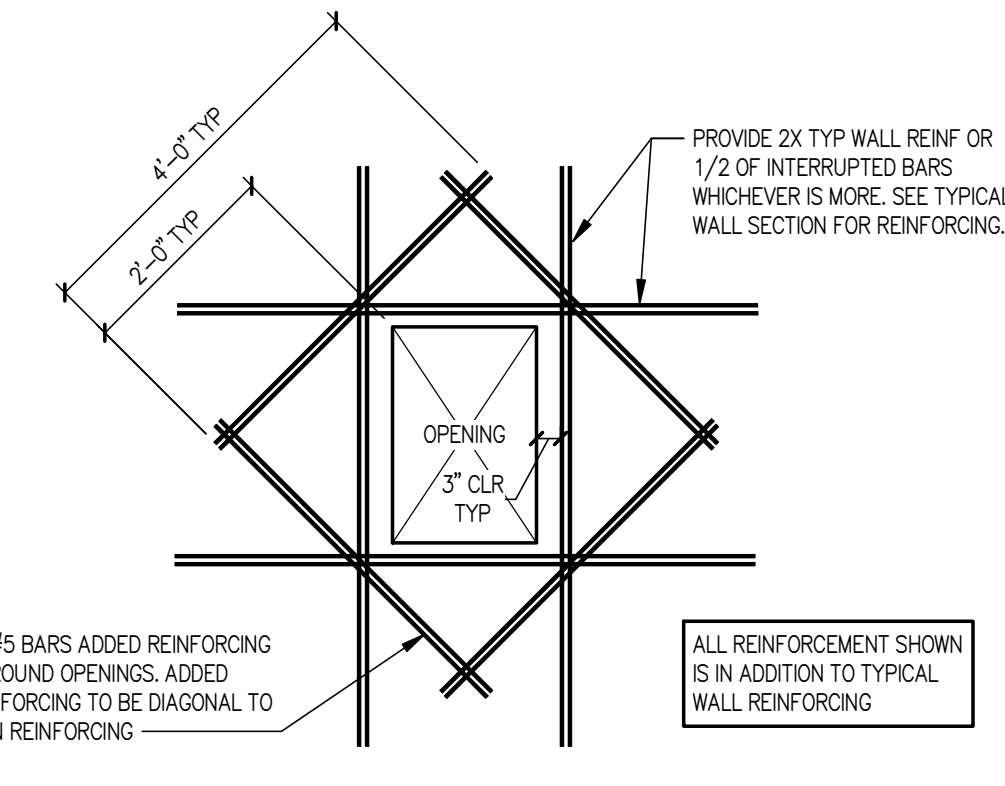

5 ADDED REINFORCEMENT AT RECTANGULAR OPENINGS  
SCALE: 1/2" = 1'-0"

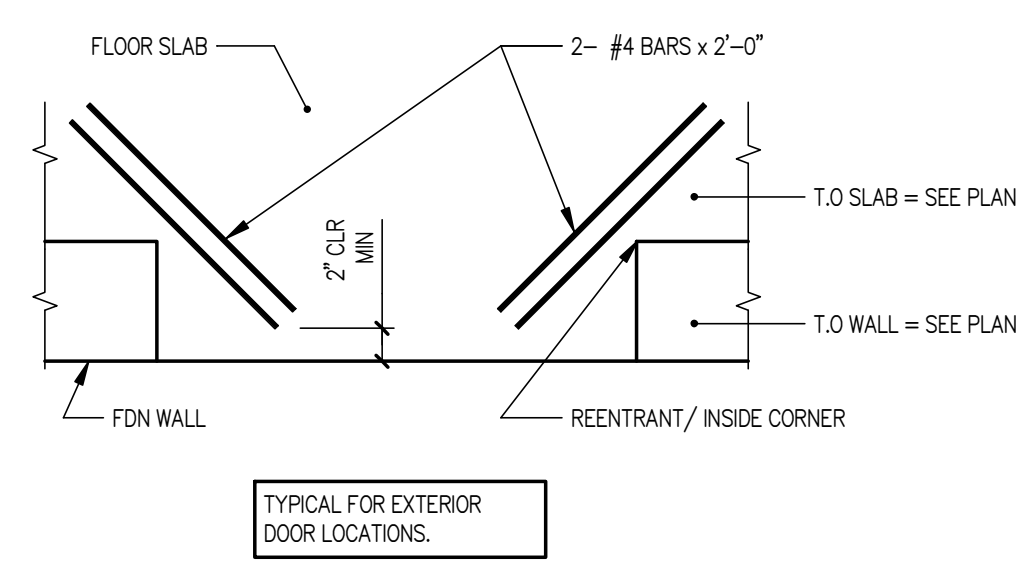

6 SLAB REINF AT REENRANT CORNERS W/O CONTROL JTS  
SCALE: 3/4" = 1'-0"

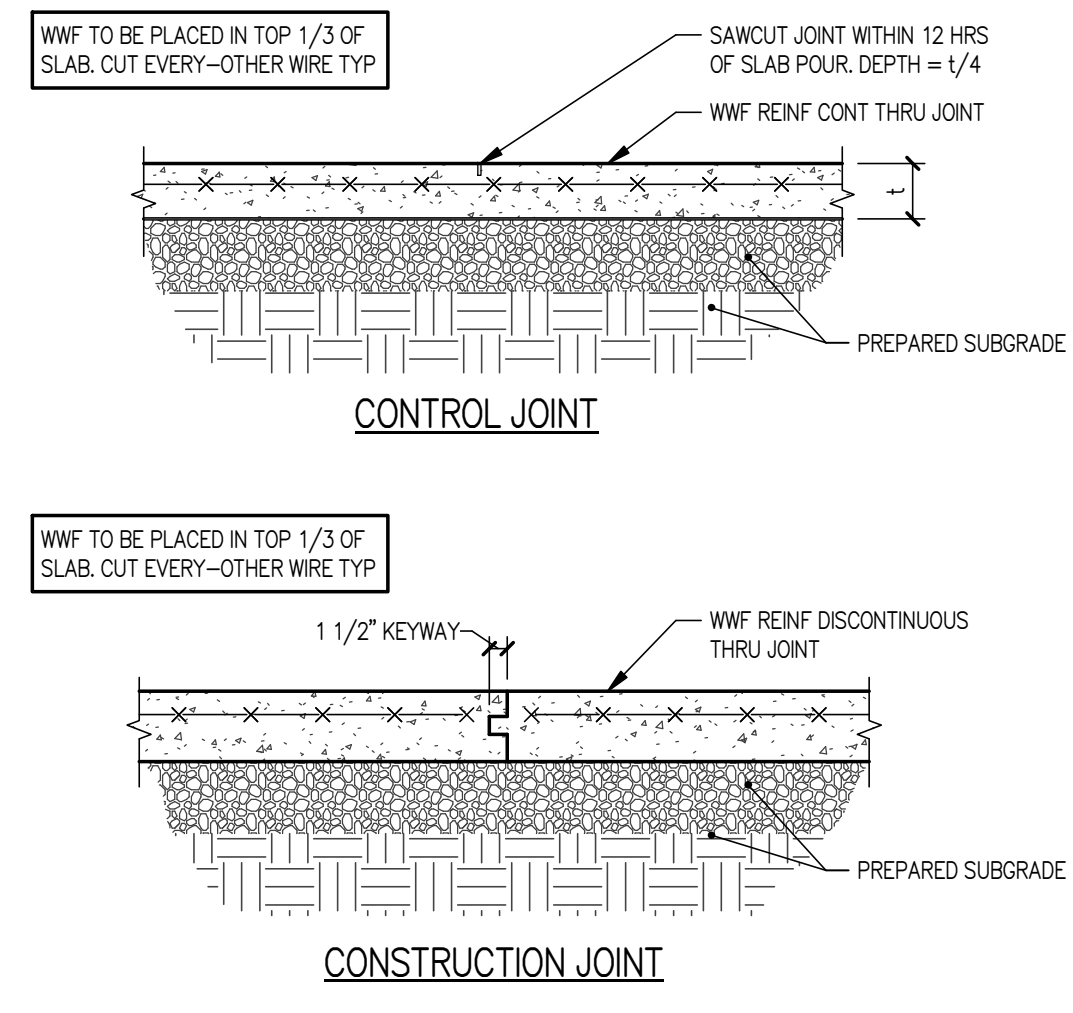

7 SLAB JOINTS  
SCALE: 3/4" = 1'-0"

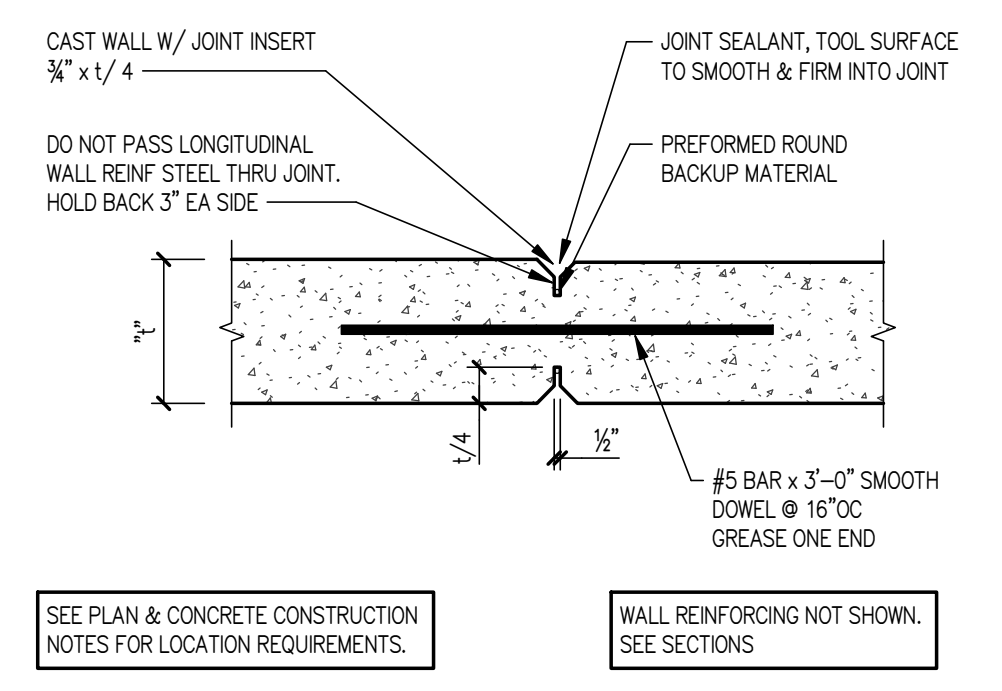

8 WALL CONTROL JOINT  
SCALE: 3/4" = 1'-0"

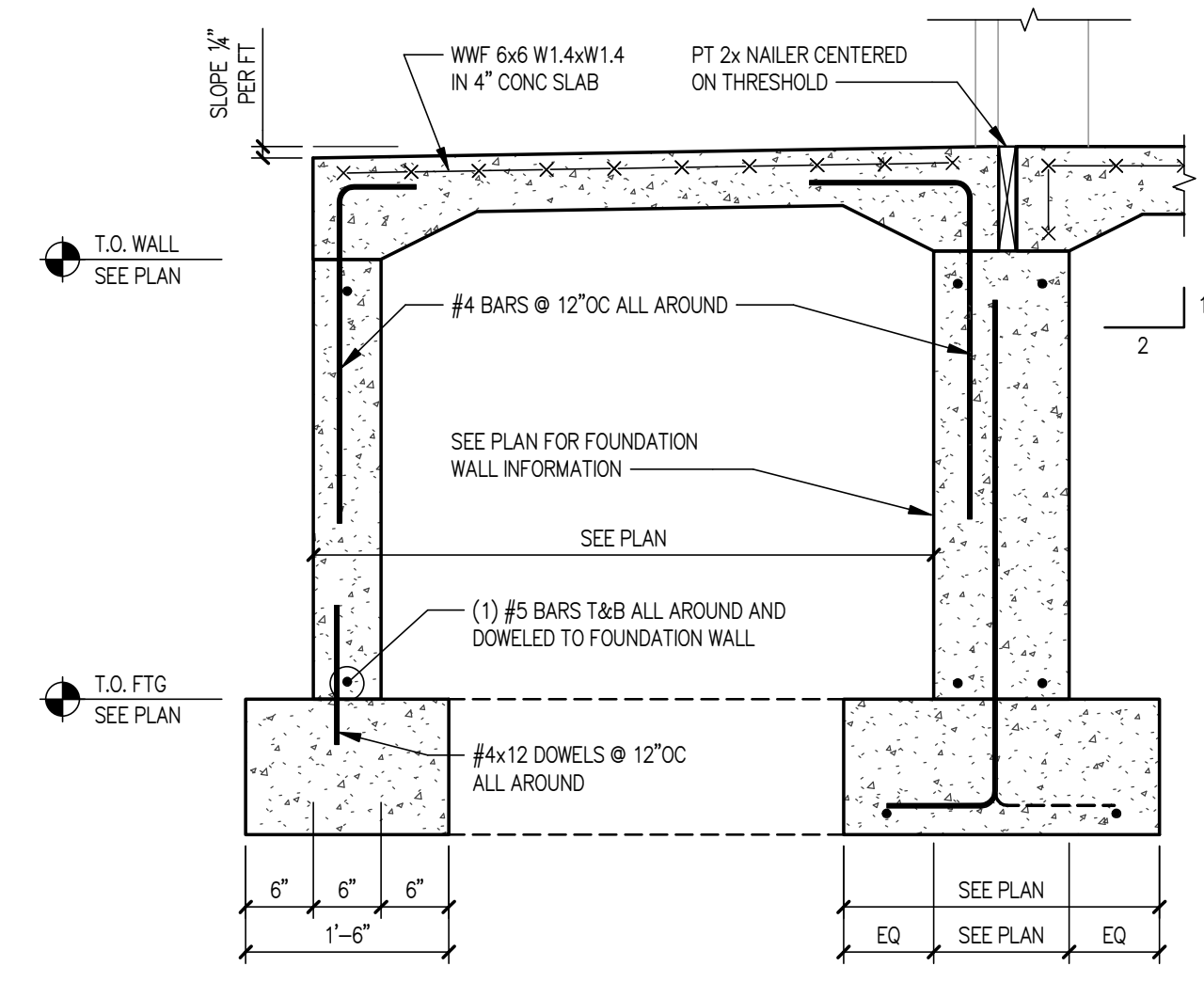

9 STOOP AT DOOR/WINDOW  
SCALE: 3/4" = 1'-0"

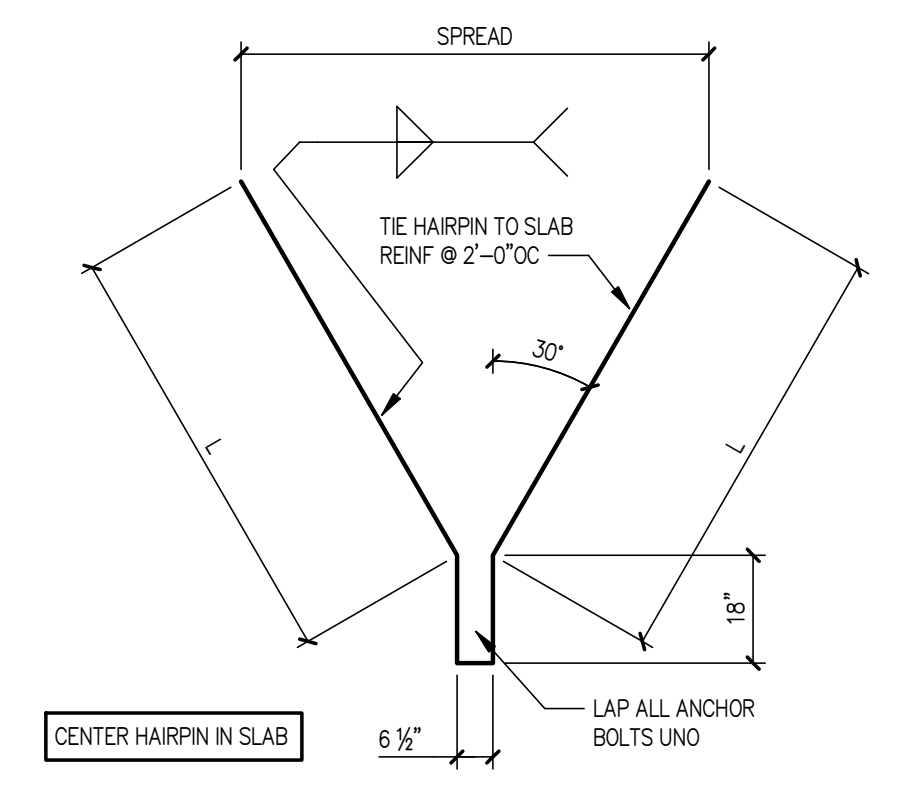

HAIRPIN SCHEDULE			
HAIRPIN MARK	SIZE	LENGTH (L)	TOTAL LENGTH PER HAIRPIN
HP1	#5	10'-0"	23'-6 1/2" (10'-8 1/2" SPREAD)
HP2	#6	15'-0"	33'-6 1/2" (15'-8 1/2" SPREAD)
HP3	#5	5'-0"	13'-6 1/2" (5'-8 1/2" SPREAD)

10 HAIRPIN DETAIL  
SCALE: 3/4" = 1'-0"

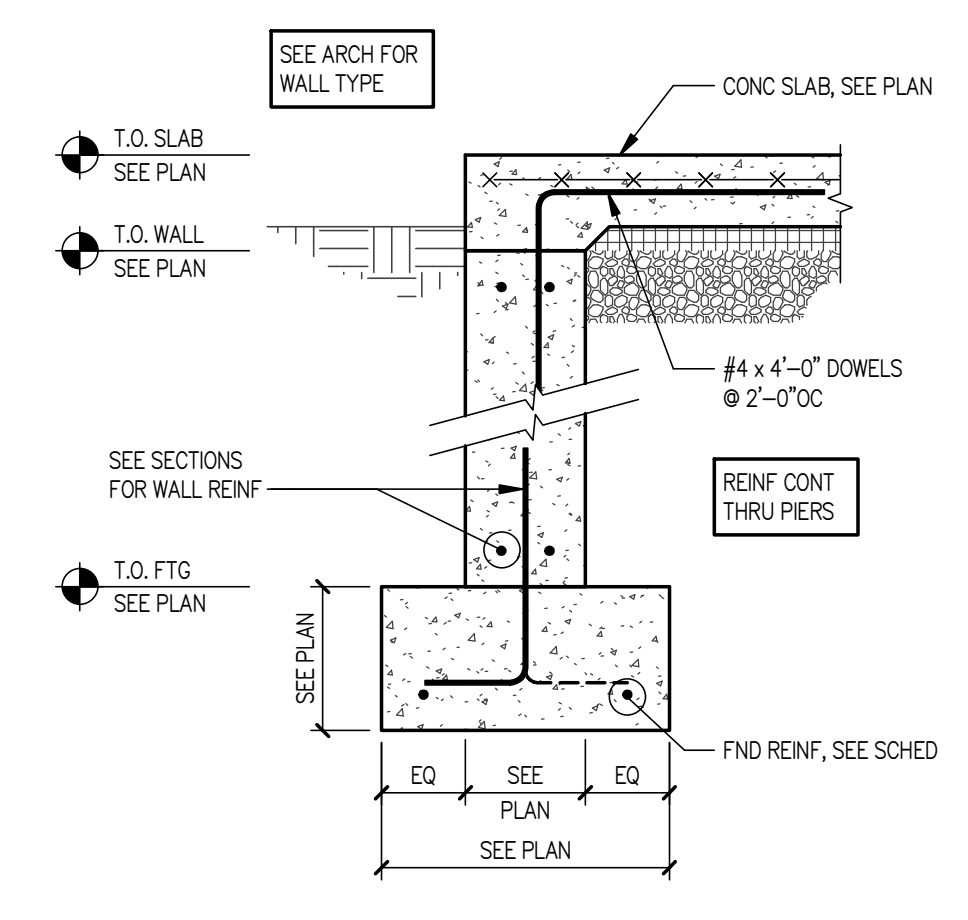

11 OH DOOR THRESHOLD  
SCALE: 3/4" = 1'-0"

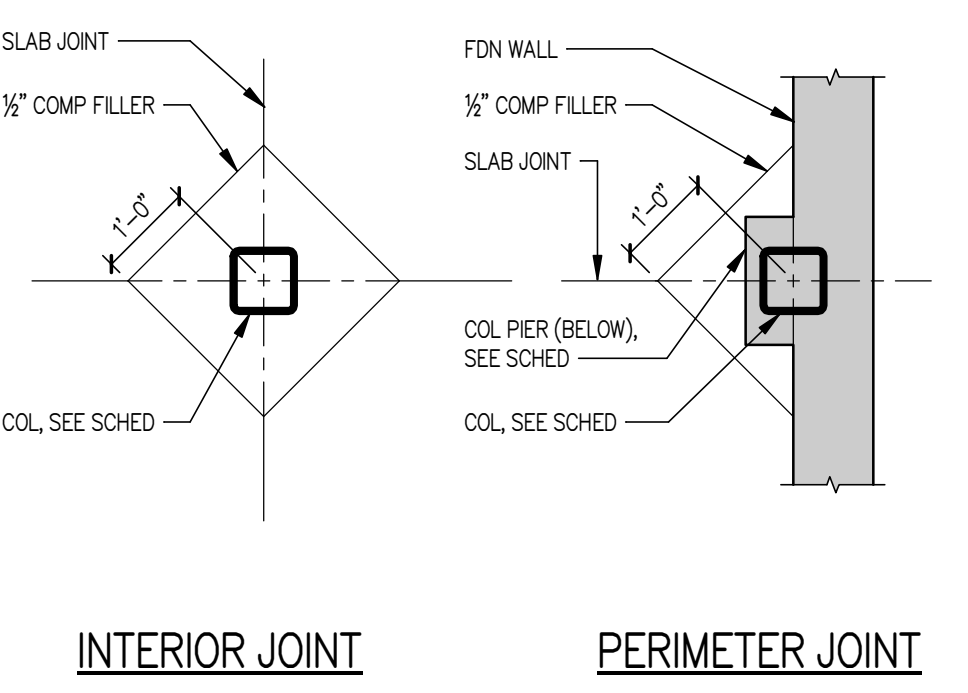

12 SLAB ISOLATION JOINT DETAILS  
SCALE: 1/2" = 1'-0"

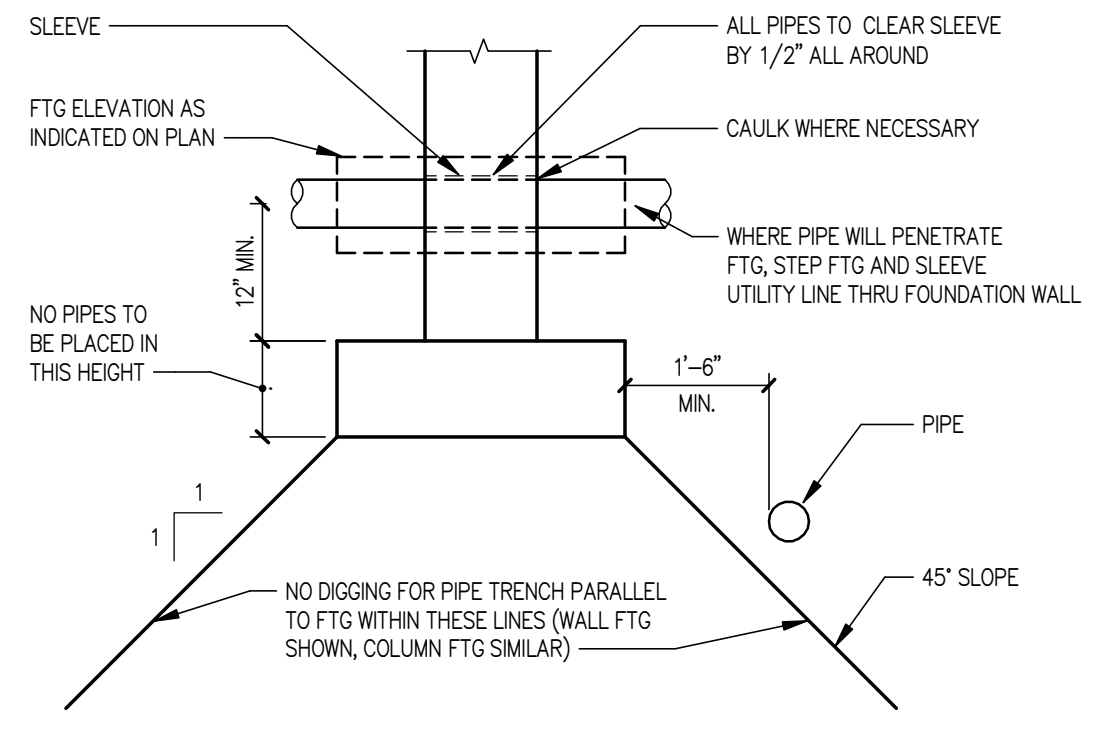

13 PIPE PENETRATION AT FDN WALL  
SCALE: NTS

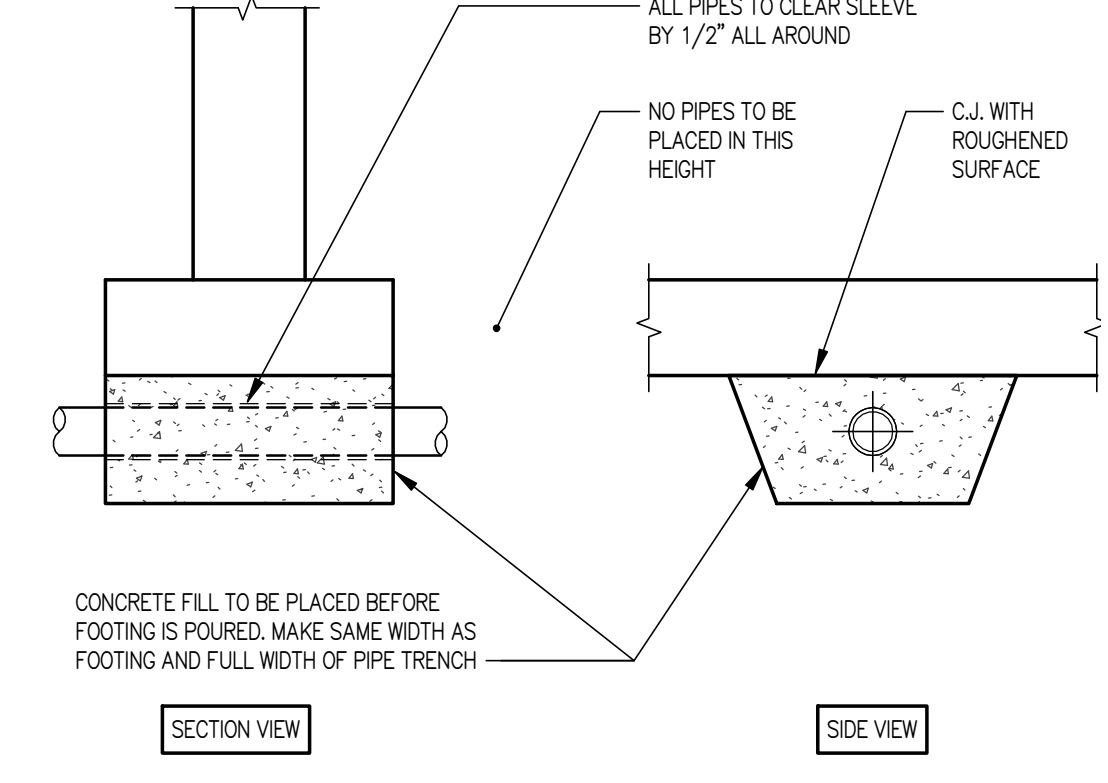

14 PIPE PENETRATION AT WALL FTG  
SCALE: NTS

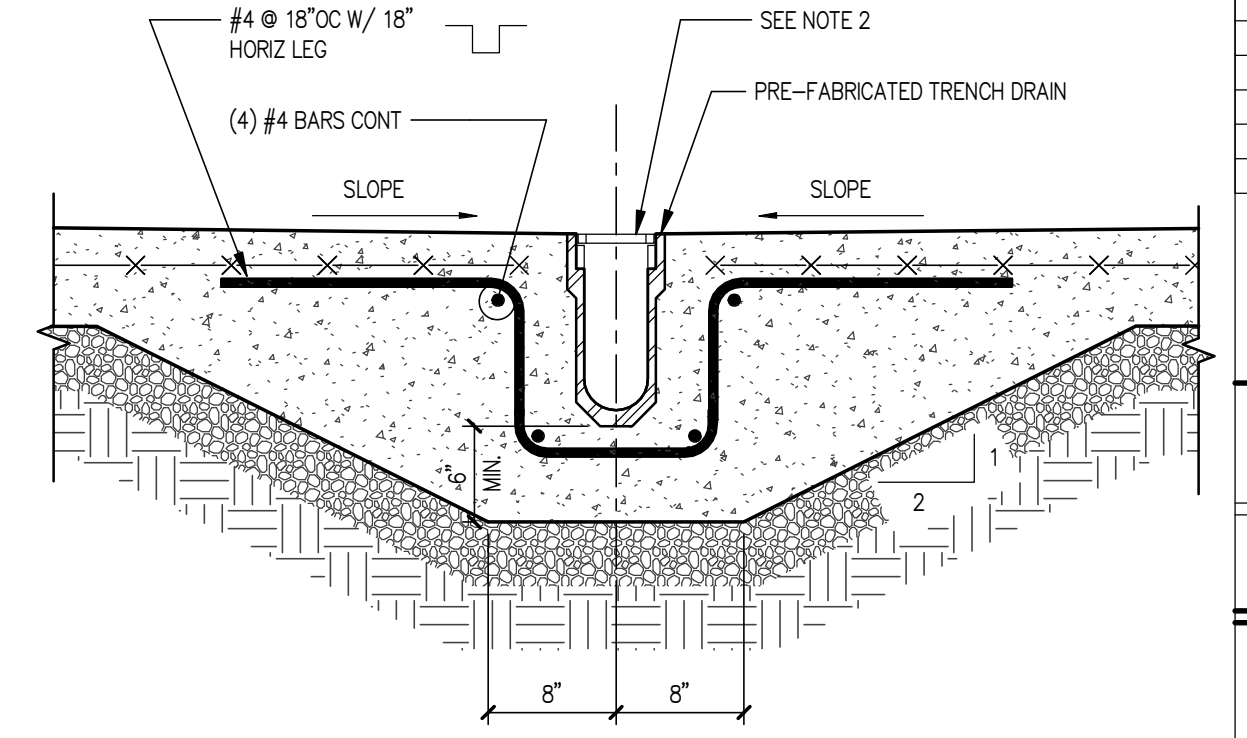

15 TRENCH DRAIN  
SCALE: 1" = 1'-0"

**BUILDING ADDITION**  
CITY OF EVANSVILLE  
535 S MADISON ST  
EVANSVILLE, WI

**Project Status**

NO.	DATE	DESCRIPTION
1	03.19.2021	FOR CONSTRUCTION

PROJ. #: 20001-01

© SKETCHWORKS ARCHITECTURE 2020

**CONCRETE DETAILS**

**S601**

**FOR CONSTRUCTION**

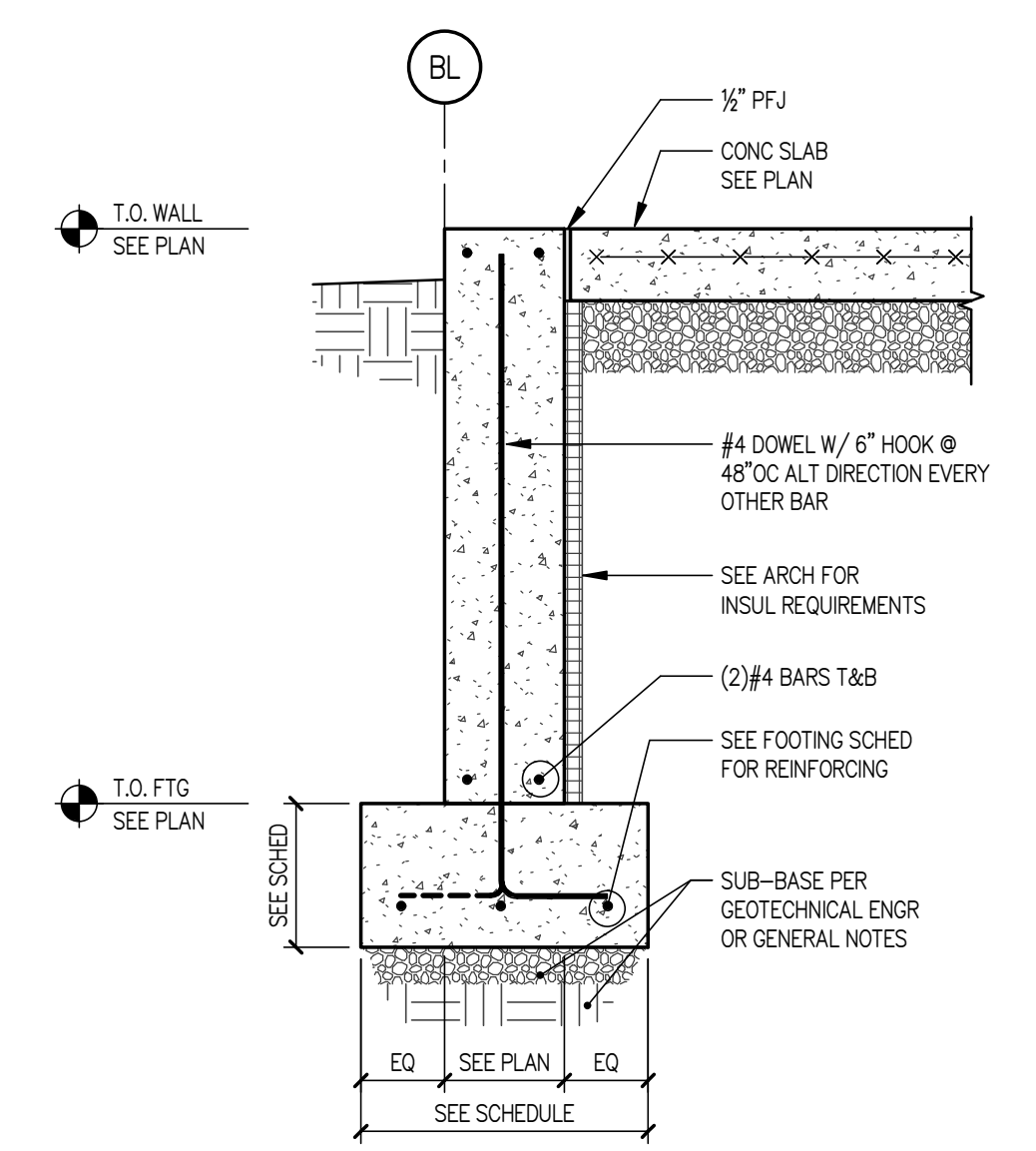

1 TYPICAL FOUNDATION WALL PEMB  
SCALE: 3/4" = 1'-0"

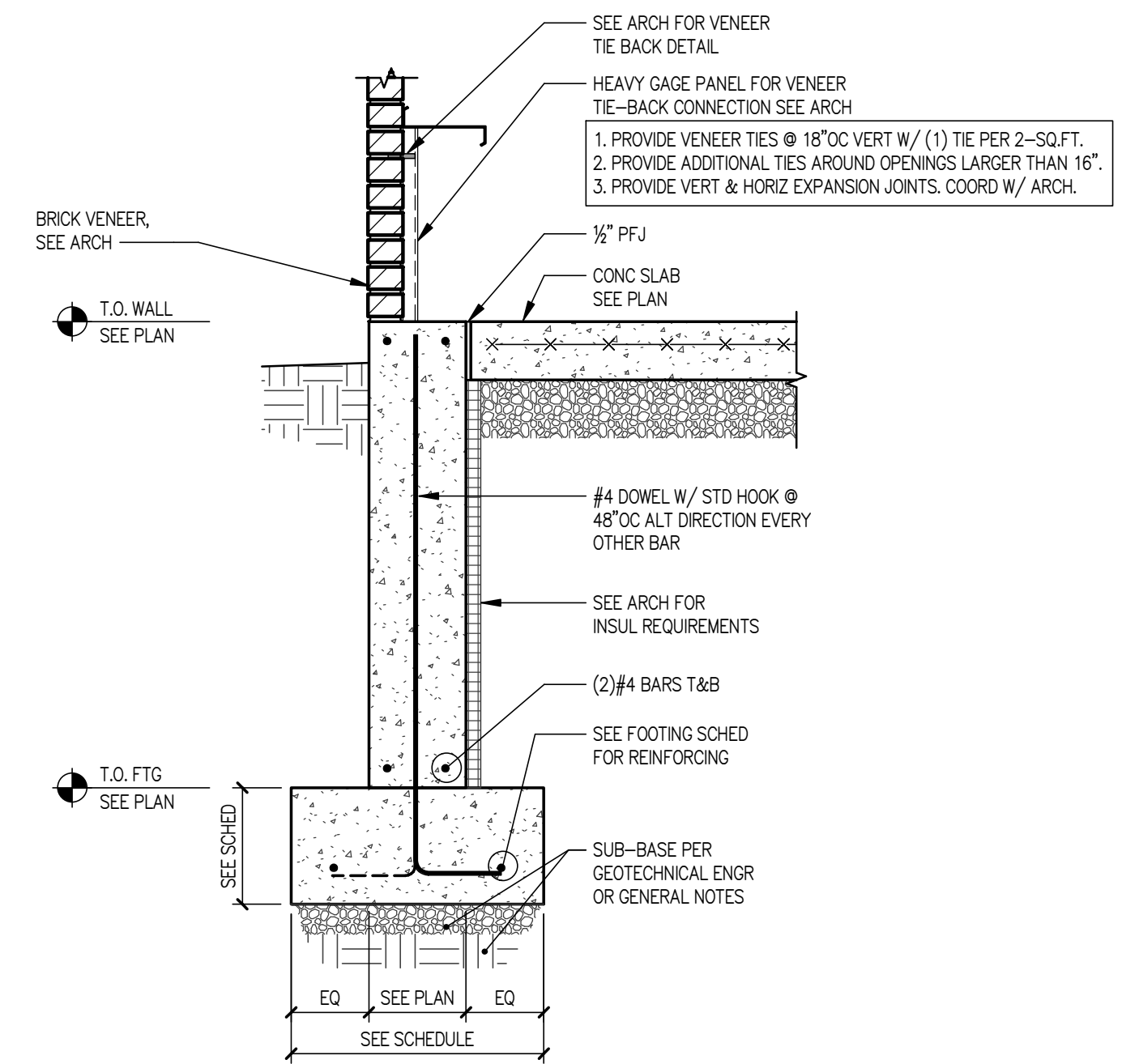

2 TYPICAL FOUNDATION WALL  
SCALE: 3/4" = 1'-0"

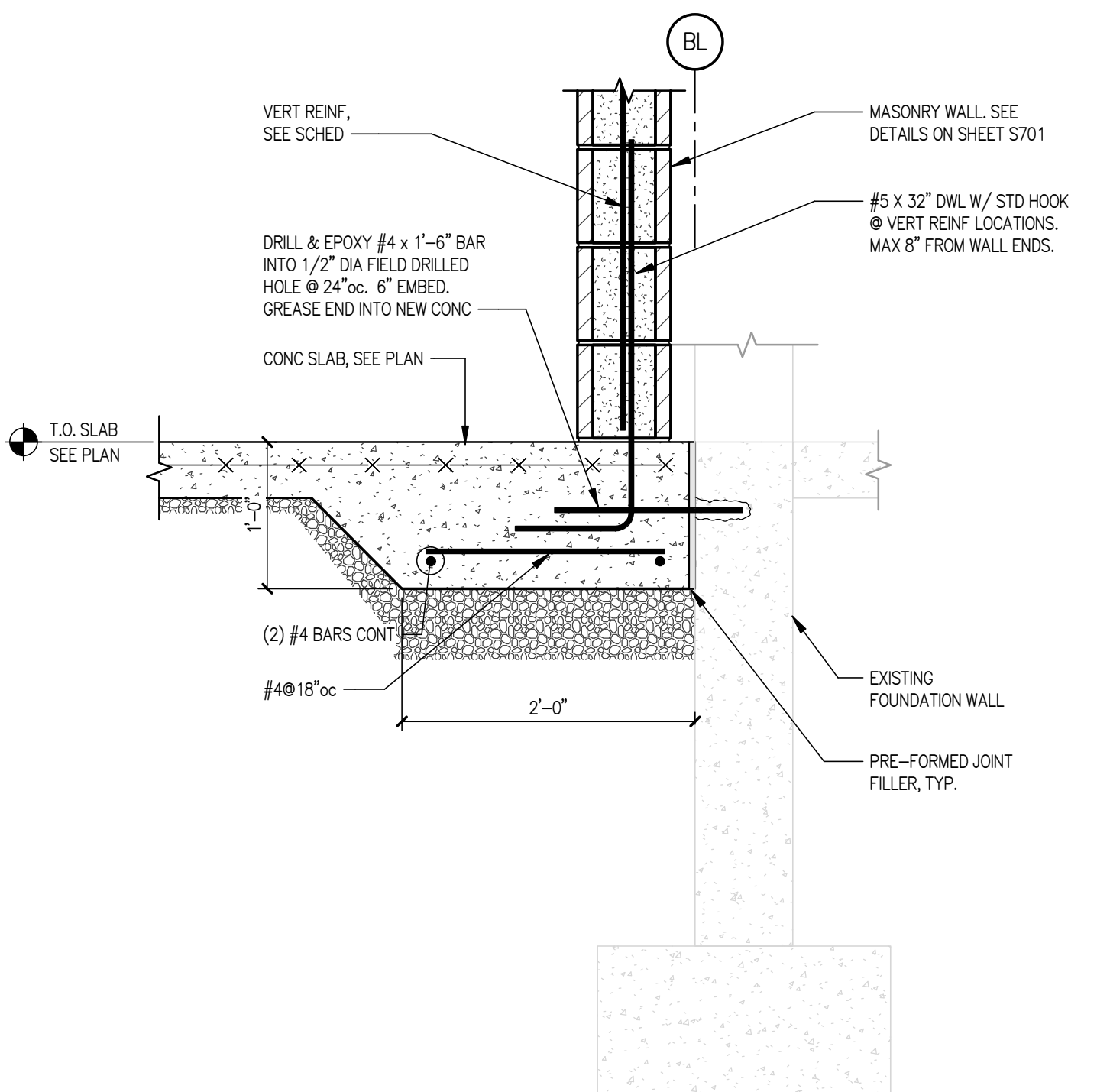

3 NEW SLAB TO EXISTING FDN WALL  
SCALE: 1" = 1'-0"

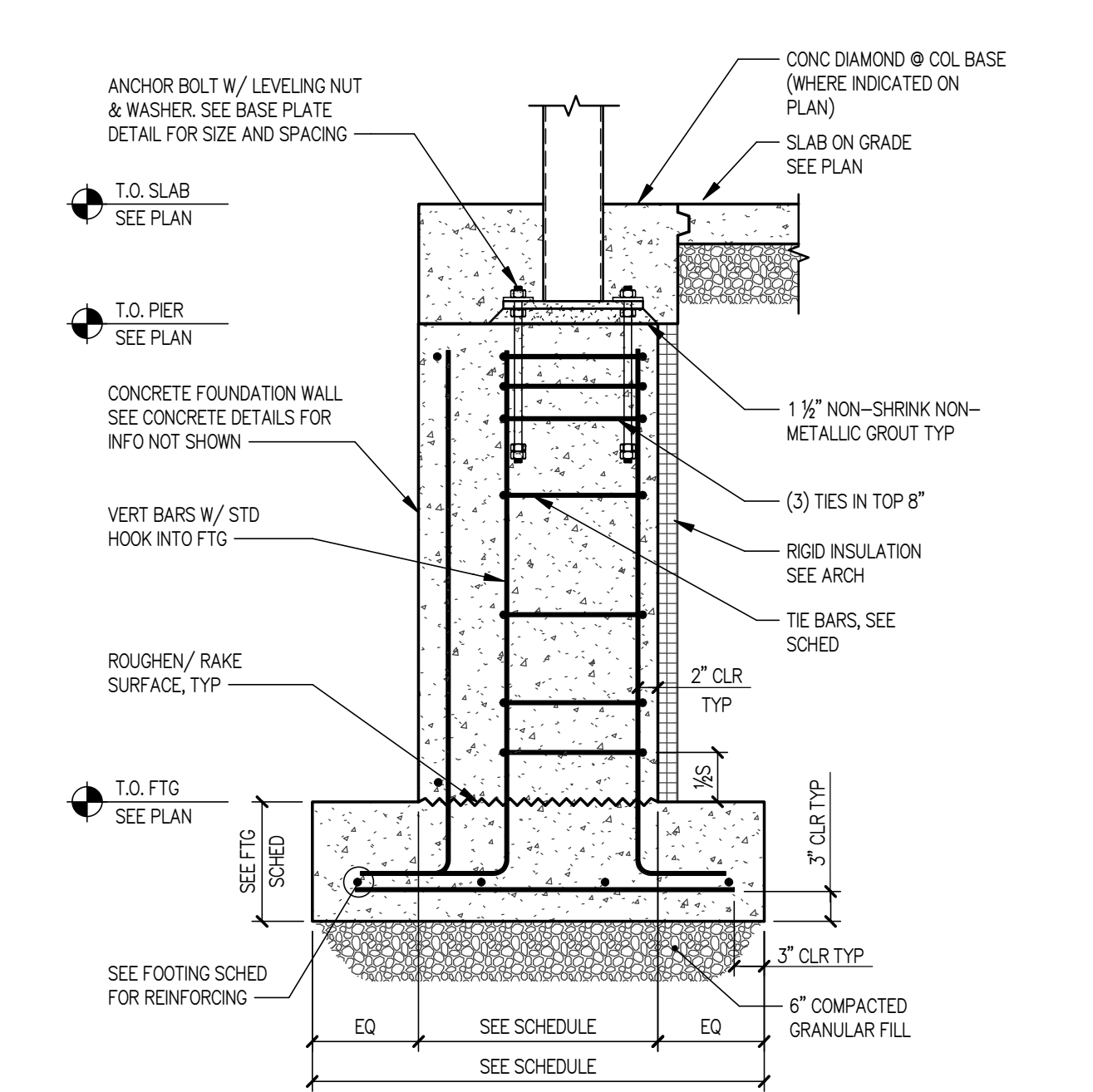

4 PIER SECTION  
SCALE: 3/4" = 1'-0"

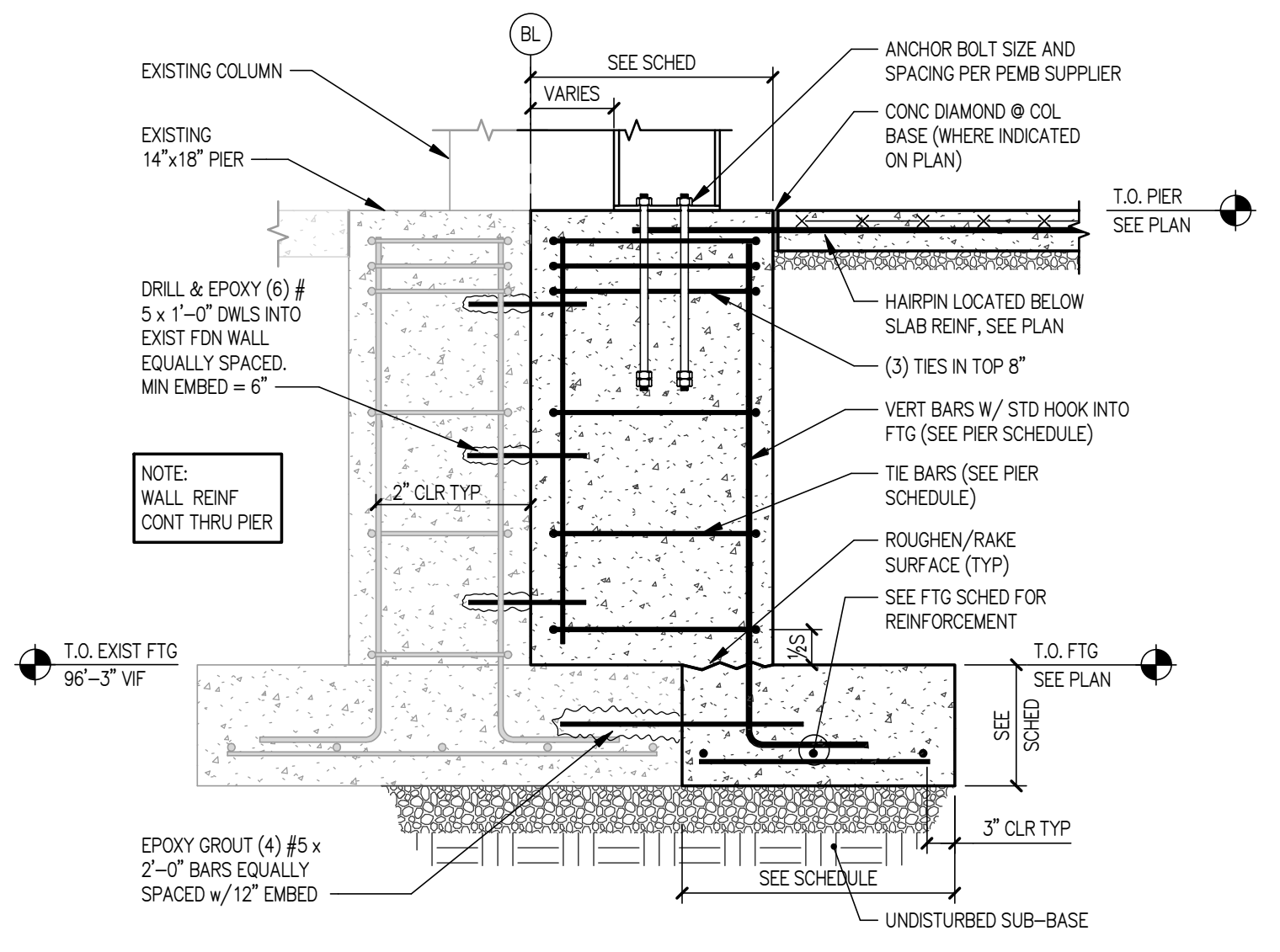

5 NEW PIER TO EXISTING PIER  
SCALE: 3/4" = 1'-0"

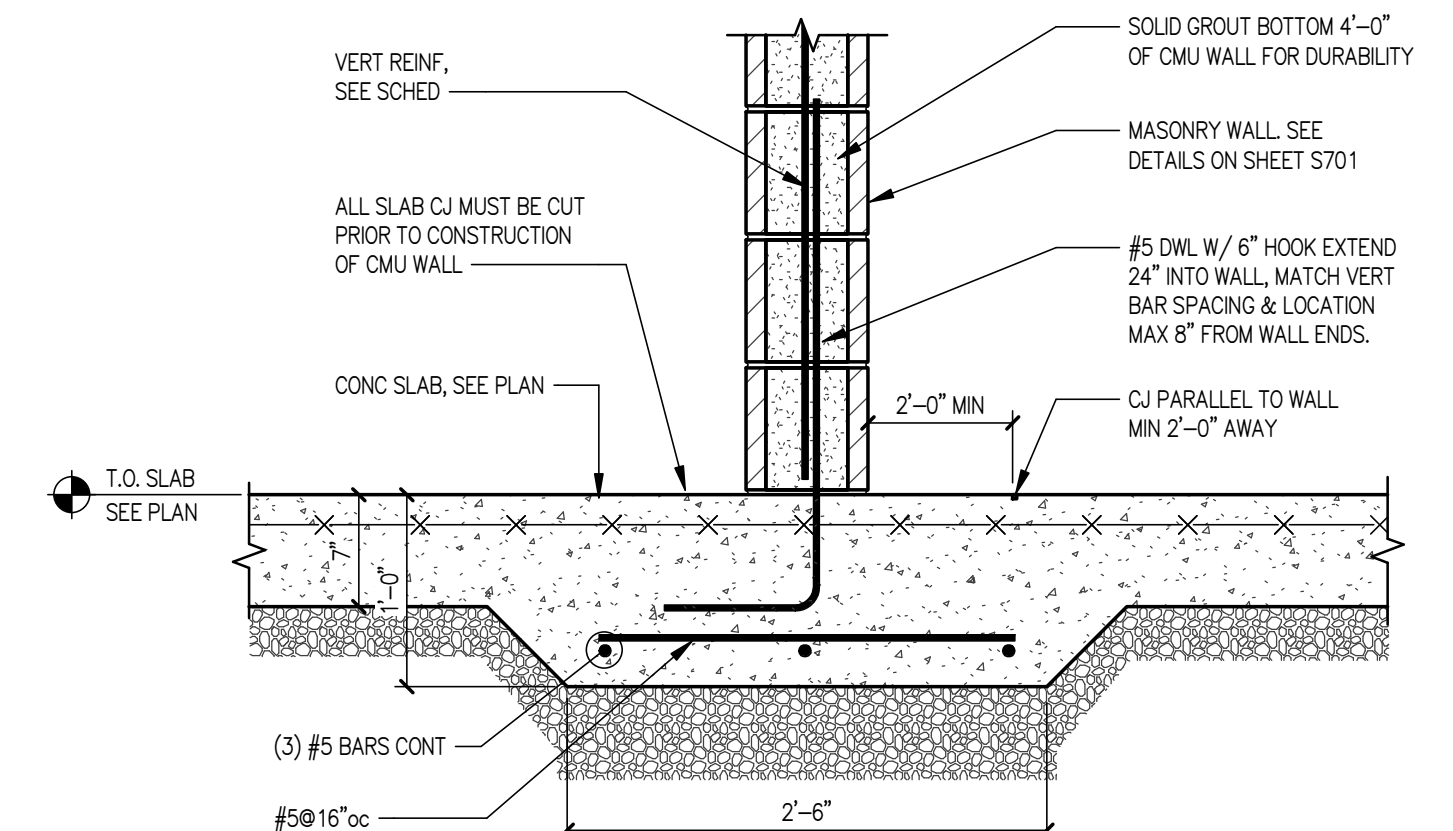

6 THICKENED SLAB AT INTERIOR CMU WALL  
SCALE: 1" = 1'-0"

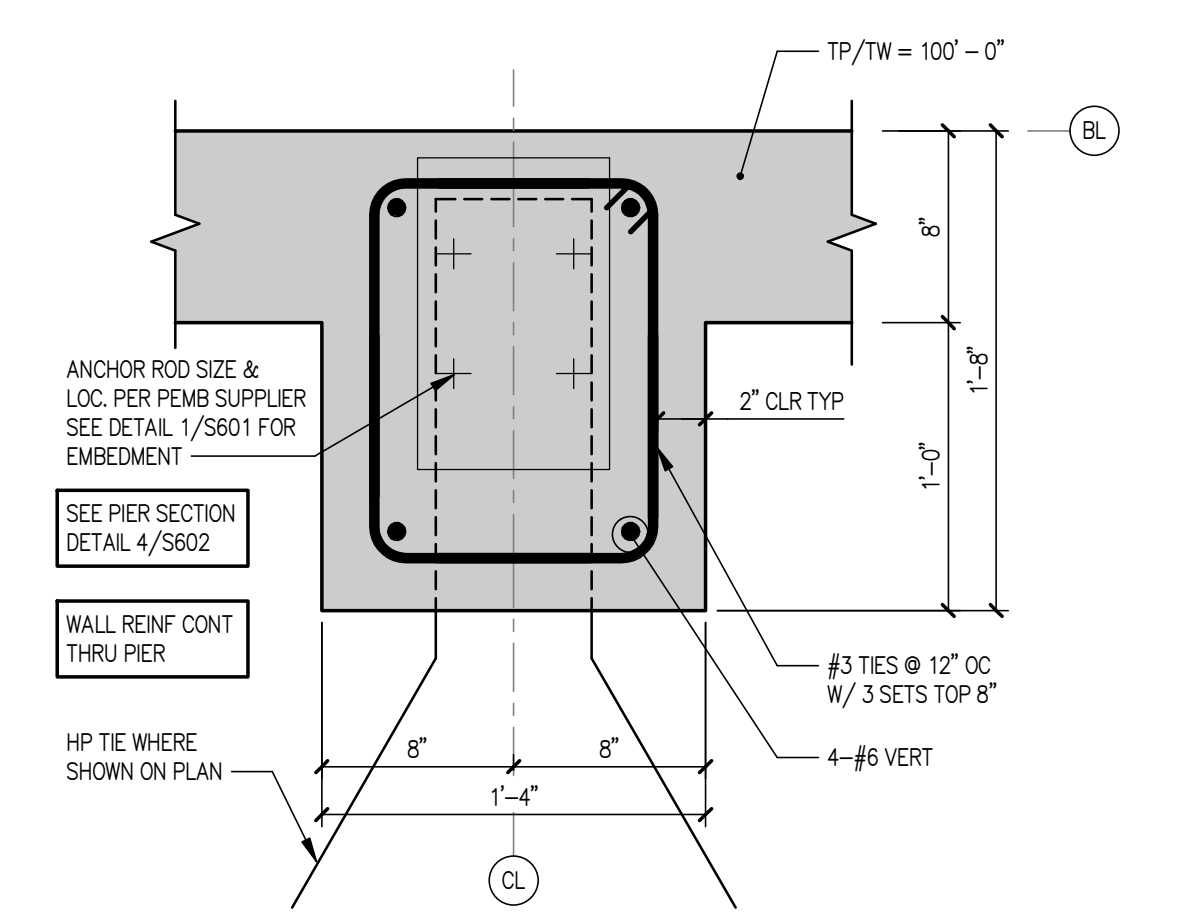

7 PIER P1 DETAIL  
SCALE: 1 1/2" = 1'-0"

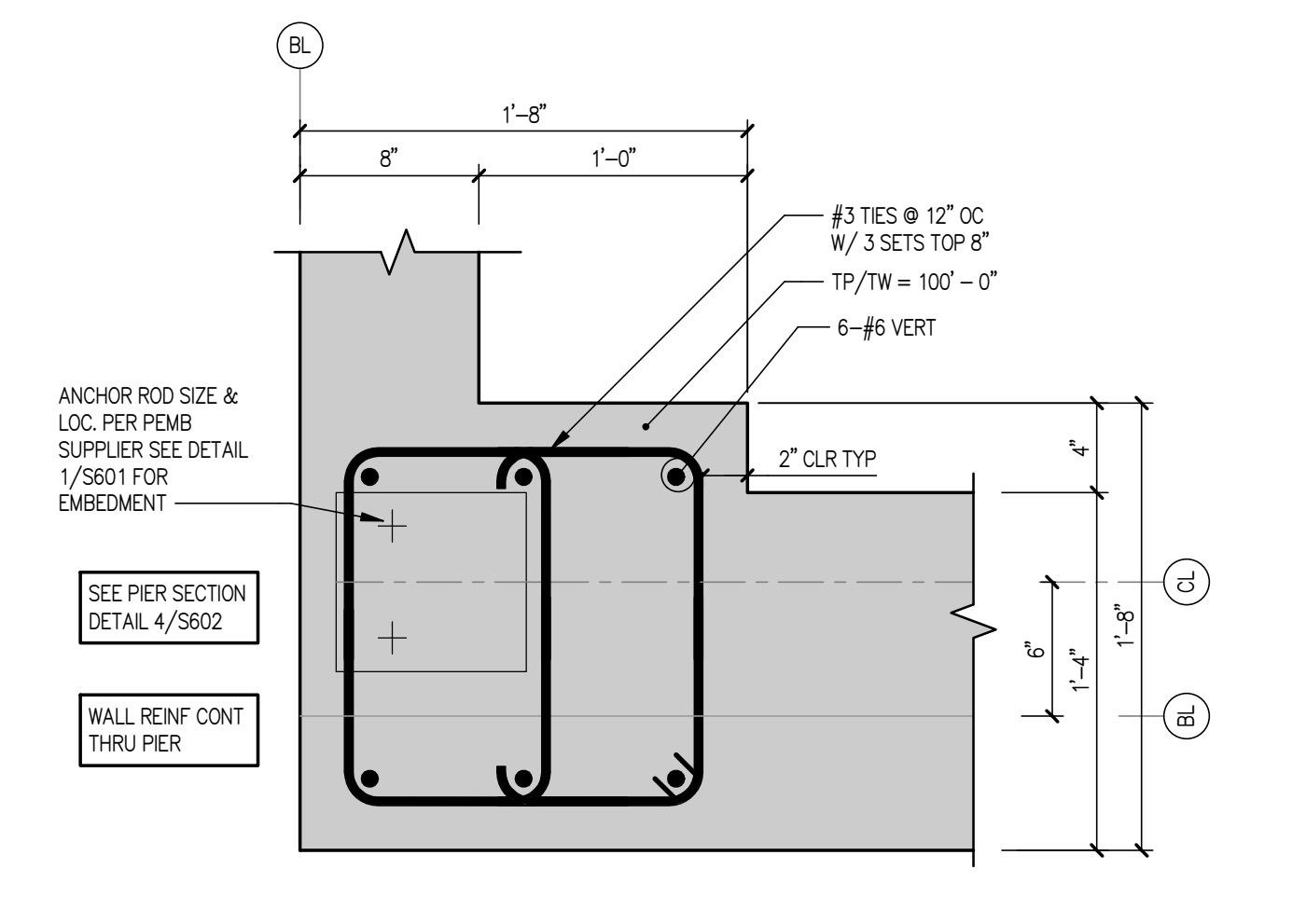

8 PIER P2 DETAIL  
SCALE: 1 1/2" = 1'-0"

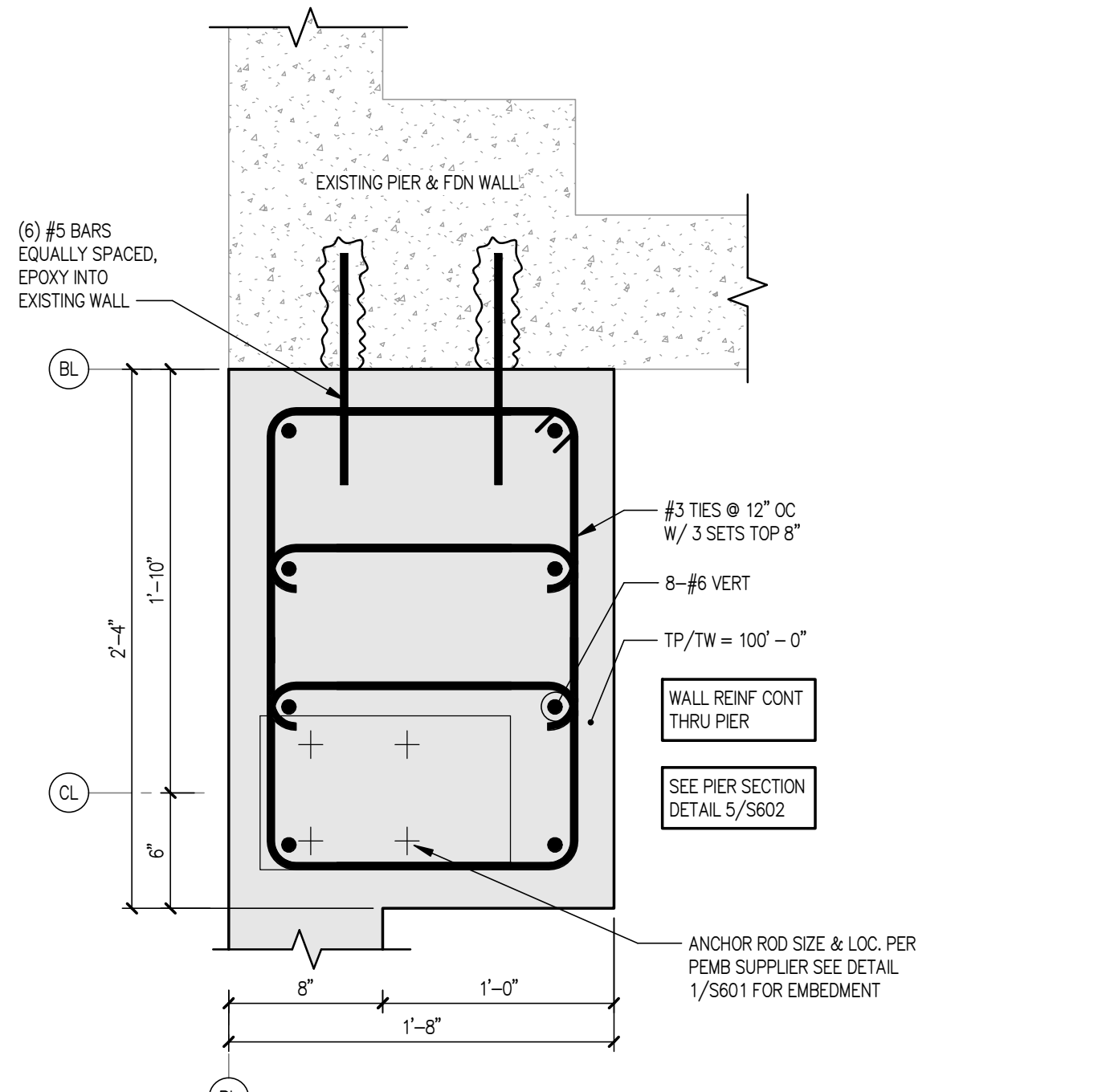

9 PIER P3 DETAIL  
SCALE: 1 1/2" = 1'-0"

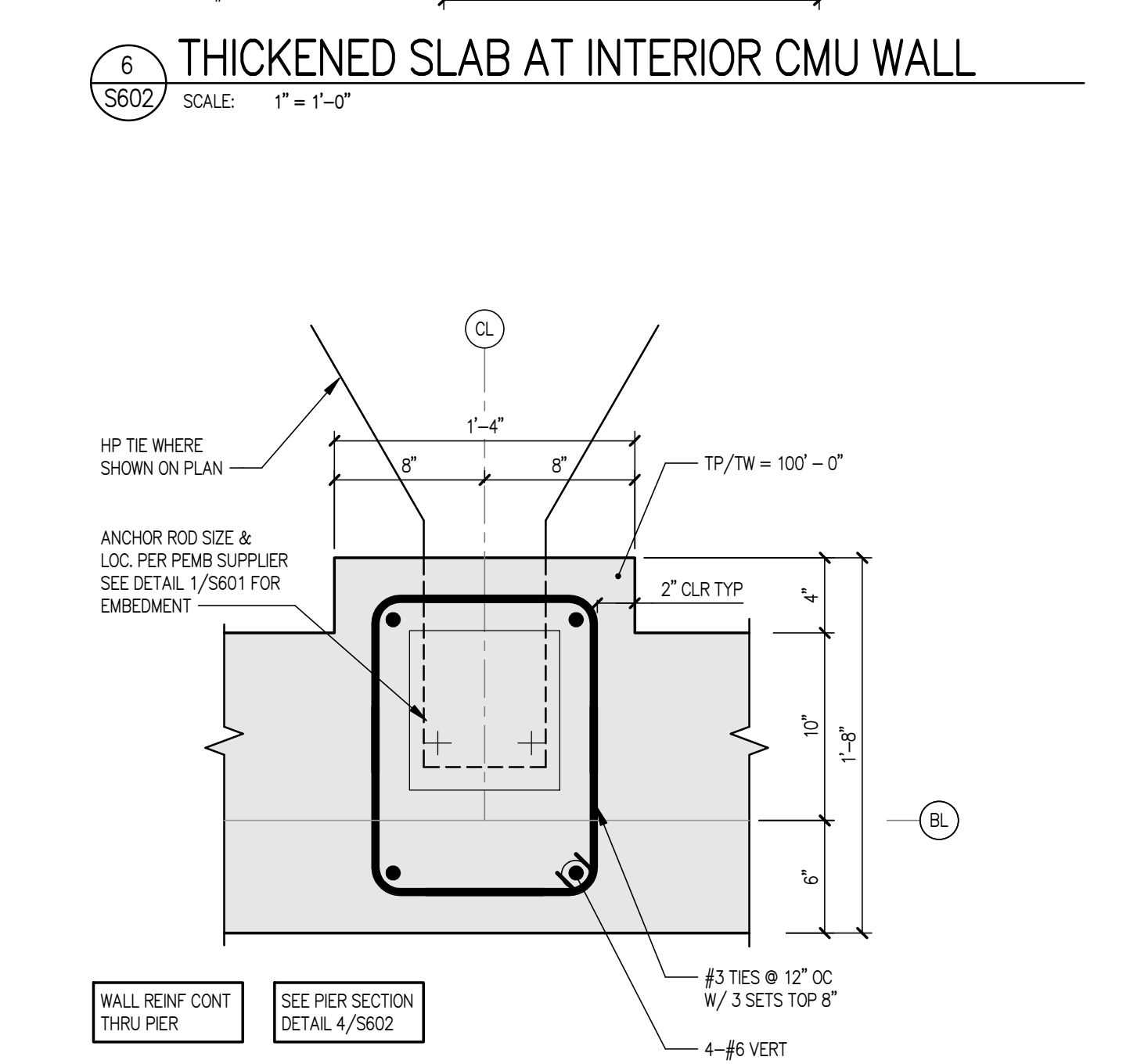

10 PIER P4 DETAIL  
SCALE: 1 1/2" = 1'-0"

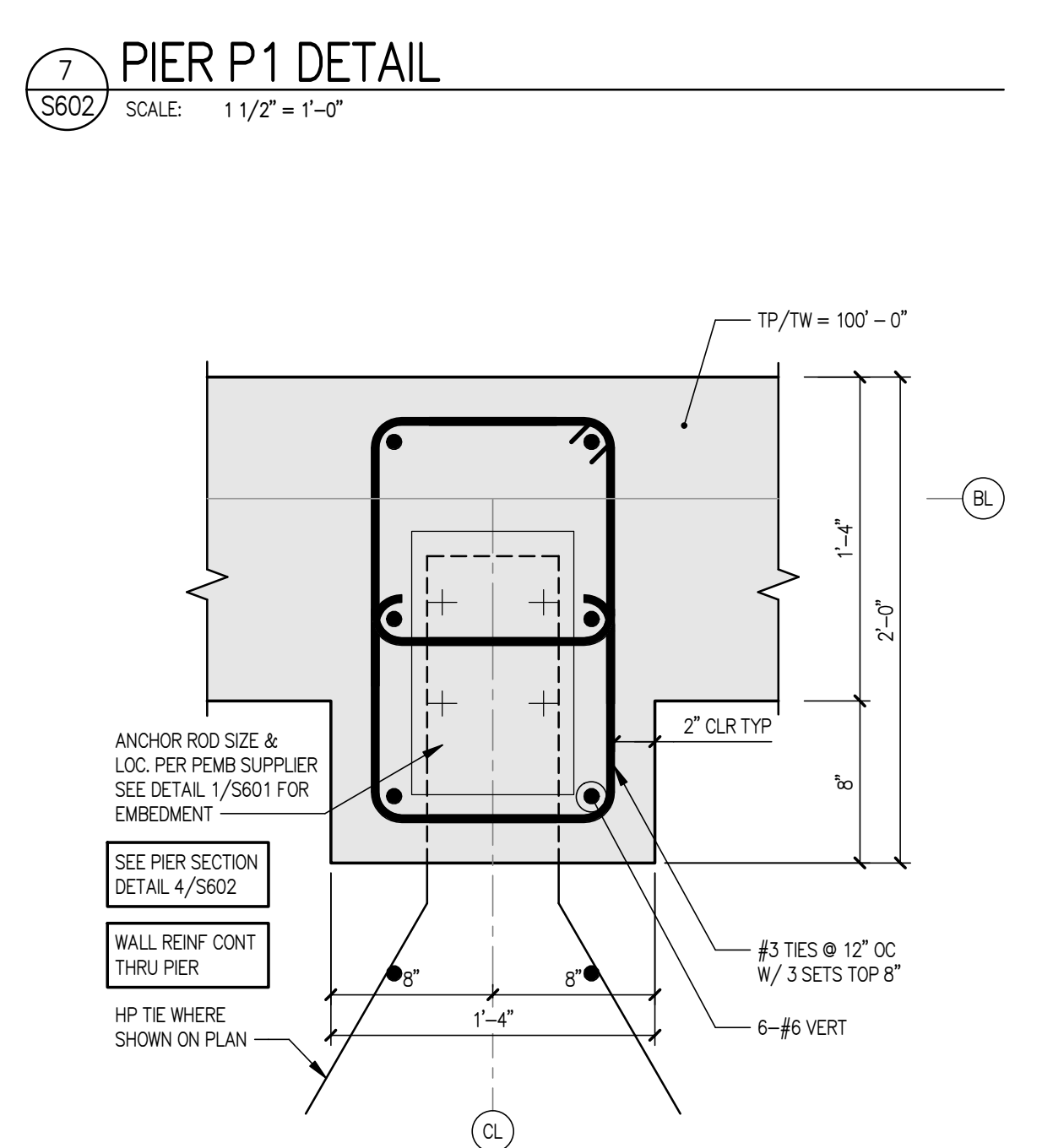

11 PIER P5 DETAIL  
SCALE: 1 1/2" = 1'-0"

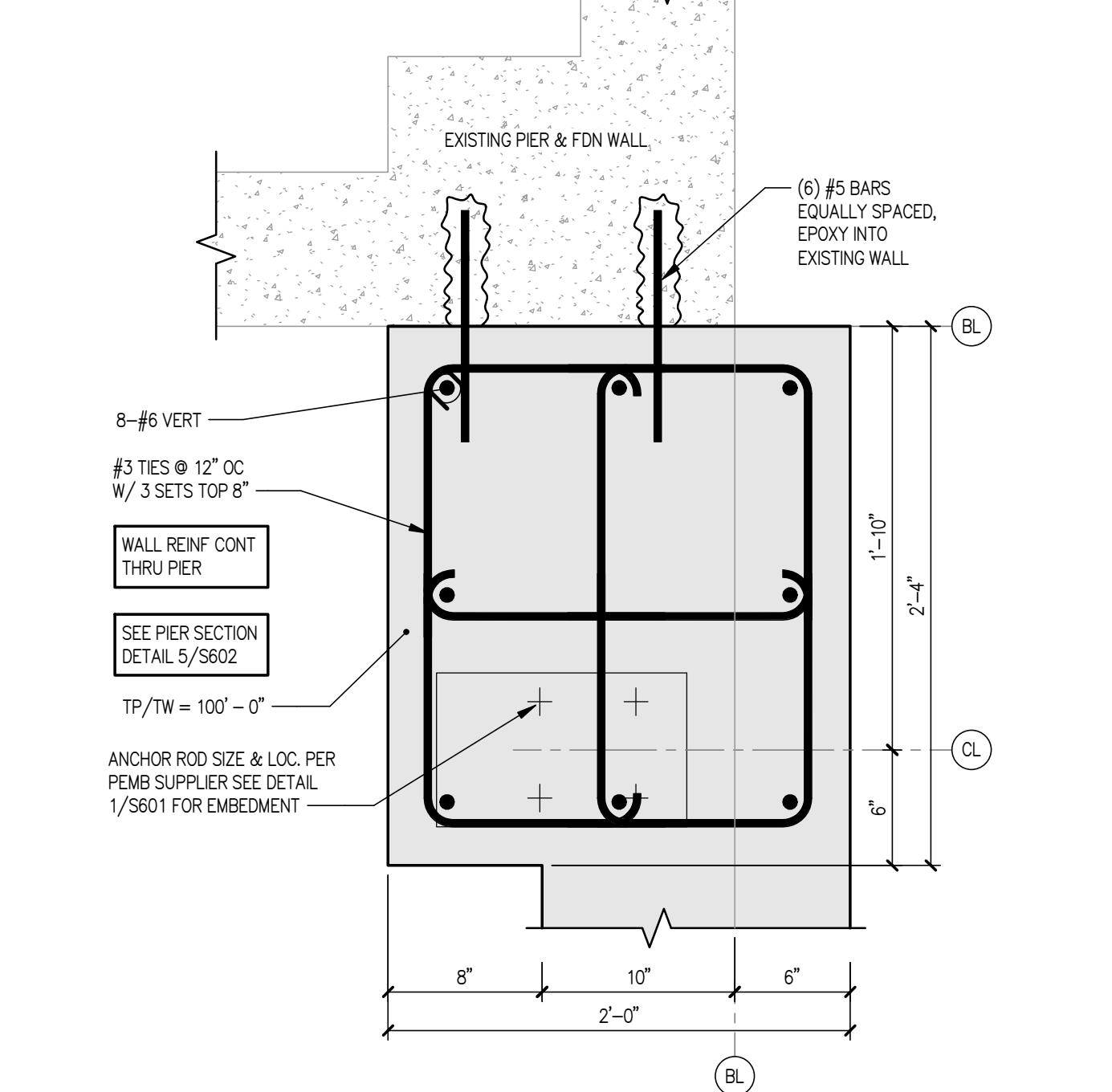

12 PIER P6 DETAIL  
SCALE: 1 1/2" = 1'-0"

**BUILDING ADDITION**  
CITY OF EVANSVILLE  
535 S MADISON ST  
EVANSVILLE, WI

**Project Status**

NO.	DATE	DESCRIPTION
1	03.19.2021	FOR CONSTRUCTION

PROJ. #: 20001-01

© SKETCHWORKS ARCHITECTURE 2020

**CONCRETE DETAILS**

**S602**

**FOR CONSTRUCTION**

D  
C  
B  
A

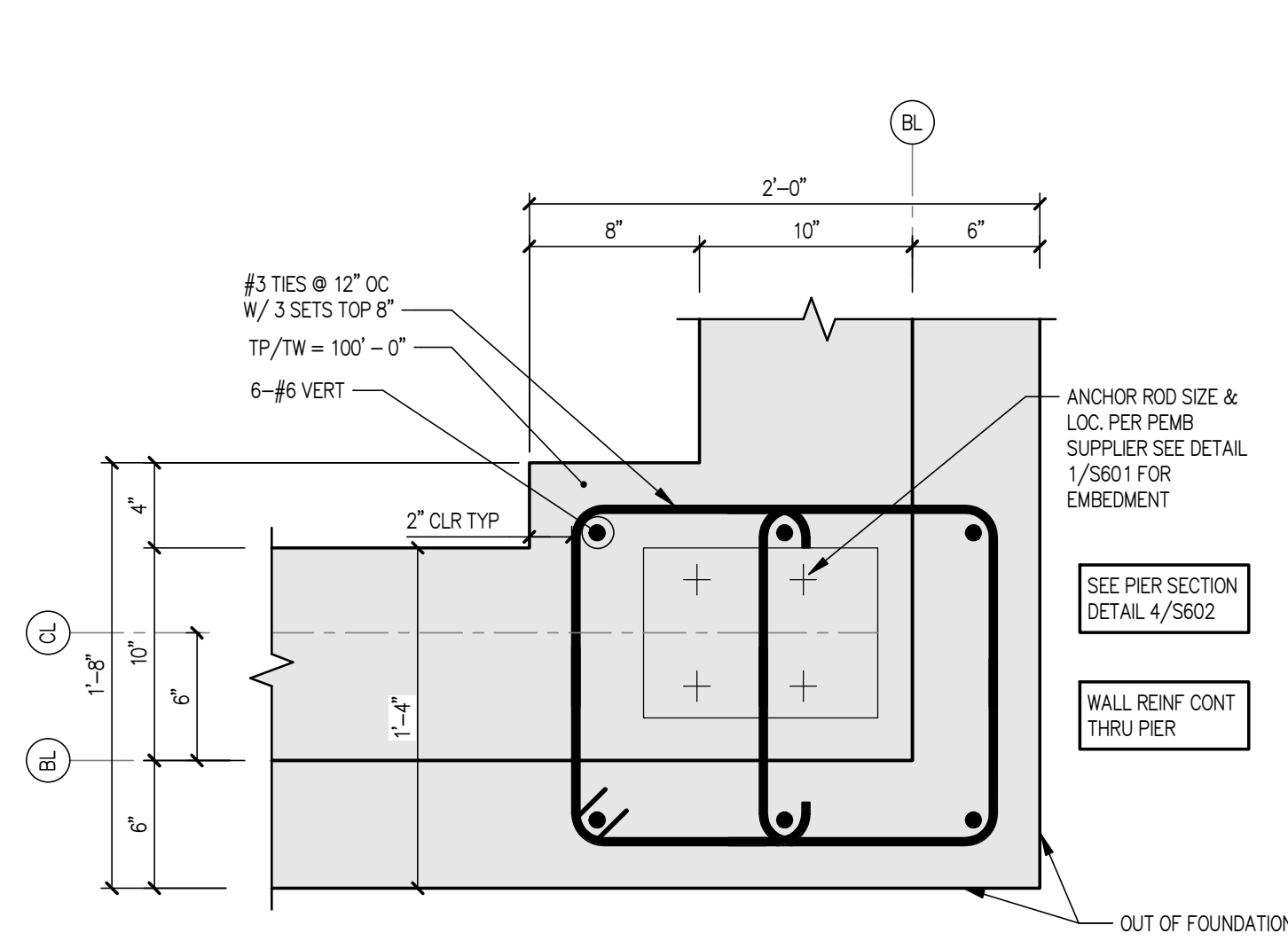

1 PIER P7 DETAIL  
SCALE: 1 1/2" = 1'-0"

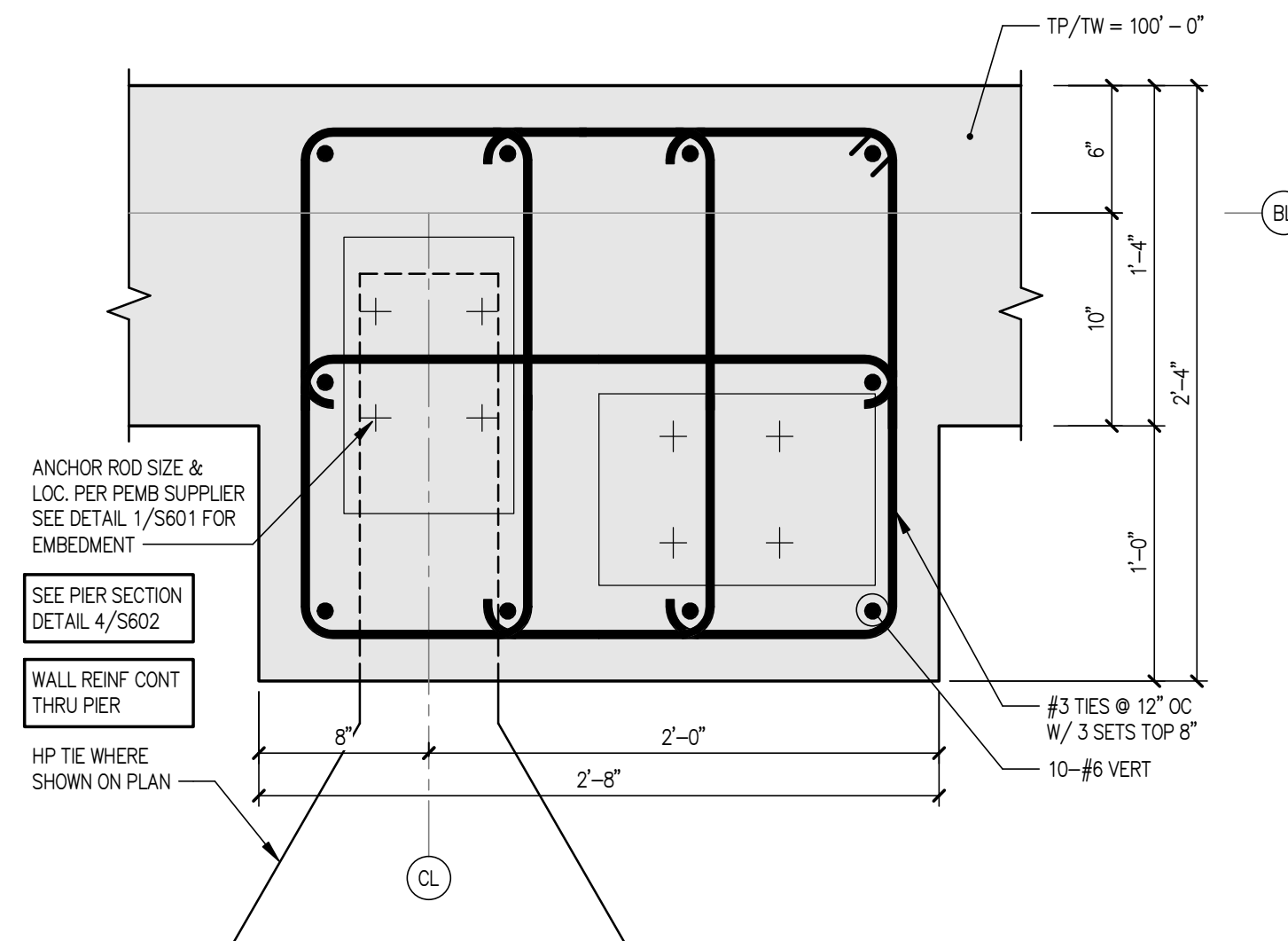

2 PIER P8 DETAIL  
SCALE: 1 1/2" = 1'-0"

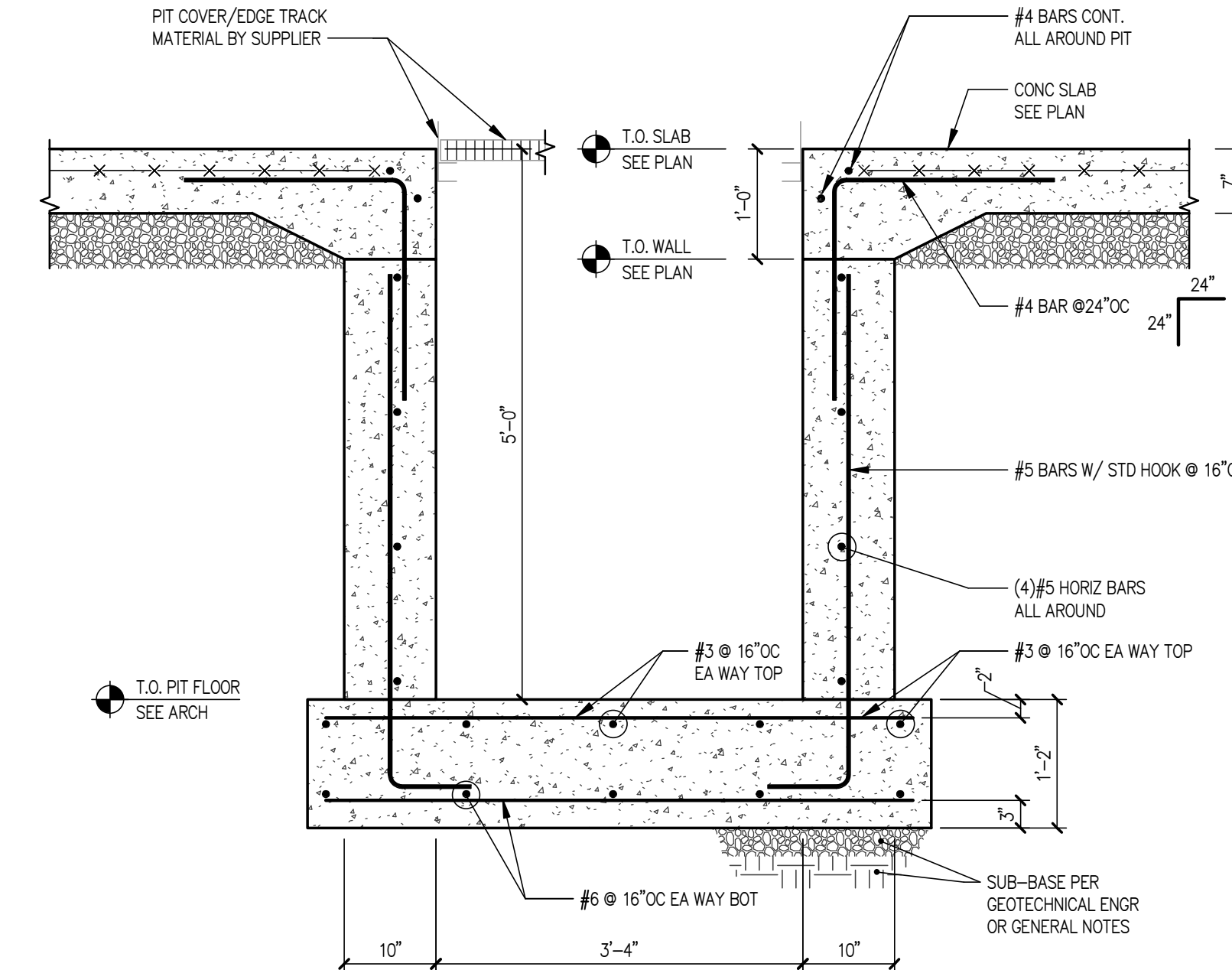

3 SECTION AT MAINTENANCE PIT  
SCALE: 3/4" = 1'-0"

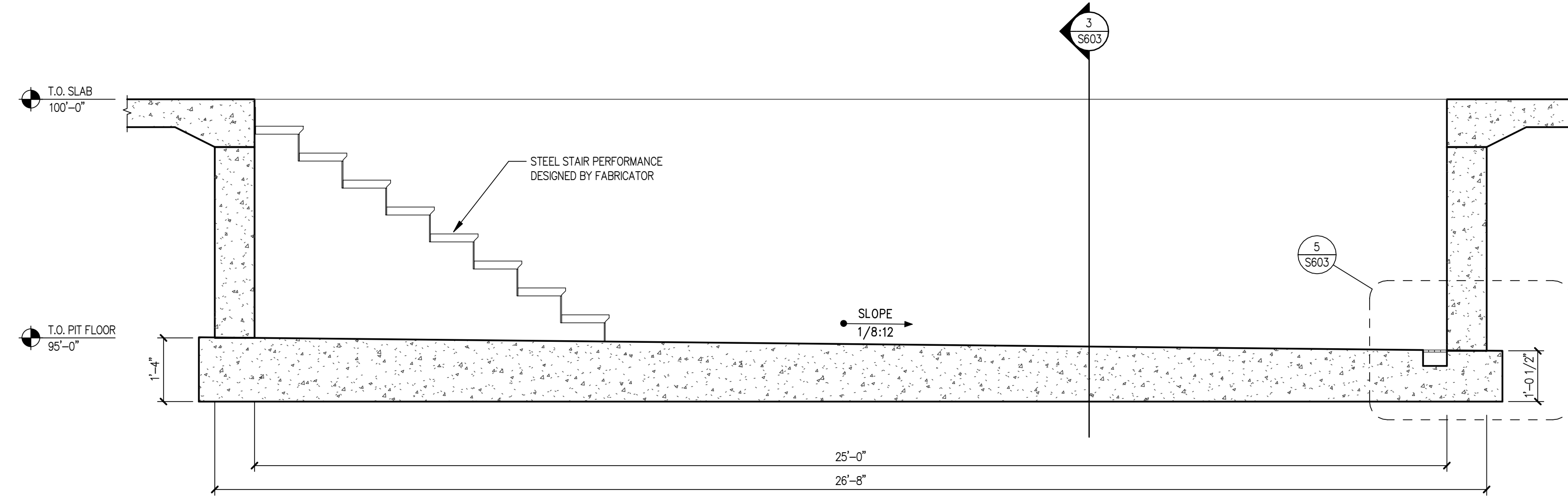

4 MAINTENANCE PIT SECTION  
SCALE: 1/2" = 1'-0"

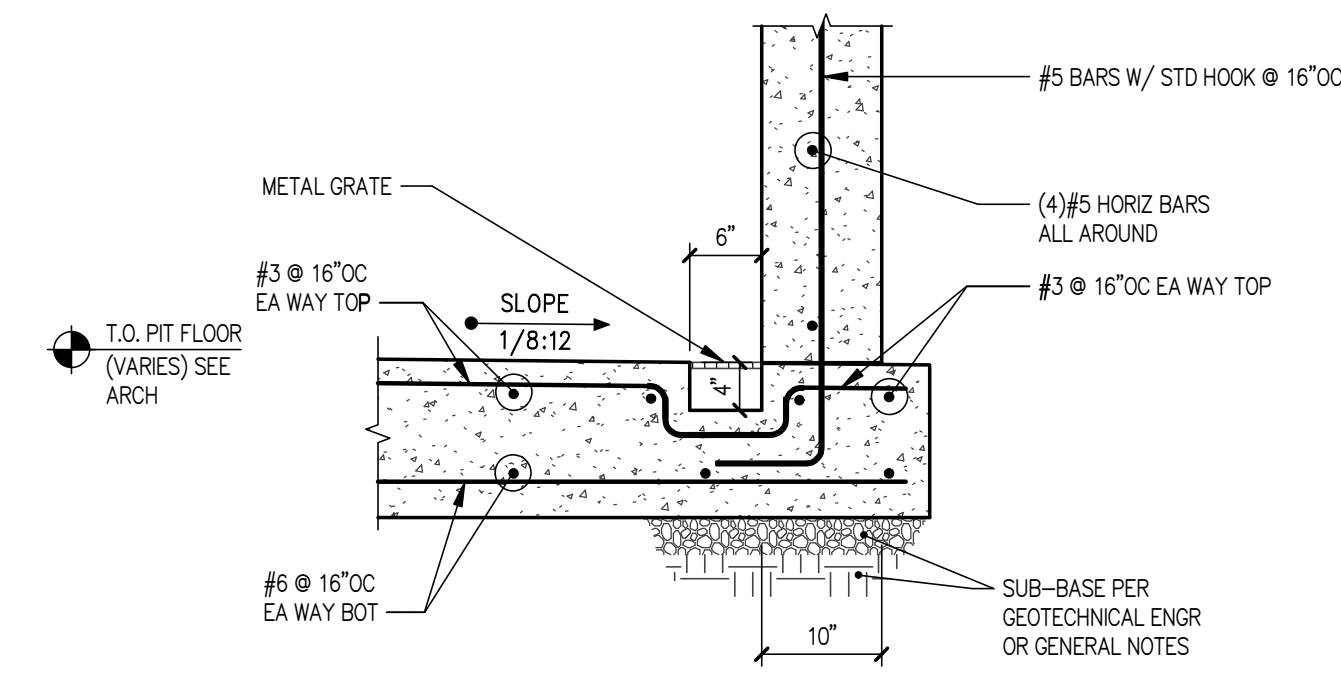

5 SECTION AT MAINTENANCE PIT FLOOR DRAIN  
SCALE: 3/4" = 1'-0"

**BUILDING ADDITION**  
CITY OF EVANSVILLE  
535 S MADISON ST  
EVANSVILLE, WI

**Project Status**

ID	DATE	DESCRIPTION
1	03.19.2021	FOR CONSTRUCTION

PROJ. #: 20001-01

© SKETCHWORKS ARCHITECTURE 2020

**CONCRETE DETAILS**

**S603**



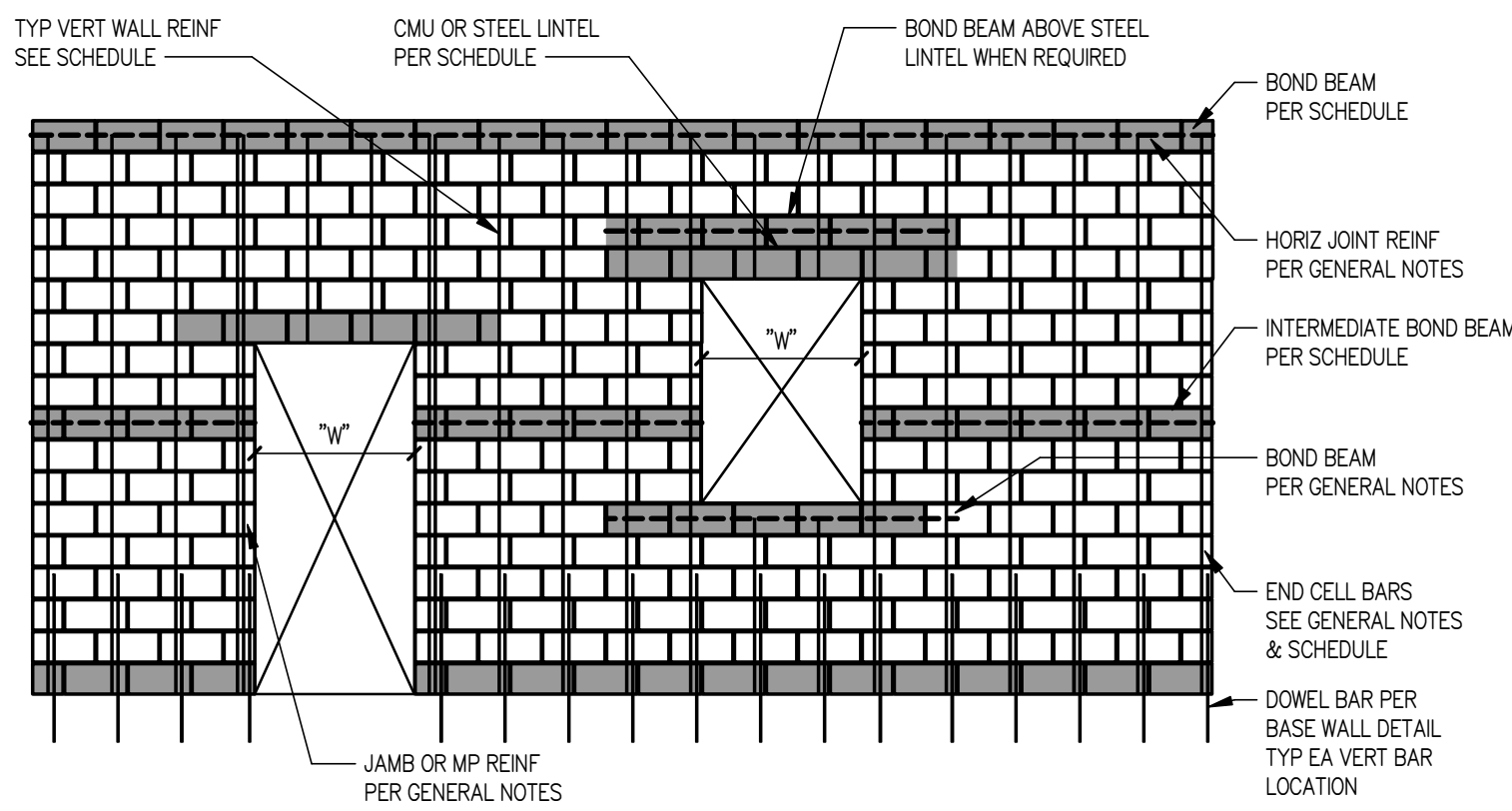

WALL MARK	TYPE	BAR SIZE & SPACING	BOND BEAM SPACING	BOND BEAM REINFORCING	REMARKS
MW1 8"	B	#5@16"OC	VARIES SEE REMARKS	(2)#4	BOND BEAM @ 8" OC AND TOP OF WALL (GROUT BOTTOM 4"-0" OF WALL SOLID)

1. READ ALL MASONRY NOTES ON SHEET S001
2. LINTELS AND BOND BEAMS ARE REQUIRED ABOVE AND/OR BELOW ANY OPENINGS EXCEEDING 8" IN EITHER DIMENSION. THIS INCLUDES, BUT IS NOT LIMITED TO MECHANICAL, ELECTRICAL, PLUMBING, DOOR OR WINDOW OPENINGS.
3. PROVIDE BOND BEAM AT ALL JOIST BEARING & TOP OF PARAPET ELEVATIONS & AS NOTED IN SCHEDULE
4. GROUT SOLID W/ (1)#5 UNDER LINTEL BEARING (UNO) AND PROVIDE (1)#5 BAR FULL HEIGHT AT EACH SIDE OF OPENINGS, DOORS, WINDOWS & DUCT OPENINGS LESS THAN 6'-0" WIDE, & (2)#5 BARS FULL HEIGHT AT OPENINGS GREATER THAN 6'-0" @ MASONRY PIER PER PLAN.
5. PROVIDE HORIZONTAL JOINT REINFORCEMENT @ 16"OC MAXIMUM, VERTICALLY FOR THE FULL WALL HEIGHT, TYPICAL ALL RUNNING BOND WALLS.
6. "SW" INDICATES SHEAR WALL LOCATIONS. PROVIDE FULL TENSION SPLICE OF MP TO FOUNDATION AT EACH END OF WALL SEGMENT.

### 1 CMU WALL SCHEDULE

S701 SCALE: NTS

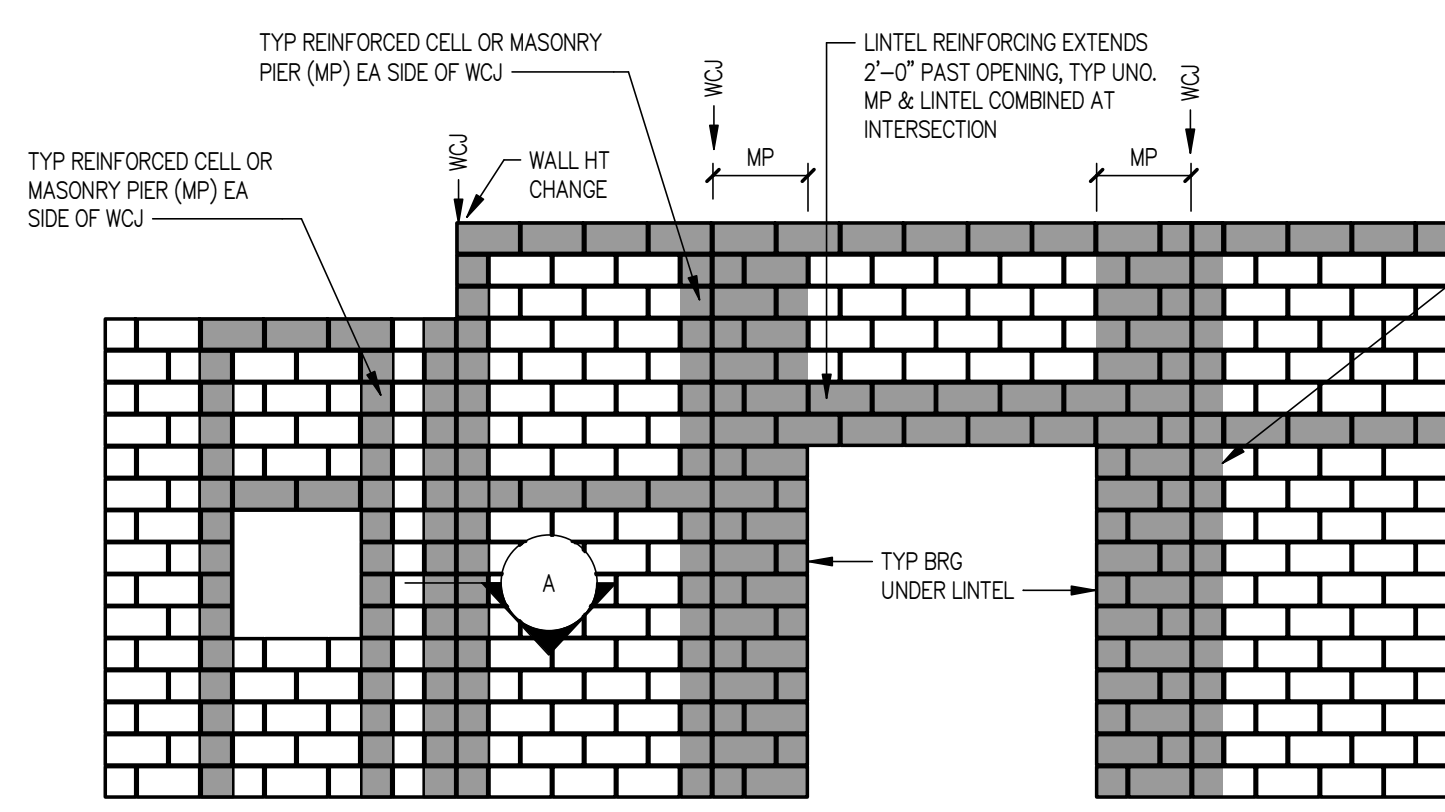

CMU CONTROL JOINT SPACING (MOISTURE CONTROLLED CONCRETE MASONRY UNITS)	
SUGGESTED SPACING OF CONTROL JOINTS	VERTICAL SPACING OF JOINT REINFORCEMENT = 16" TYP
EXTERIOR WALL DISTANCE FROM CORNER	12' TO 15'
EXTERIOR WALL CONTINUOUS SPAN	24' TO 30'
INTERIOR WALL CONTINUOUS SPAN ≤ 30'	N/A
WALL HEIGHT CHANGE	N/A

1. LOCATE CJ PER SCHEDULE UNO ON PLAN OR ARCH DRAWINGS.

### 2 CMU CONTROL JOINT SCHEDULE (MASONRY LINTEL SHOWN)

S701 SCALE: NTS

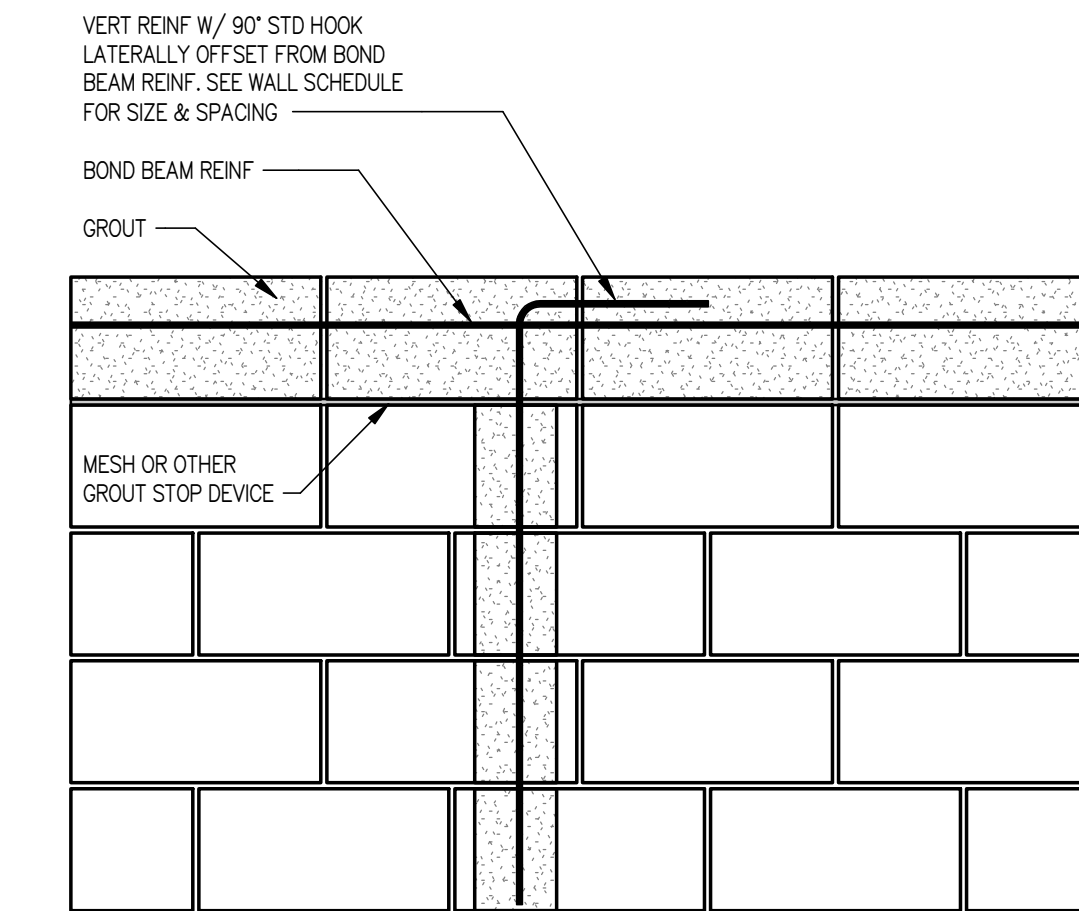

### 6 VERTICAL REIN AT TOP OF WALL

S701 SCALE: 1" = 1'-0"

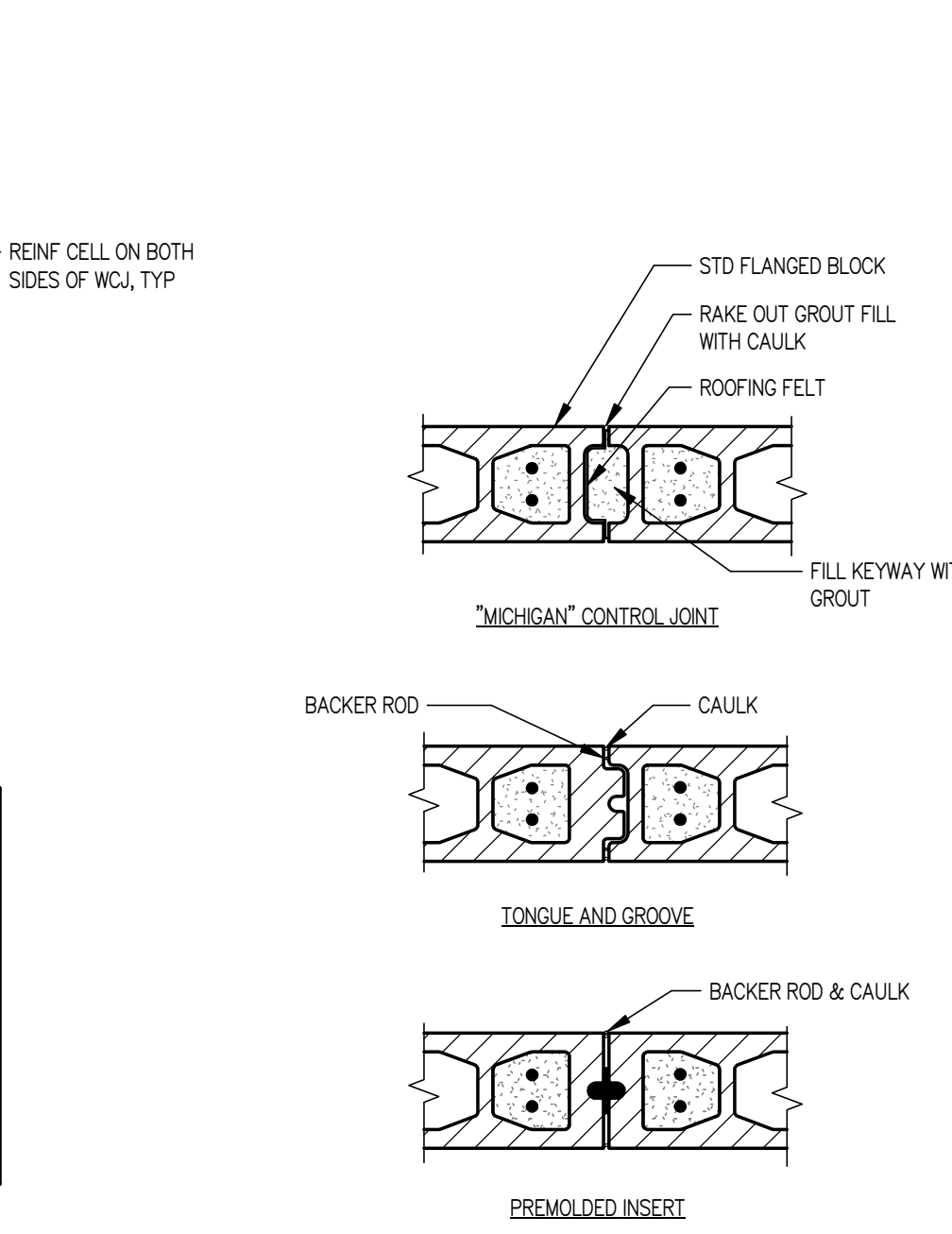

### 3 MASONRY CONTROL JOINTS

S701 SCALE: 1" = 1'-0"

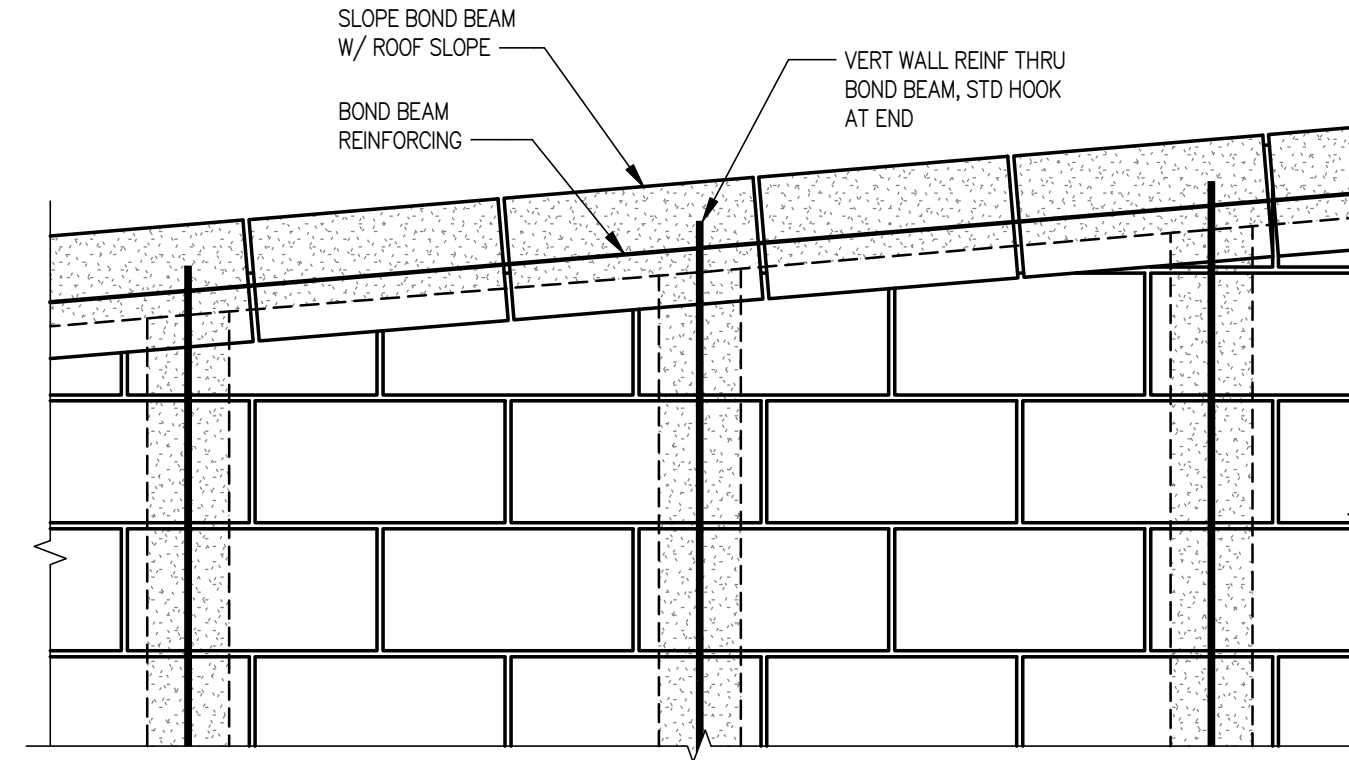

### 7 TYPICAL OFFSET BOND BEAM

S701 SCALE: 1" = 1'-0"

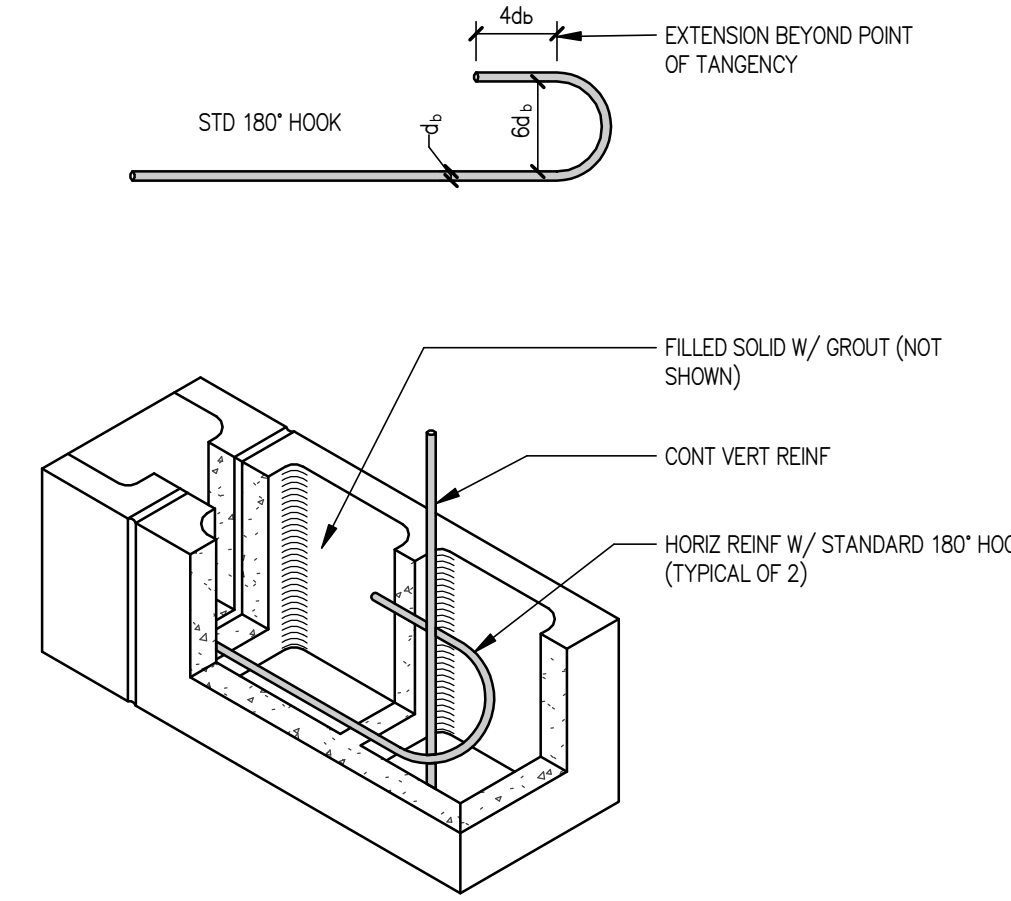

### 4 BOND BEAM REINFORCING TERMINATION

S701 SCALE: NTS

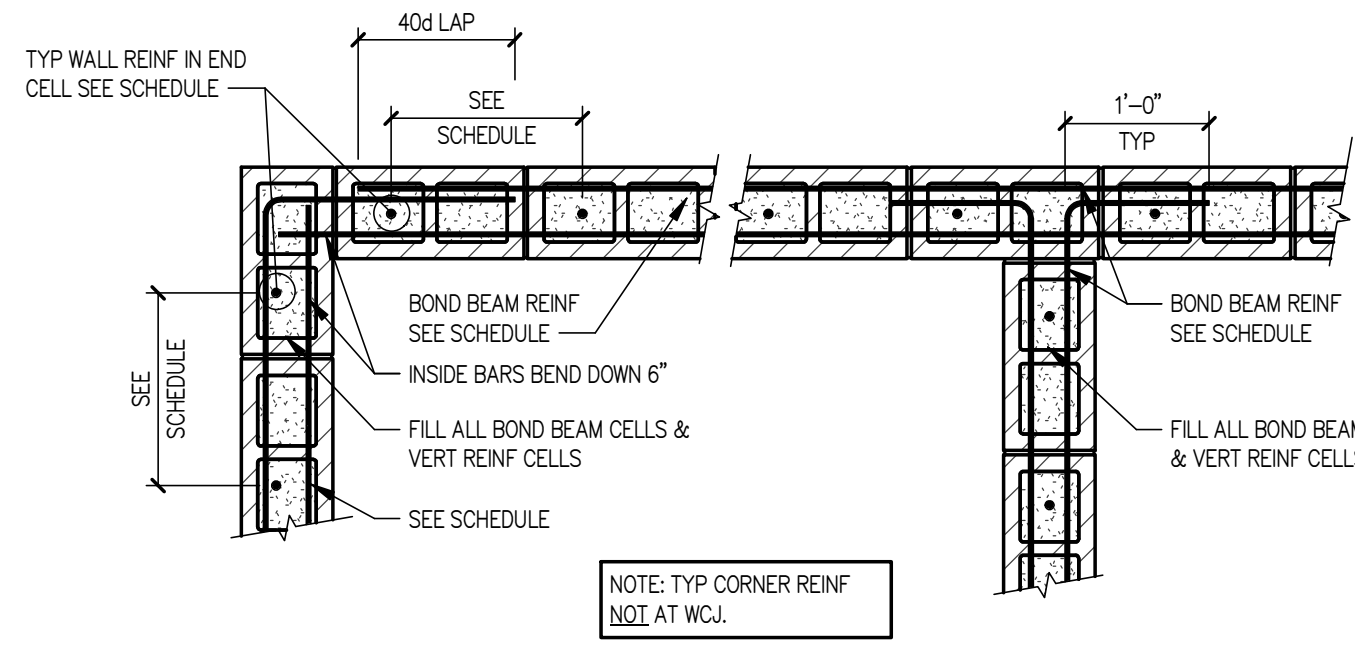

### 5 MASONRY CORNER REINFORCING

S701 SCALE: 3/4" = 1'-0"

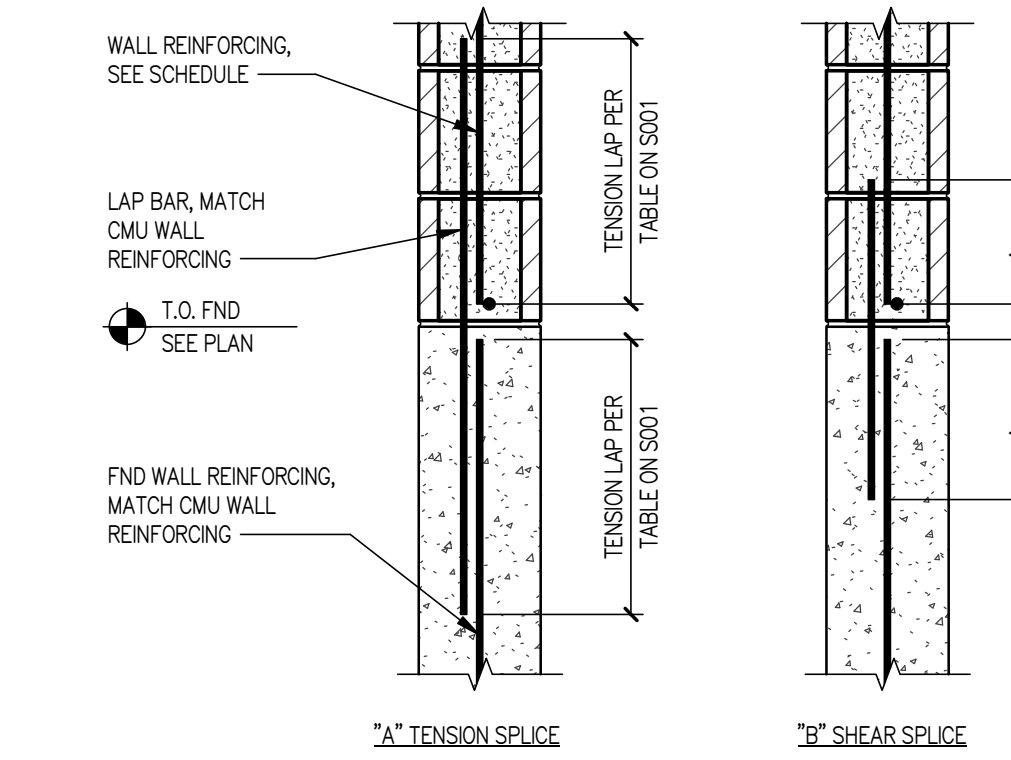

### 8 CMU WALL TO END WALL

S701 SCALE: 1" = 1'-0"

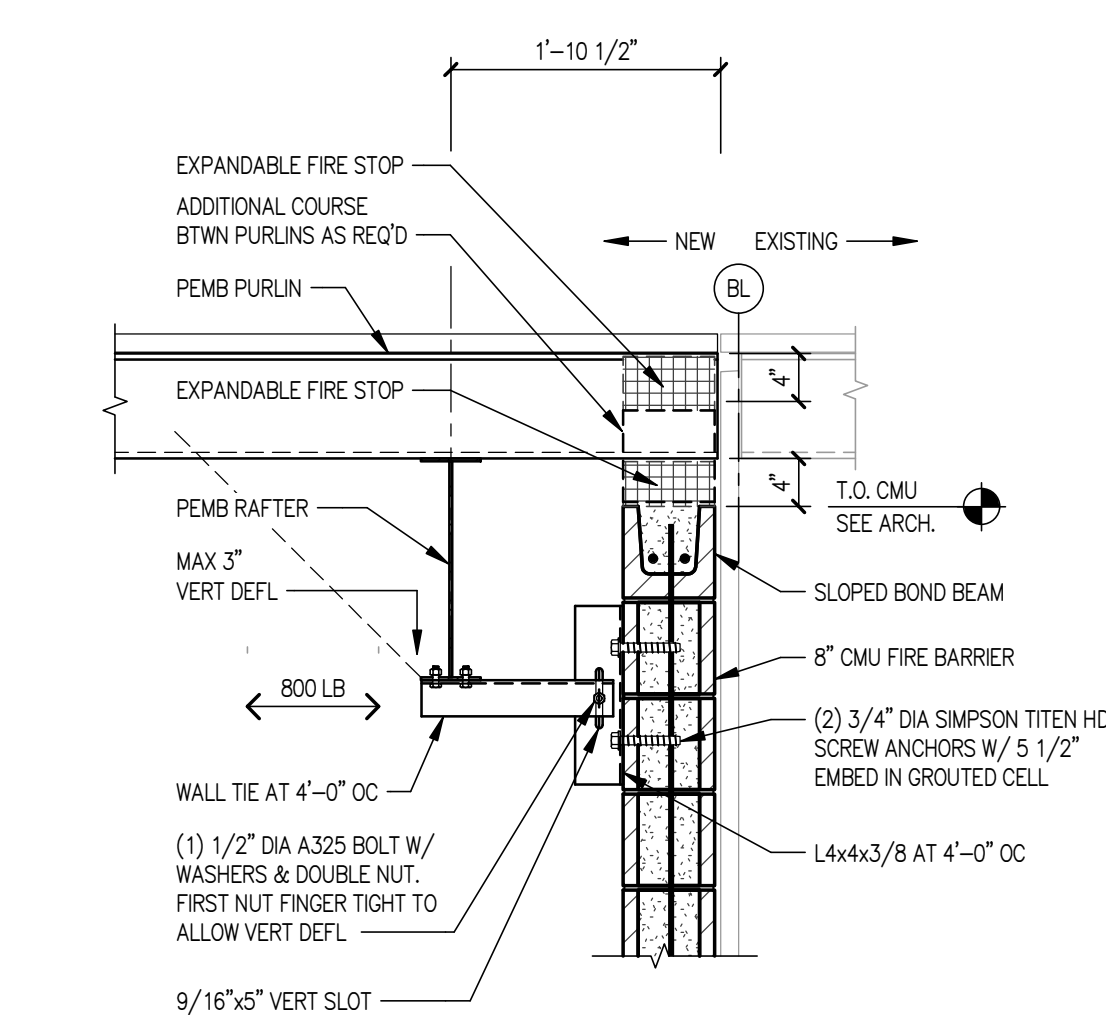

### 9 DETAIL AT TOP OF CMU FIRE BARRIER

S701 SCALE: 3/4" = 1'-0"

MARK	SIZE	REMARKS
L1	8" CMU W/ (2)#4	MAX 4'-0" OPENING
L2	16" CMU W/ (2)#5 TOP & BOT	

1. CENTER LINTEL IN WALL UNLESS NOTED OTHERWISE.
2. HOLD BOTTOM PL BACK 1" CLEAR FROM BEARING.

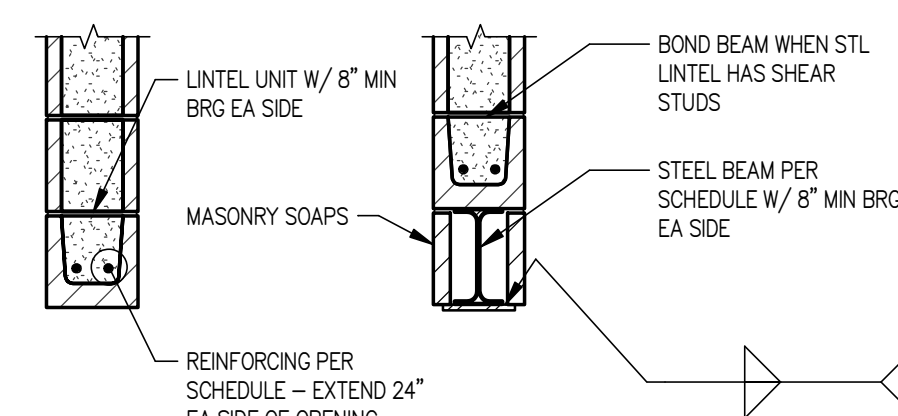

### 10 CMU LINTEL SCHEDULE

S701 SCALE: 3/4" = 1'-0"

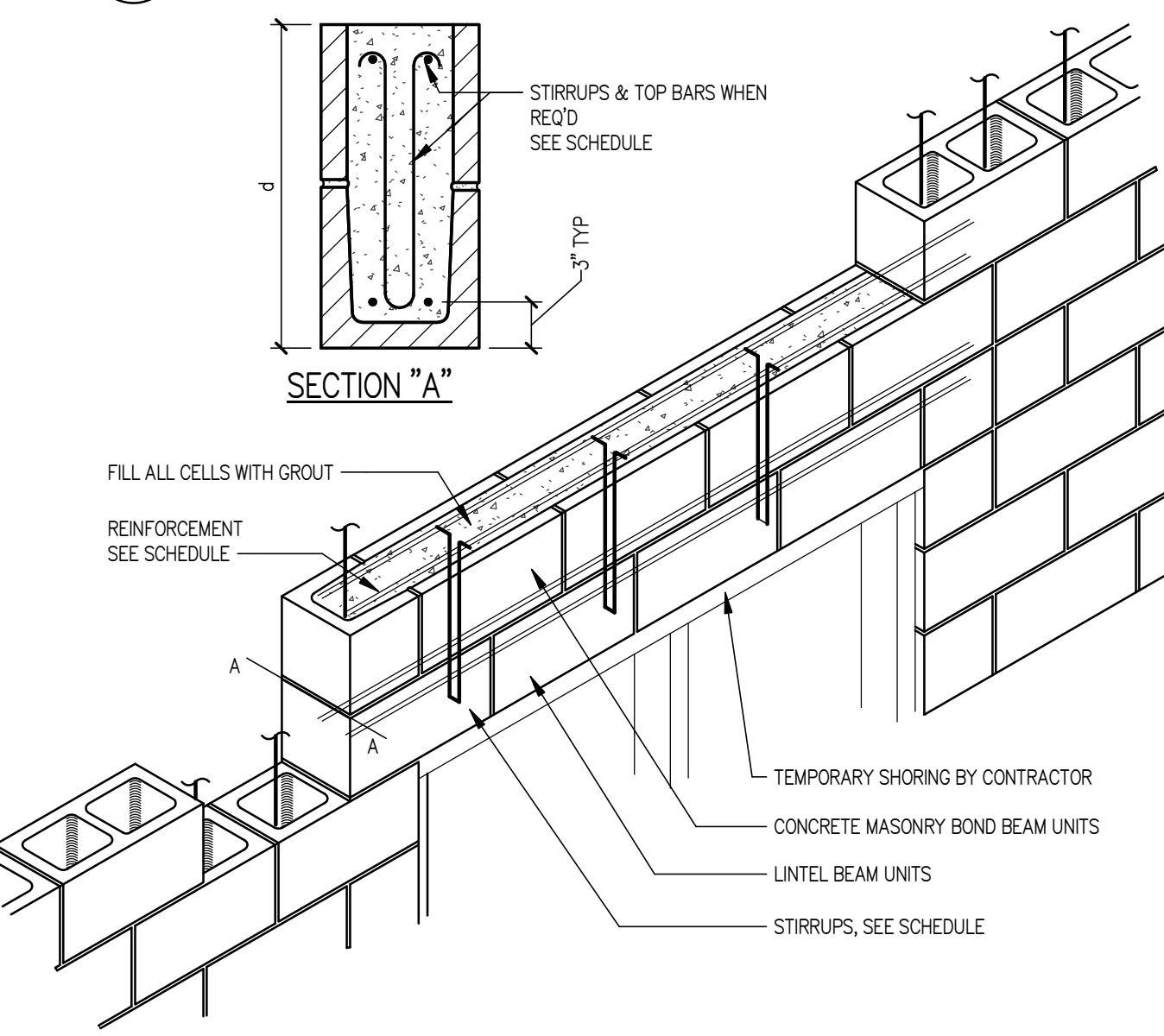

### 11 TYPICAL CMU LINTEL

S701 SCALE: 3/4" = 1'-0"

**BUILDING ADDITION**  
CITY OF EVANSVILLE  
535 S MADISON ST  
EVANSVILLE, WI

#### Project Status

1	03.19.2021	FOR CONSTRUCTION
---	------------	------------------

PROJ. #: 20001-01

© SKETCHWORKS ARCHITECTURE 2020

**MASONRY DETAILS**

**S701**

**FOR CONSTRUCTION**

1

2

3

4

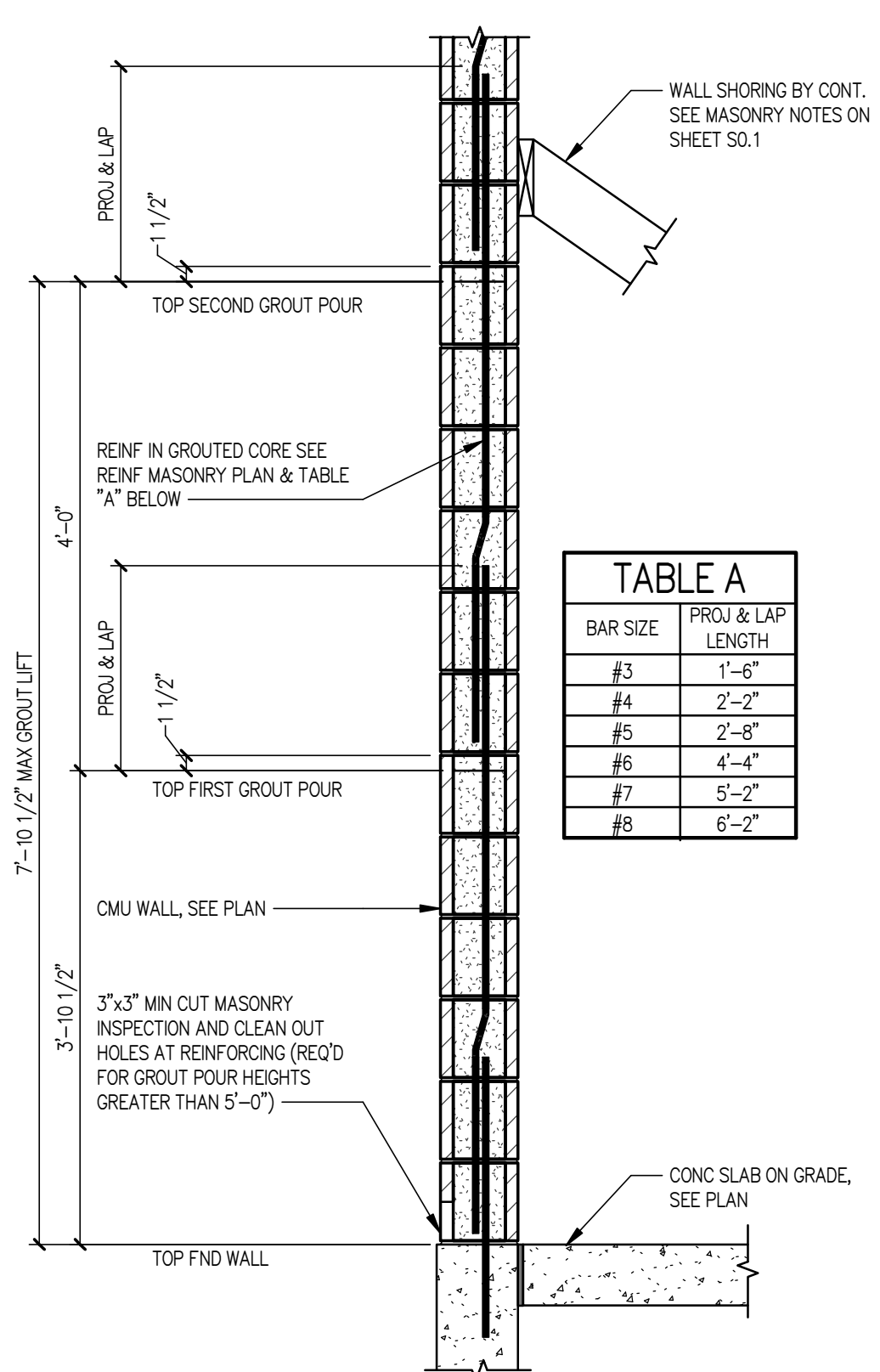

1  
S702 TYP REINFORCED CMU WALL  
SCALE: 3/4" = 1'-0"

BAR SIZE	PROJ. & LAP LENGTH
#3	1'-5"
#4	2'-2"
#5	2'-8"
#6	4'-4"
#7	5'-2"
#8	6'-2"

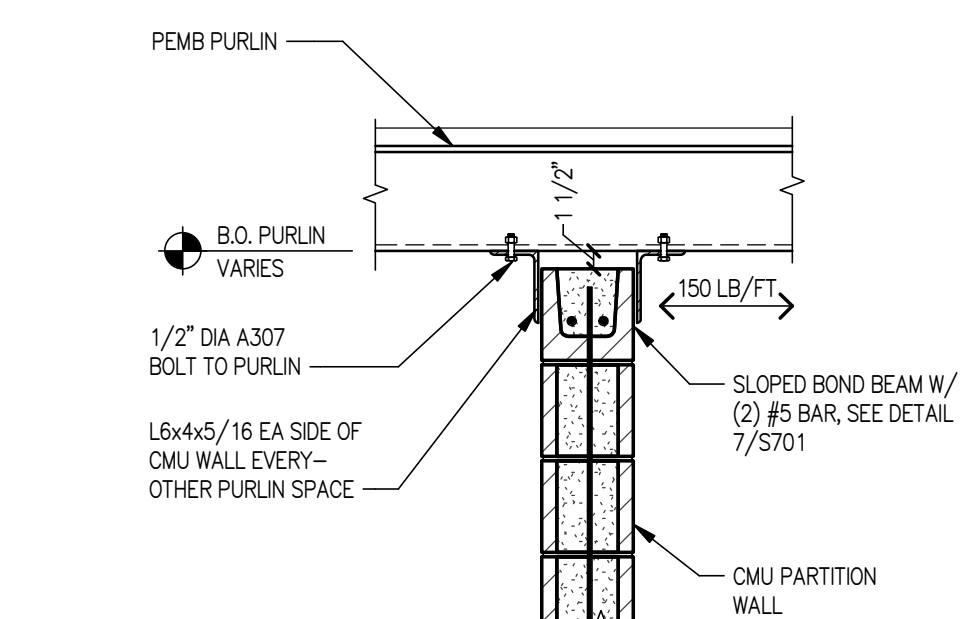

2  
S702 DETAIL AT TOP OF CMU PARTITION WALL (PERPENDICULAR)  
SCALE: 3/4" = 1'-0"

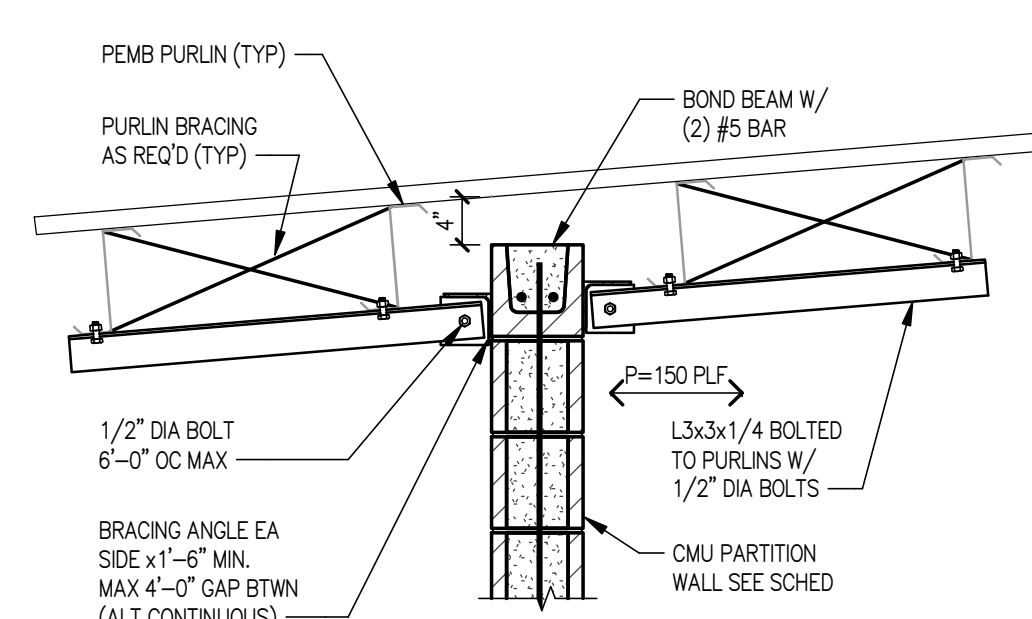

3  
S702 DETAIL AT TOP OF CMU PARTITION WALL (PARALLEL)  
SCALE: 3/4" = 1'-0"

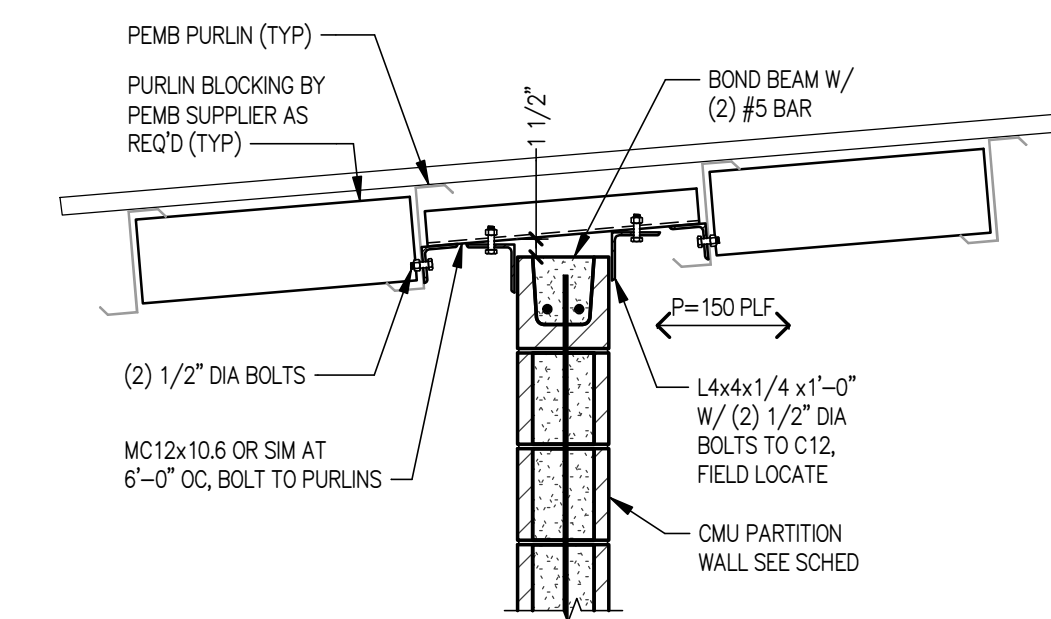

4  
S702 DETAIL AT TOP OF CMU PARTITION WALL (PARALLEL) ALT  
SCALE: 3/4" = 1'-0"

**Project Status**

	DATE	FOR
1	03.19.2021	FOR CONSTRUCTION

PROJ. #: 20001-01

© SKETCHWORKS  
ARCHITECTURE 2020

**MASONRY  
DETAILS**

**S702**

**FOR CONSTRUCTION**

COMMON ABBREVIATIONS:

NOTE: ANY ABBREVIATIONS APPEARING IN THESE DOCUMENTS WHICH ARE NOT LISTED BELOW SHALL BE VERIFIED AND CONFIRMED WITH THE ARCHITECT PRIOR TO CONSTRUCTION

Table of abbreviations including AB (Anchor Bolt), ACT (Acoustical Ceiling Tile), ADA (Americans with Disabilities Act), etc., organized in columns.

ARCHITECTURAL SYMBOLS:

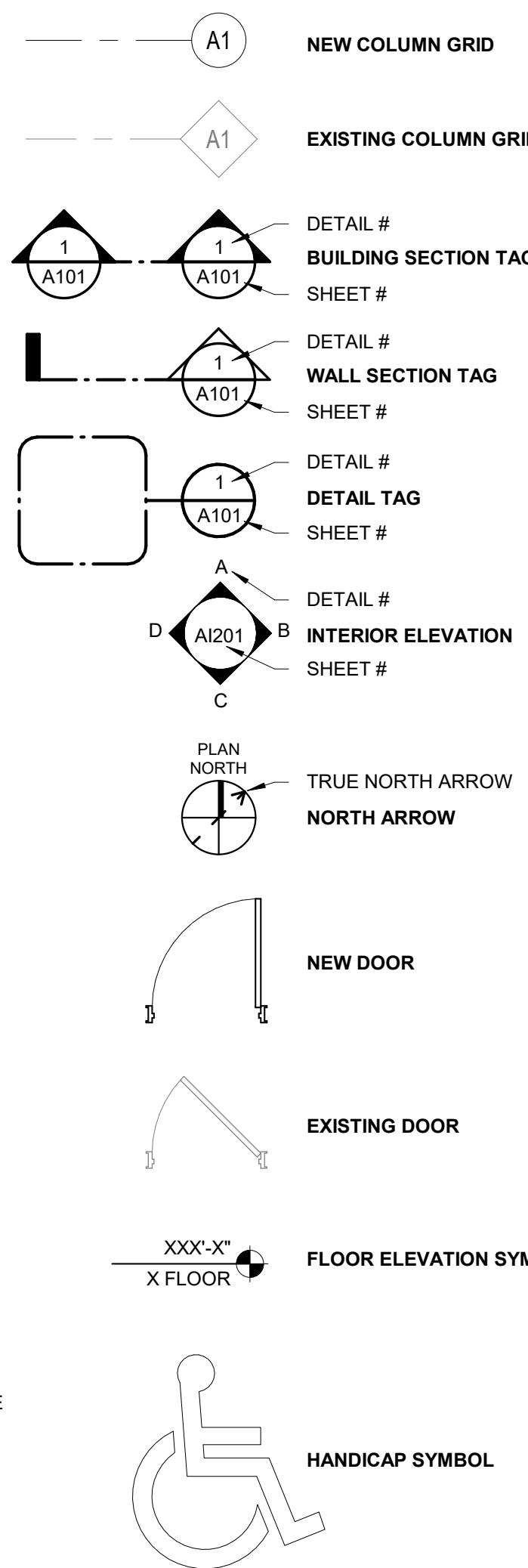

ARCHITECTURAL TAGS & KEYNOTES:

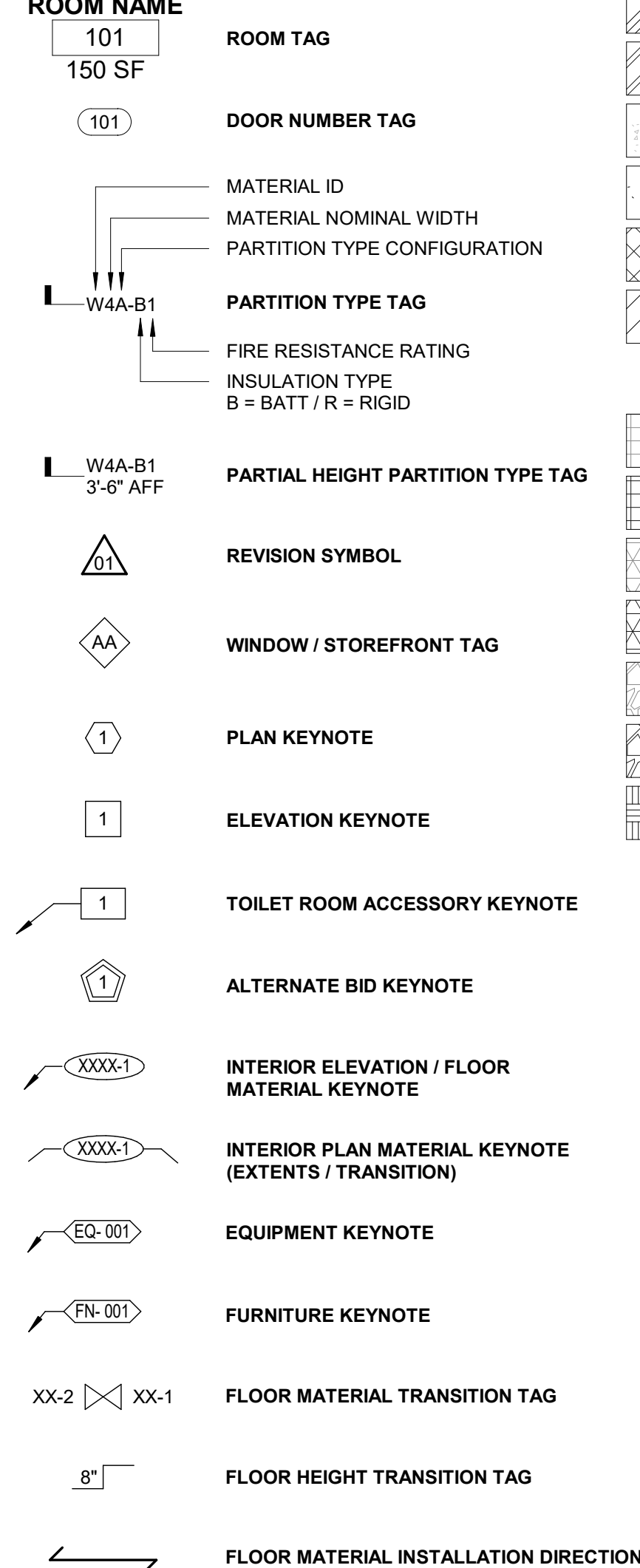

ARCHITECTURAL HATCH PATTERNS:

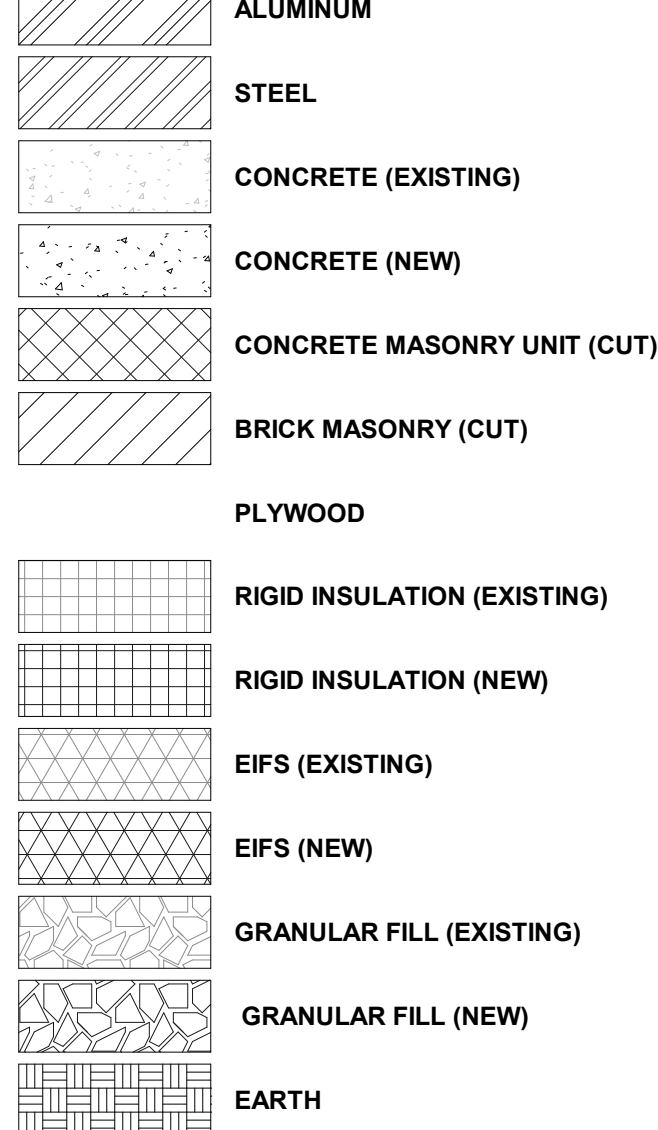

CLEARANCES AT MANUAL DOOR SWINGS:

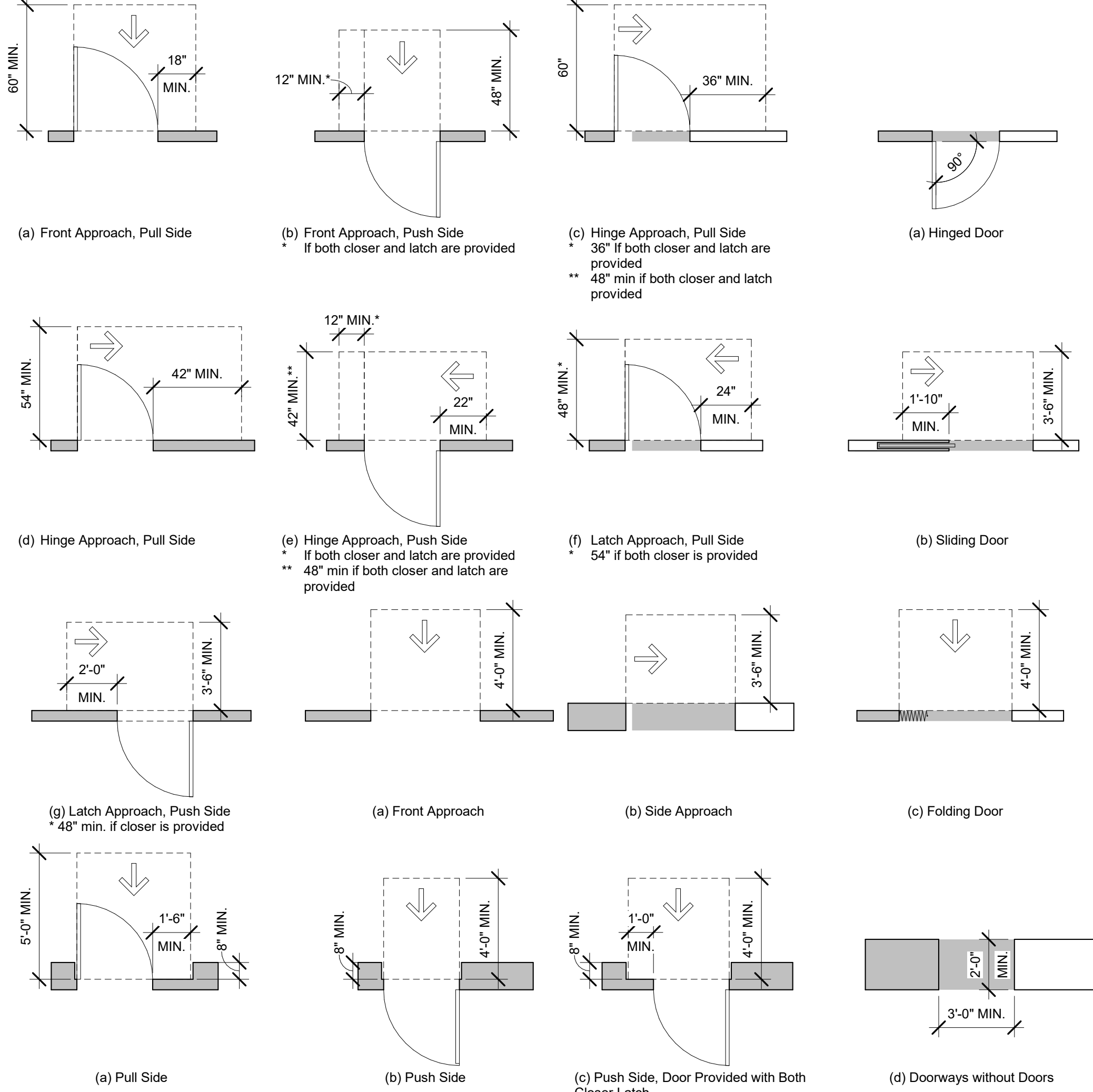

NOTE: THE INFORMATION ON THIS SHEET IS FOR ILLUSTRATIVE PURPOSES AND TO PROVIDE EASE OF ACCESS TO INFORMATION FOR THE GC AND SUB-CONTRACTORS. IT IS THE RESPONSIBILITY OF THE GC AND SUB-CONTRACTORS TO BE KNOWLEDGEABLE OF THE FAIR HOUSING ACT GUIDELINES (FFHAG), THE AMERICANS WITH DISABILITIES ACT GUIDELINES (ADAAG), AND THE AMERICAN NATIONAL STANDARDS INSTITUTE GUIDELINES (ANSI A117.1) TO EXECUTE THEIR WORK IN COMPLIANCE WITH THESE GUIDELINES.

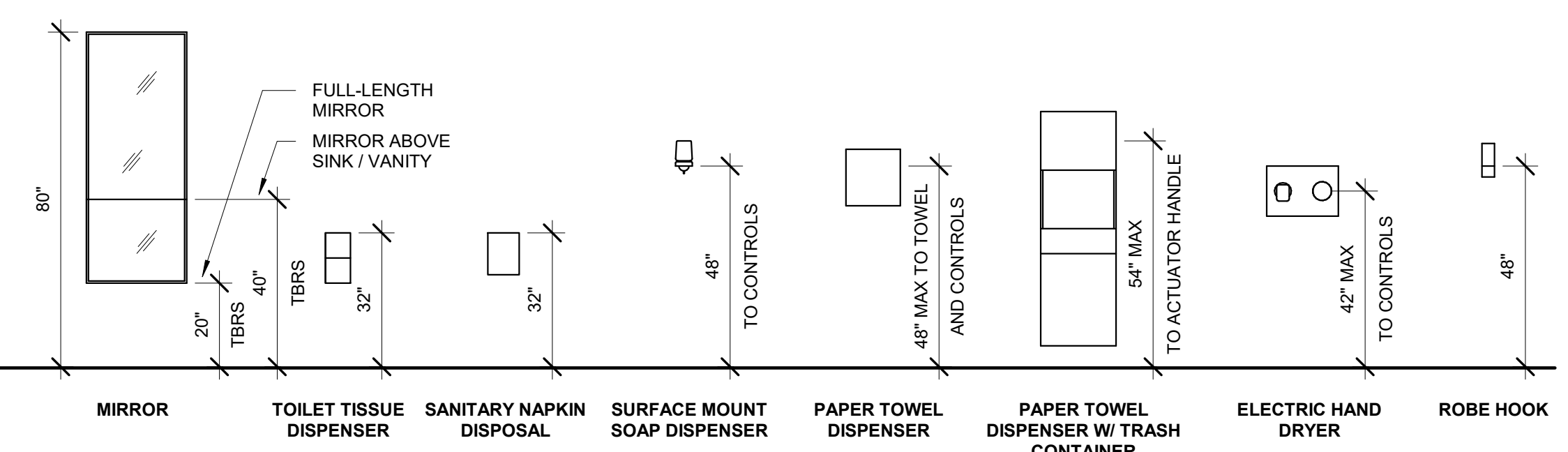

COMMERCIAL TOILET ROOM ACCESSORY MOUNTING HEIGHTS 3/8" = 1'-0"

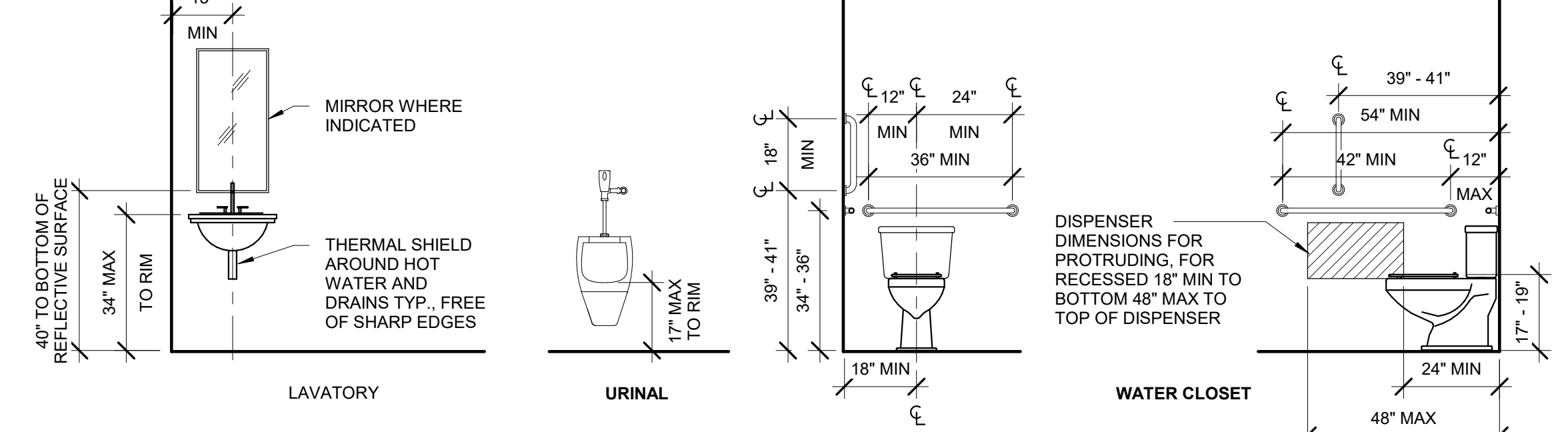

COMMERCIAL TOILET ROOM FIXTURES 3/8" = 1'-0"

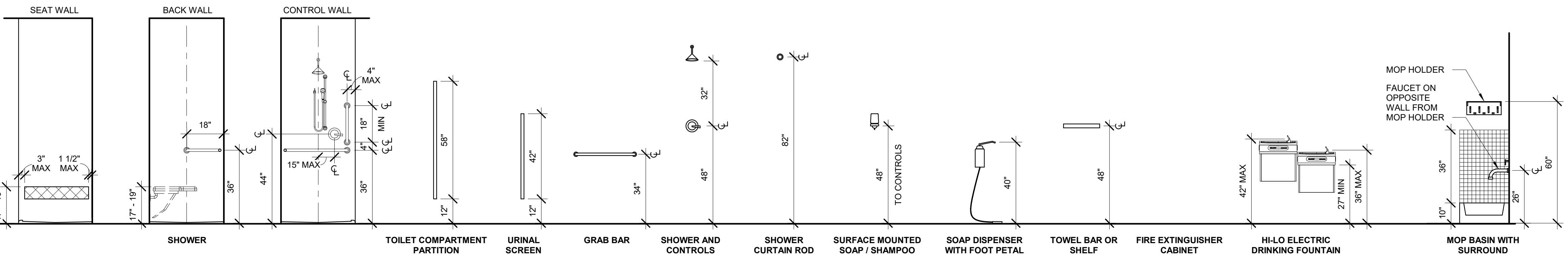

COMMERCIAL PLUMBING FIXTURE AND ACCESSORY MOUNTING HEIGHTS 3/8" = 1'-0"

Project Status

Table with Project Status: 2021.03.19 FOR CONSTRUCTION

PROJ. #: 20119-01

© SKETCHWORKS ARCHITECTURE 2021

SYMBOLS & ABBREVIATIONS

**PARTITION TYPE NOTES:**

- A. SEE 2009 UNDERWRITER'S LABORATORY DIRECTORY FOR ADDITIONAL INFORMATION ON WALL RATING SPECIFICS AND ALLOWABLE MATERIALS.
- B. PROVIDE TREATED WOOD AT ALL LOCATIONS WHERE WOOD IS IN CONTACT WITH CONCRETE AND/OR MASONRY.
- C. PROVIDE MOISTURE RESISTANT GYPSUM BOARD AT ALL WET AREAS INCLUDING KITCHENS, BATHROOMS, AND RESTROOMS.
- D. PROVIDE ACOUSTICAL INSULATION AND ACOUSTICAL SEALANT AT TOP & BOTTOM OF WALLS AND ALL WALL PENETRATIONS AT ALL CORRIDOR AND UNIT DEMISING WALLS. FOR SOUND IMPROVEMENT, DO NOT ALIGN PENETRATIONS BETWEEN UNITS (EG WALL OUTLETS).
- E. ALL GYPSUM SHALL EXTEND TO BOTTOM OF ROOF DECK OR FULL HEIGHT OF PARTITION UNLSS NOTED OTHERWISE.

D

C

B

A

**"S" WALL TYPE - STEEL FRAMED**

**S4A**

FRP PANELS OVER GYPSUM WALL BOARD, MOISTURE RESISTANT GYPSUM AT ALL WET WALLS

BATT INSULATION

3 5/8" METAL STUD

CONFIGURATIONS	S4A	S4A-B	S4A-B1
GWB TYPE	STANDARD	STANDARD	TYPE X
INSULATION TYPE	N/A	BATT	BATT
FIRE RATING	N/A	N/A	1 HOUR
FIRE TEST	N/A	N/A	UL# U432

**"M" WALL TYPE - MASONRY**

**M8A**

NOTE: 3 HOUR RATED WALLS SHALL HAVE D-3 CLASSIFICATION

PAINTED CMU WALL: SEE STRUCTURAL FOR REINFORCEMENT

CONFIGURATIONS	M8A			
GWB TYPE	N/A			
INSULATION TYPE	N/A			
FIRE RATING	3 HOUR			
FIRE TEST	UL# U905			

**M8B**

PAINTED CMU WALL: SEE STRUCTURAL FOR REINFORCEMENT

3 5/8" METAL STUD

GYPSUM WALL BOARD

CONFIGURATIONS	M8B			
GWB TYPE	STANDARD			
INSULATION TYPE	N/A			
FIRE RATING	N/A			
FIRE TEST	N/A			

**M8C**

PAINTED CMU WALL: SEE STRUCTURAL FOR REINFORCEMENT

CONFIGURATIONS	M8C			
GWB TYPE	N/A			
INSULATION TYPE	N/A			
FIRE RATING	N/A			
FIRE TEST	N/A			

**CITY OF EVANSVILLE**  
 BUILDING ADDITION  
 15 OLD HWY 92  
 EVANSVILLE, WI

**Project Status**

2021.03.19	FOR CONSTRUCTION

PROJ. #: 20119-01

© SKETCHWORKS ARCHITECTURE 2021

**INTERIOR PARTITION TYPES**

**A002**

**FOR CONSTRUCTION**

**GENERAL DEMOLITION  
PLAN NOTES:**

- A. REMOVE ALL "DASHED" WALLS (DEMOLISHED) FROM FLOOR TO DECK WHERE EXISTING MECHANICAL, PLUMBING, ELECTRICAL OR DATA CONNECTIONS ARE ABANDONED DUE TO DEMOLITION WORK OR REMOVAL OF FIXTURES AND ACCESSORIES. CAP EXISTING CONNECTIONS AS REQUIRED PER CODE OR PROVIDE CONNECTOR FOR NEW FIXTURE AND ACCESSORIES WHERE APPLICABLE.
- B. EXISTING EXTERIOR WALLS, STRUCTURE AND FLOORS SHALL REMAIN INTACT AND UNDISTURBED, WHERE MODIFICATION IS NECESSARY, RESTORE TO EXISTING CONDITION. INCLUDING EXISTING AIR/ VAPOR BARRIERS AND THERMAL ENVELOPE DESIGN.
- C. AREAS OF CONCEALED EXISTING BUILDING STRUCTURE TO BE EXPOSED AND EXAMINED DURING DEMOLITION TO VERIFY PROPOSED STRUCTURAL MODIFICATIONS ARE SUFFICIENT. COORDINATE CONSTRUCTION SCHEDULE WITH ARCHITECT AND ENGINEER TO ALLOW ACCESS FOR VERIFICATION. CONTRACTOR SHALL NOTIFY ARCHITECT, ENGINEER, AND OWNER IMMEDIATELY UPON DISCOVERING ANY UNANTICIPATED STRUCTURAL CONDITIONS OR DISCREPANCIES WITH PROPOSED MODIFICATIONS.
- D. PATCH AND REPAIR ADJACENT WALLS AND FLOOR SURFACES TO PROVIDE A UNIFORM FINISH WHERE NECESSARY AT AREAS OF DEMOLITION. LOCATIONS OF REMOVED ACCESSORIES OR HARDWARE, AND ANY NEW OR RELOCATED WALLS. MATCH EXISTING FLOOR FINISHES, WALL FINISHES AND BASE MATERIALS UNLESS OTHERWISE SPECIFIED IN FINISH NOTES, FINISH PLANS, PARTITION TYPES, OR ELSEWHERE ON PLANS.
- E. ALL DIMENSIONS FROM EXISTING WALLS ARE FROM FINISH FACE UNLESS NOTED OTHERWISE.
- F. PREPARE ALL EXISTING AREAS INVOLVED WITH DEMOLITION TO RECEIVE NEW WORK OR NEW FINISHES PER PLANS, ROOM FINISH SCHEDULE AND SPECIFICATIONS. CONTACT ARCHITECT OR ENGINEER BEFORE BEGINNING NEW WORK IF THERE ARE ANY DISCREPANCIES OR QUESTIONS REGARDING EXISTING CONDITIONS NOT CLEARLY DEFINED ON THE DRAWINGS THAT AFFECT NEW CONSTRUCTION.
- G. GENERAL CONTRACTOR TO SECURE CONSTRUCTION AREA DURING CONSTRUCTION WORK, SEAL ALL DOORS AS REQUIRED. CONSTRUCT AND MAINTAIN A FLOOR TO CEILING DUST BARRIER, TO PROVIDE SEPARATION FOR DUST, DEBRIS AND SOUND.
- H. GENERAL CONTRACTOR TO COORDINATE CONSTRUCTION SCHEDULE TO MINIMIZE IMPACT ON EXISTING BUILDING OPERATIONS AND PLANNED EVENTS. CONSTRUCTION SPACE MUST BE CLEAN AND AVAILABLE FOR USE PERIODICALLY PER OWNERS REQUEST. VERIFY SCHEDULED EVENTS WITH OWNER PRIOR TO CONSTRUCTION START AND ARRANGE CONSTRUCTION SCHEDULE TO MEET OWNER'S NEEDS. COORDINATE SYSTEMS AND UTILITY SHUT DOWNS WITH OWNER PRIOR TO COMMENCEMENT OF WORK.
- I. GENERAL CONTRACTOR TO MAINTAIN A CLEAR PATH THROUGH PORTIONS OF THE CONSTRUCTION AREA FOR ACCESS TO EGRESS ROUTES.

**HATCH PATTERN KEY:**

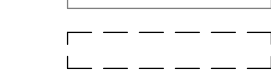
-  EXISTING CONSTRUCTION
-  DEMO CONSTRUCTION

**# DEMO PLAN KEYNOTES:**

- 1 REMOVE EXISTING CONCRETE STOOP
- 2 REMOVE EXISTING MAN DOOR AND FRAME

**CITY OF EVANSVILLE**  
BUILDING ADDITION  
15 OLD HWY 92  
EVANSVILLE, WI

**Project Status**

2021.03.19	FOR CONSTRUCTION

PROJ. #: 20119-01

© SKETCHWORKS  
ARCHITECTURE 2021

**DEMOLITION  
FLOOR PLAN**

**AD101**

D  
C  
B  
A

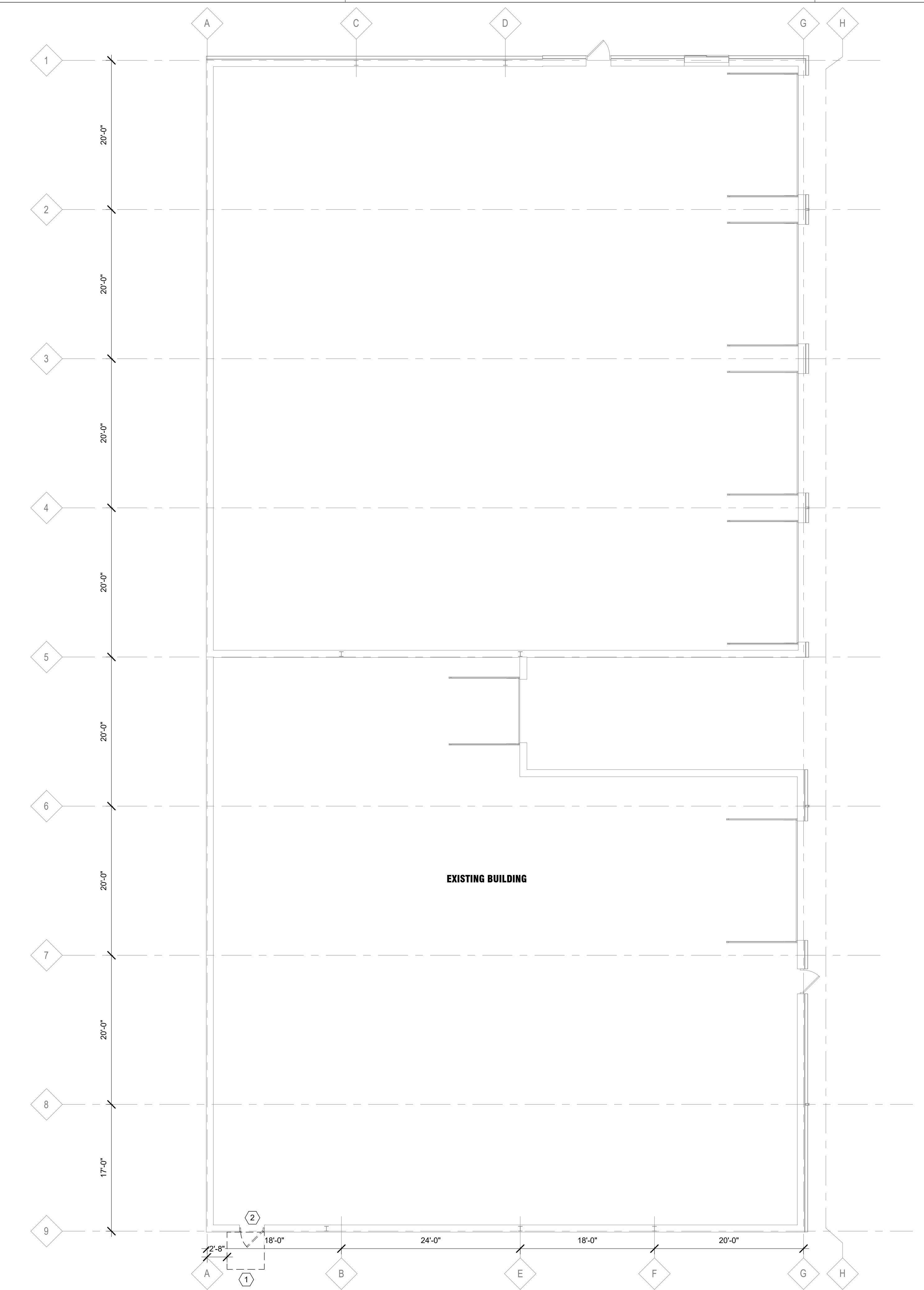

**A1 FLOOR PLAN DEMOLITION**  
1/8" = 1'-0"

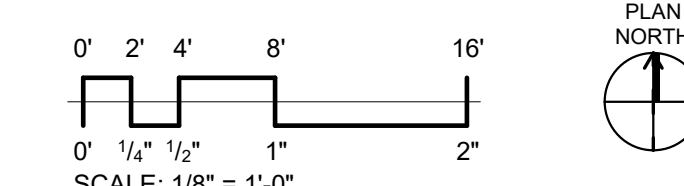



**FOR CONSTRUCTION**



**GENERAL PLAN NOTES:**

- A. MECHANICAL, ELECTRICAL, PLUMBING IMPROVEMENTS TO BE DESIGN BUILD, UNLESS NOTED OTHERWISE. DESIGNED AS REQUIRED BY CURRENT BUILDING CODES. MEP DESIGN BUILD CONTRACTOR(S) RESPONSIBLE FOR ENSURING CODE COMPLIANT CONSTRUCTION OF NEW SYSTEMS.
- B. PROVIDE MOISTURE RESISTANT GWB AT ALL PLUMBING WALLS.
- C. PROVIDE ACCESSIBLE TOILET ROOM FIXTURES AND ACCESSORIES PER MOUNTING HEIGHTS INDICATED ON SHEET A001.
- D. PROVIDE 2x BLOCKING AT ALL GRAB BAR LOCATIONS PER ANSI A117.1 2009
- E. PROVIDE ADA APPROVED THRESHOLDS AT ALL NEW FLOOR TRANSITIONS AND DOORWAYS.
- F. EXTERIOR DIMENSIONS ARE FROM GRIDLINE TO GRIDLINE, OR TO EDGE OF FOUNDATION WALL UNLESS NOTED OTHERWISE. PLEASE CONTACT ARCHITECT WITH ANY DISCREPANCIES.
- G. INTERIOR DIMENSIONS FOR NEW CONSTRUCTION ARE TO FACE OF FRAME OR COLUMN CENTERLINE UNLESS NOTED OTHERWISE. ALL DIMENSIONS FROM EXISTING WALLS ARE FROM FINISH FACE UNLESS NOTED OTHERWISE.
- H. ALL DOORS WITH A CLOSE PROXIMITY OF A PERPENDICULAR WALL SHALL HAVE A TYPICAL DIMENSION OF 6" FROM FACE OF FRAME TO DOOR OPENING UNLESS NOTED OTHERWISE.
- I. VERIFY ALL EXISTING CONDITIONS AND ADJUST WALL DIMENSIONS ACCORDINGLY. CONTACT ARCHITECT WITH ANY DISCREPANCIES.
- J. CONTRACTOR SHALL NOTIFY ARCHITECT, ENGINEER AND OWNER IMMEDIATELY UPON DISCOVERING ANY UNANTICIPATED STRUCTURAL CONDITIONS OR DISCREPANCIES WITH PROPOSED MODIFICATIONS.
- K. FIRE EXTINGUISHER CABINETS SHALL BE RATED TO MEET THE ASSOCIATED WALL FIRE RATING.
- L. GENERAL CONTRACTOR TO SECURE CONSTRUCTION AREA DURING CONSTRUCTION WORK. SEAL ALL DOORS AS REQUIRED. CONSTRUCT AND MAINTAIN A FLOOR TO CEILING DUST BARRIER, TO PROVIDE SEPARATION FOR DUST, DEBRIS AND SOUND.
- M. GENERAL CONTRACTOR TO COORDINATE CONSTRUCTION SCHEDULE TO MINIMIZE IMPACT ON EXISTING BUILDING OPERATIONS AND PLANNED EVENTS. CONSTRUCTION SPACE MUST BE CLEAN AND AVAILABLE FOR USE PERIODICALLY PER OWNERS REQUEST. VERIFY SCHEDULED EVENTS WITH OWNER PRIOR TO CONSTRUCTION START AND ARRANGE CONSTRUCTION SCHEDULE TO MEET OWNER'S NEEDS. COORDINATE SYSTEMS AND UTILITY SHUT DOWNS WITH OWNER PRIOR TO COMMENCEMENT OF WORK.
- N. SUBMIT ALL FINISHES TO THE ARCHITECT FOR APPROVAL.

**HATCH PATTERN KEY:**

-  NEW CONSTRUCTION
-  EXISTING CONSTRUCTION

**CITY OF EVANSVILLE**

**BUILDING ADDITION**

**15 OLD HWY 92  
EVANSVILLE, WI**

**Project Status**

2021.03.19	FOR CONSTRUCTION

PROJ. #: 20119-01

© SKETCHWORKS  
ARCHITECTURE 2021

**OVERALL  
FLOOR PLAN**

**A101**

D  
C  
B  
A

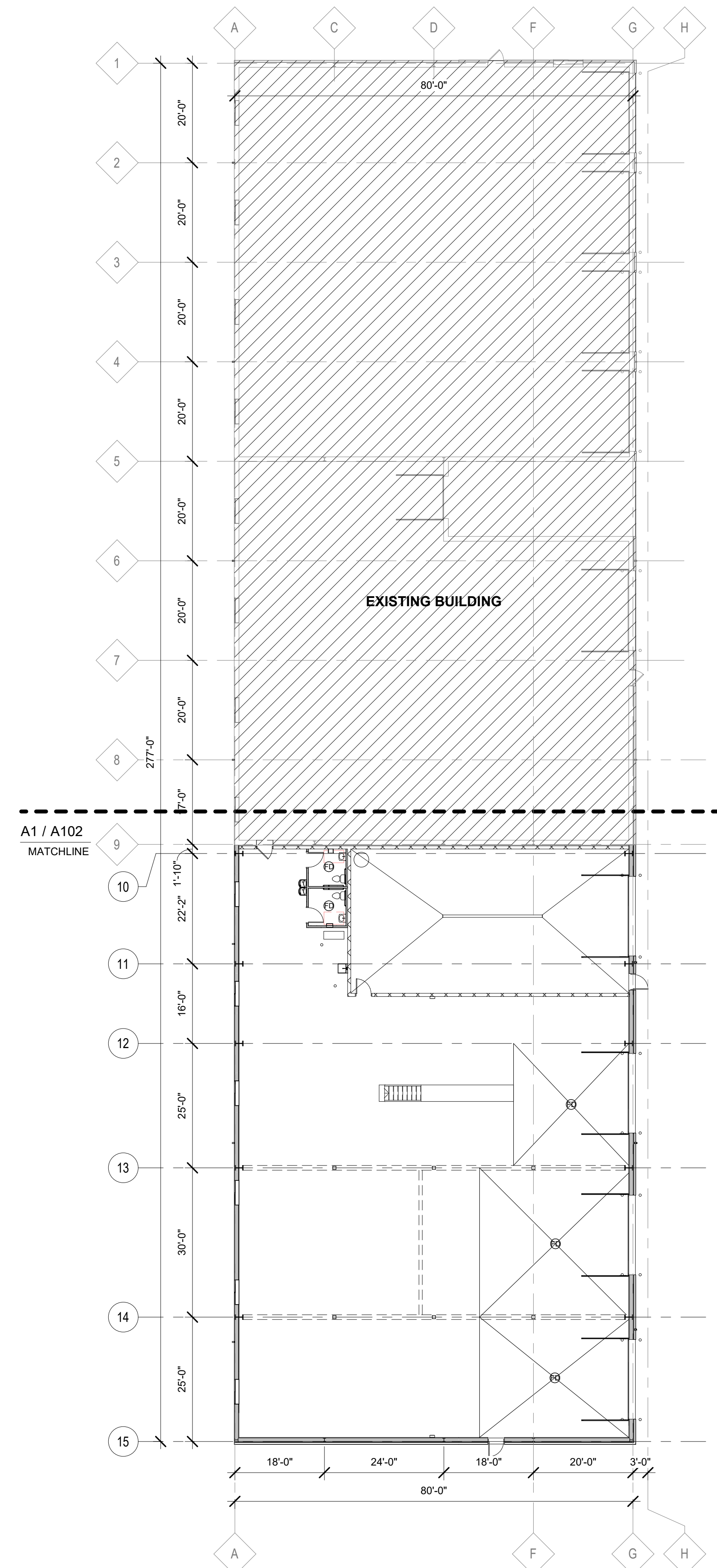

**A3 OVERALL FLOOR PLAN**  
1/16" = 1'-0"



**FOR CONSTRUCTION**

**ALTERNATE BIDS:**

- 1 PROVIDE PRICING DEDUCT TO REMOVE ALL WASH BAY EQUIPMENT FROM PROJECT. REMOVE HOTSY PRESSURE WASHING SYSTEM, ASSOCIATED PIPING AND EQUIPMENT.
- 2 PROVIDE PRICING DEDUCT TO REMOVE BRIDGE CRANE AND ASSOCIATED STRUCTURE/EQUIPMENT FROM PROJECT. REMOVE 3-TON BRIDGE CRANE, ALL RUNAWAYS, COLUMNS AND BRACKETS REQUIRED.
- 3 SCHEDULE FLEXIBILITY- SEE SPECIFICATIONS FOR DETAILS

**GENERAL PLAN NOTES:**

- A. MECHANICAL, ELECTRICAL, PLUMBING IMPROVEMENTS TO BE DESIGN BUILD, UNLESS NOTED OTHERWISE. DESIGNED AS REQUIRED BY CURRENT BUILDING CODES. MEP DESIGN BUILD CONTRACTOR(S) RESPONSIBLE FOR ENSURING CODE COMPLIANT CONSTRUCTION OF NEW SYSTEMS.
- B. PROVIDE MOISTURE RESISTANT GWB AT ALL PLUMBING WALLS.
- C. PROVIDE ACCESSIBLE TOILET ROOM FIXTURES AND ACCESSORIES PER MOUNTING HEIGHTS INDICATED ON SHEET A001.
- D. PROVIDE 2x BLOCKING AT ALL GRAB BAR LOCATIONS PER ANSI A117.1 2009
- E. PROVIDE ADA APPROVED THRESHOLDS AT ALL NEW FLOOR TRANSITIONS AND DOORWAYS.
- F. EXTERIOR DIMENSIONS ARE FROM GRIDLINE TO GRIDLINE, OR TO EDGE OF FOUNDATION WALL UNLESS NOTED OTHERWISE. PLEASE CONTACT ARCHITECT WITH ANY DISCREPANCIES.
- G. INTERIOR DIMENSIONS FOR NEW CONSTRUCTION ARE TO FACE OF FRAME OR COLUMN CENTERLINE UNLESS NOTED OTHERWISE. ALL DIMENSIONS FROM EXISTING WALLS ARE FROM FINISH FACE UNLESS NOTED OTHERWISE.
- H. ALL DOORS WITH A CLOSE PROXIMITY OF A PERPENDICULAR WALL SHALL HAVE A TYPICAL DIMENSION OF 6" FROM FACE OF FRAME TO DOOR OPENING UNLESS NOTED OTHERWISE.
- I. VERIFY ALL EXISTING CONDITIONS AND ADJUST WALL DIMENSIONS ACCORDINGLY. CONTACT ARCHITECT WITH ANY DISCREPANCIES.
- J. CONTRACTOR SHALL NOTIFY ARCHITECT, ENGINEER AND OWNER IMMEDIATELY UPON DISCOVERING ANY UNANTICIPATED STRUCTURAL CONDITIONS OR DISCREPANCIES WITH PROPOSED MODIFICATIONS.
- K. FIRE EXTINGUISHER CABINETS SHALL BE RATED TO MEET THE ASSOCIATED WALL FIRE RATING.
- L. GENERAL CONTRACTOR TO SECURE CONSTRUCTION AREA DURING CONSTRUCTION WORK. SEAL ALL DOORS AS REQUIRED. CONSTRUCT AND MAINTAIN A FLOOR TO CEILING DUST BARRIER, TO PROVIDE SEPARATION FOR DUST, DEBRIS AND SOUND.
- M. GENERAL CONTRACTOR TO COORDINATE CONSTRUCTION SCHEDULE TO MINIMIZE IMPACT ON EXISTING BUILDING OPERATIONS AND PLANNED EVENTS. CONSTRUCTION SPACE MUST BE CLEAN AND AVAILABLE FOR USE PERIODICALLY PER OWNERS REQUEST. VERIFY SCHEDULED EVENTS WITH OWNER PRIOR TO CONSTRUCTION START AND ARRANGE CONSTRUCTION SCHEDULE TO MEET OWNERS NEEDS. COORDINATE SYSTEMS AND UTILITY SHUT DOWNS WITH OWNER PRIOR TO COMMENCEMENT OF WORK.
- N. SUBMIT ALL FINISHES TO THE ARCHITECT FOR APPROVAL.

**HATCH PATTERN KEY:**

- NEW CONSTRUCTION
- EXISTING CONSTRUCTION

**PLAN KEYNOTES:**

- 1 FLOOR TRENCH DRAIN- SLOPE CONCRETE TO DRAIN. 1/4" PER FOOT
- 2 PRESSURE WASHING TROLLEY- PROVIDE REQUIRED ROOM EXHAUST PER MANUF. REQUIREMENT
- 3 PRESSURE WASHING SOAP CONTAINER
- 4 PRESSURE WASHING UNIT- HOTSY HOT WATER HIGH PRESSURE WASHER, 4GPM @ 3000 PSI, 7.5 HP WEG ELECTRIC MOTOR, 208V 3PHASE, 24 AMPFS. BELT DRIVEN HOTSY TRIPLEX PLUNGER PUMP WITH NES TECHNOLOGY, PLC CONTROLLED WITH SMART RELAYS, AUTO START STOP, TIMED SHUT DOWN, OVER RUN PROTECTION AUTO BELT TENSIONER, 24V CONTROLS, 365,000 BTU BURNER W/ ELECTRONIC IGNITION NG FIRED WITH +/-5 DEGREE TEMP FLUCTUATION, ADJUSTABLE TEMP CONTROL UP TO 230 DEGREES, 1/2" SCH. 80 GALVANIZED STEEL COIL, FULLY ENCLOSED INSULATED COIL, POLY FLOAT TANK, HOUR METER, RUPTURE DISC PROTECTION, LOCKABLE PANELS TO LIMIT ACCESS TO MACHINE, WAND, TRIGGER CONTROL, UP STREAM DETERGENT INJECTION, NOZZLE SET, FLOW SWITCH TECHNOLOGY FOR ELECTRONIC IGNITION, UL/ETL APPROVED
- 5 SERVICE SINK
- 6 ADA BI-LEVEL DRINKING FOUNTAINS
- 7 3 TON CAPACITY BRIDGE CRANE ABOVE. PROVIDE COLUMNS AS REQUIRED. SEE STRUCTURAL FOR ADDITIONAL INFORMATION
- 8 OIL CHANGE PIT, SLOPE TO METAL COLLECTION PAN. PROVIDE STEEL STAIRS AND METAL GRATE COVERS, SLIDING OIL CHANGE PAN ON STEEL RAILS. SEE SECTION
- 9 SLOPE FLOOR TO DRAIN- 1/4" PER FOOT
- 10 FIRE EXTINGUISHER CABINET- SURFACE MOUNTED
- 11 6" CONCRETE FILLED PIPE BOLLARD, PAINTED YELLOW
- 12 PAINT ALL EXPOSED STEEL STRUCTURE (COLUMNS, PURLINS) IN WASH BAY 101

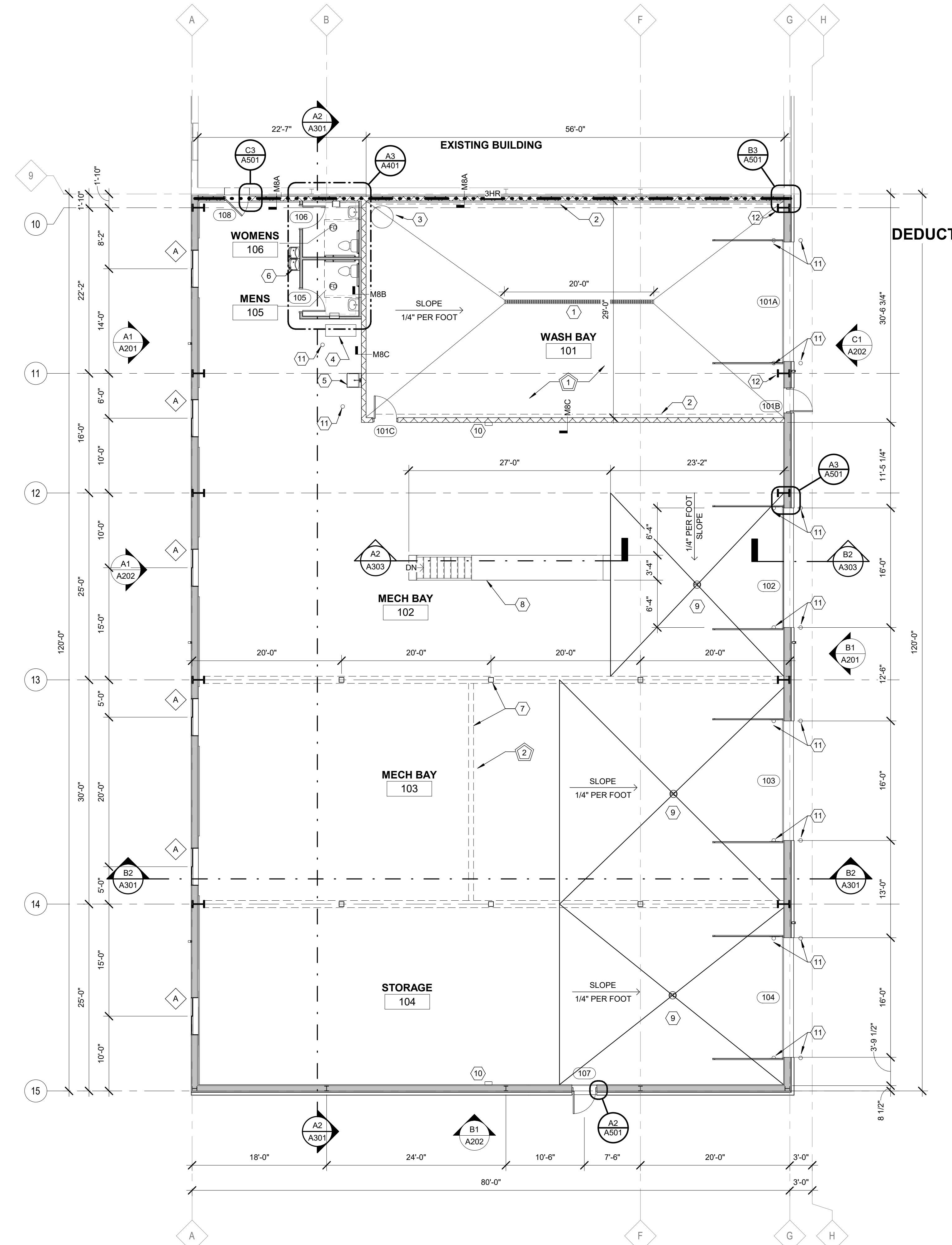

DEDUCT

**A1** FLOOR PLAN ENLARGED  
1/8" = 1'-0"

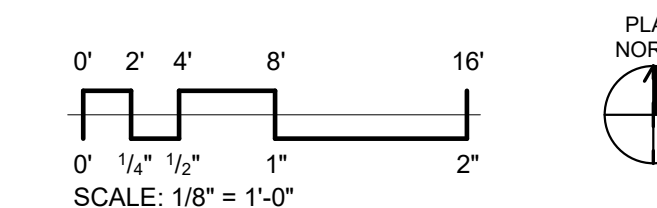

**CITY OF EVANSVILLE**  
BUILDING ADDITION  
15 OLD HWY 92  
EVANSVILLE, WI

**Project Status**

DATE	STATUS
2021.03.19	FOR CONSTRUCTION

PROJ. #: 20119-01

© SKETCHWORKS ARCHITECTURE 2021

**ENLARGED FLOOR PLAN**

**A102**

**FOR CONSTRUCTION**

1

2

3

4

### REFLECTED CEILING PLAN GENERAL NOTES:

- A. COORDINATE HVAC WITH ARCHITECT PRIOR TO INSTALLATION (SUPPLY DIFFUSERS, RETURN LOUVERS, TRANSFER GRILLS, EXHAUST GRILLS, AND ANY OTHER FIXTURE).
- B. LIGHTING SHOWN FOR ILLUSTRATIVE PURPOSES ONLY. LIGHT FIXTURES TO BE DESIGNED BY ELECTRICIAN OR LIGHTING DESIGNER. COORDINATE LIGHTING LAYOUT WITH ARCHITECT PRIOR TO INSTALLATION.
- C. FOLLOW THE STATE AND NATIONAL CODE REQUIREMENTS AND MINIMUM FOOT CANDLE REQUIREMENTS.
- D. MEP & FP CONTRACTORS SHALL COORDINATE WITH ARCHITECT PRIOR TO CONSTRUCTION START TO MINIMIZE CEILING MOUNTED FIXTURES AND EQUIPMENT. CONDUIT SHALL BE RUN AT 90 DEGREE ANGLES TO THE SPACE. UNLESS NOTED OTHERWISE, AND SHALL BE CONCEALED WHERE POSSIBLE.

### CEILING PLAN FIXTURES:

- 2x4' SUSPENDED LIGHT  
• LED BULB  
• TRACE LIT EHB SERIES- HIGH PERFORMANCE LED LINEAR HIGHBAY
- 1x4' SURFACE MOUNTED FIXTURE  
• LED BULB  
• CF/CI
- 6" CAN LIGHT-EXTERIOR RATED  
• LED BULB  
• CF/CI
- 4" CAN LIGHT  
• LED BULB  
• CF/CI
- EXHAUST FAN
- VANITY LIGHT ABOVE MIRROR  
• LED BULB  
• BROWNLEE LIGHTING- FORMA, NT FINISH
- EMERGENCY EXIT LIGHT  
• LED BULB  
• CF/CI
- WALL PACK LIGHT  
• LED BULB  
• RAB OUTDOOR WALL PACK FIXTURE, BLACK FINISH

### # RCP KEYNOTES:

- 1 PAINT ALL EXPOSED STEEL STRUCTURE (COLUMNS, PURLINS) IN WASH BAY 101

D

C

B

A

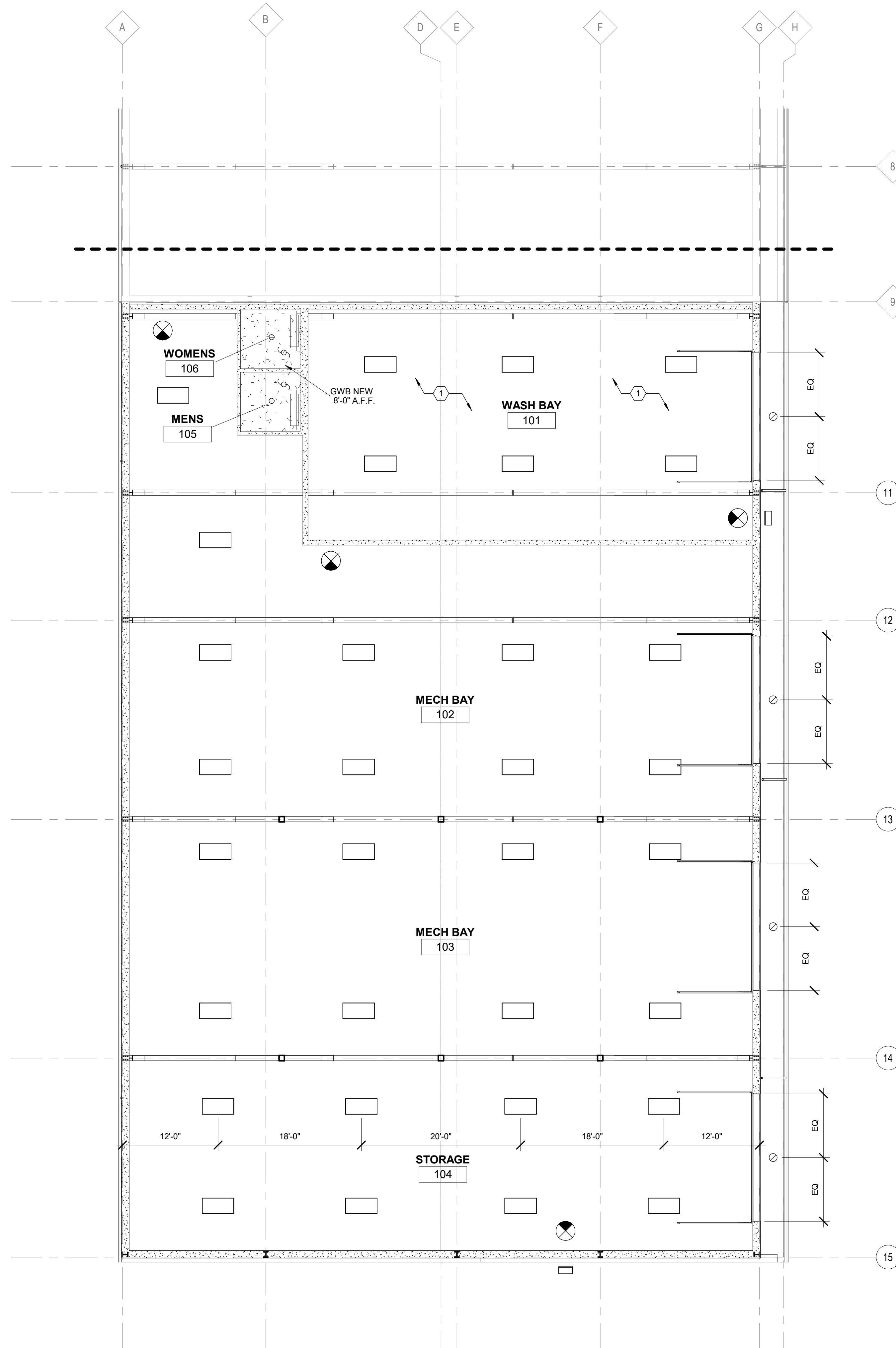

**A2** REFLECTED CEILING PLAN  
1/8" = 1'-0"

## CITY OF EVANSVILLE

**BUILDING ADDITION**  
15 OLD HWY 92  
EVANSVILLE, WI

### Project Status

2021.03.19	FOR CONSTRUCTION

PROJ. #: 20119-01

© SKETCHWORKS  
ARCHITECTURE 2021

## REFLECTED CEILING PLAN

**A103**

**FOR CONSTRUCTION**



ROOF PLAN GENERAL NOTES:

- A. EXTERIOR DIMENSIONS ARE FROM GRIDLINE TO GRIDLINE, OR TO EDGE OF FOUNDATION WALL UNLESS OTHERWISE NOTED. PLEASE CONTACT ARCHITECT WITH ANY DISCREPANCIES.
- B. DIMENSIONS ARE TO FACE OF [EAVE] UNLESS NOTED OTHERWISE. VERIFY ALL EXISTING CONDITIONS AND ADJUST WALL DIMENSIONS ACCORDINGLY. CONTACT ARCHITECT WITH ANY DISCREPANCIES.
- C. FINAL DOWNSPOUT LOCATION(S) SHOULD BE COORDINATED BETWEEN THE ROOFING CONTRACTOR, THE ARCHITECT AND THE CIVIL ENGINEER. VERIFY LOCATION OF DOWNSPOUTS.

# ROOF PLAN KEYNOTES:

- 1 DOWNSPOUT LOCATION
- 2 PEMB MANUFACTURER TO SIZE ROOF STRUCTURE FOR FUTURE PHOTOVOLTAIC PANELS. PANELS TO LAY FLAT ON ROOF. PEMB TO ACCOUNT FOR 4 PSF FOR FUTURE PV PANELS
- 3 SINGLE RAIL SNOW GUARD- S-SI SNORAIL OR SIM.

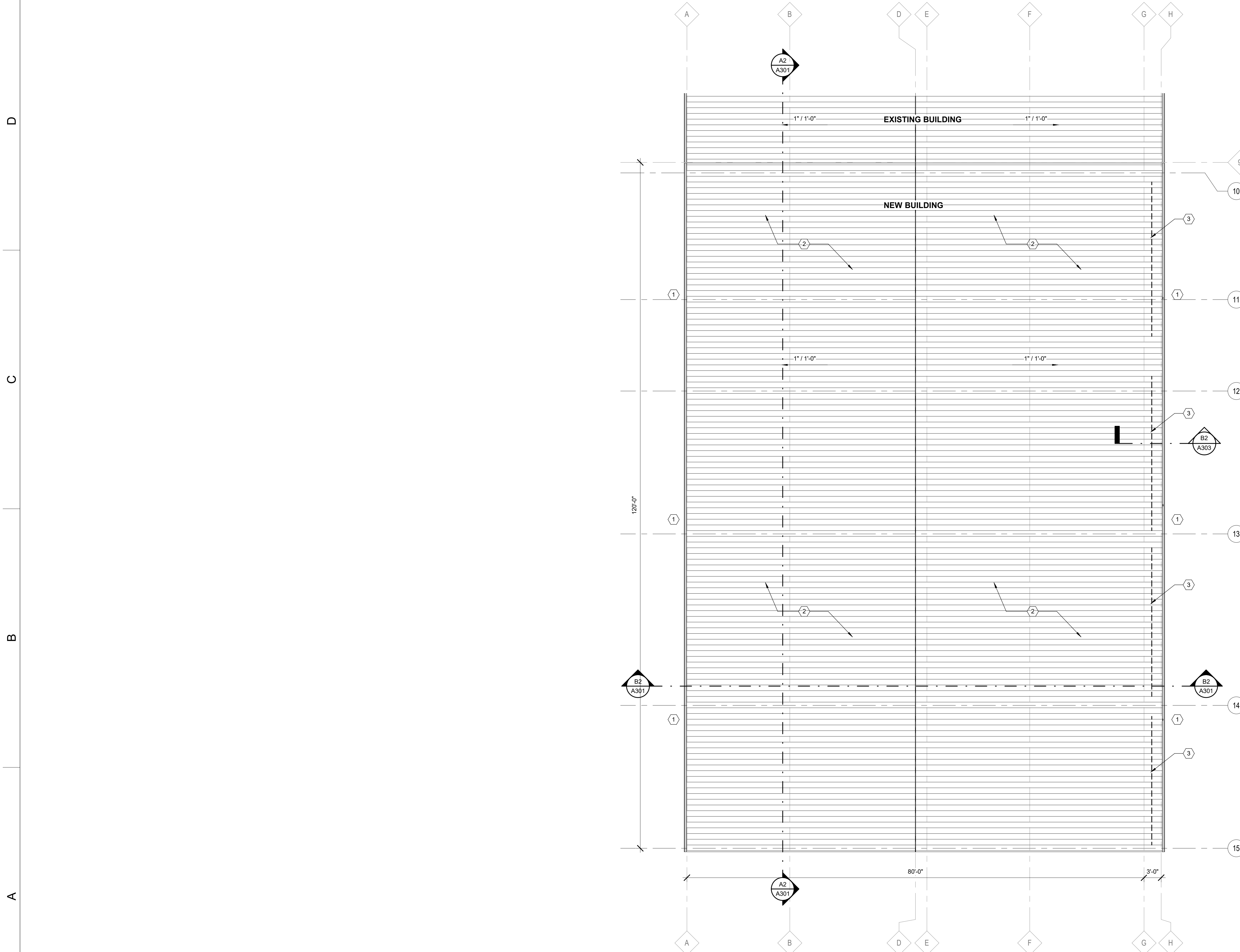

A2 ROOF PLAN  
1/8" = 1'-0"

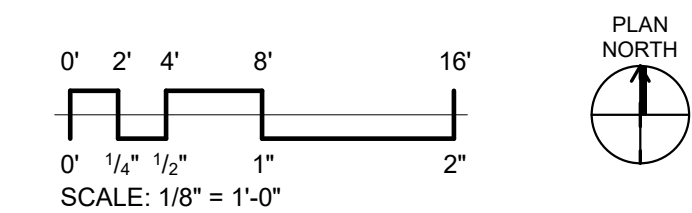

CITY OF EVANSVILLE  
 BUILDING ADDITION  
 15 OLD HWY 92  
 EVANSVILLE, WI

Project Status

2021.03.19	FOR CONSTRUCTION

PROJ. #: 20119-01

© SKETCHWORKS ARCHITECTURE 2021

ROOF PLAN

A104

FOR CONSTRUCTION

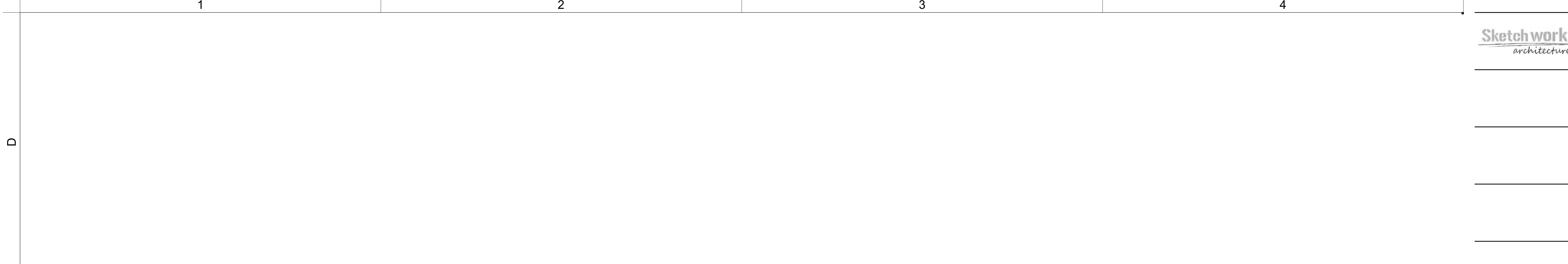

D

C

B

A

- EAVE HT WEST 119'-0"
- EAVE HT EAST 118'-9"
- OVERHANG 114'-0"
- T.O. MASONRY 103'-10"
- FIRST FLOOR 100'-0"
- TO FOOTING 96'-0"

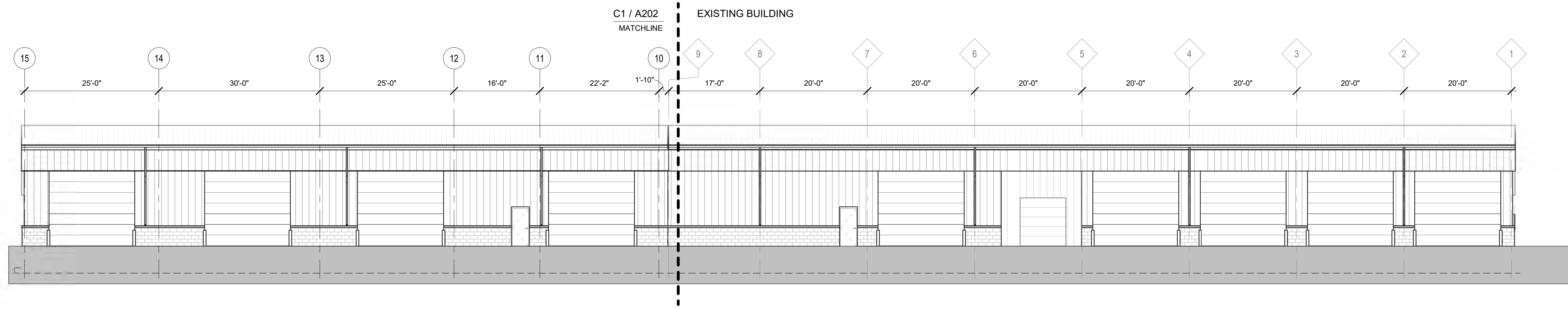

**B1** OVERALL EAST ELEVATION  
3/32" = 1'-0"

EXISTING BUILDING  
A1 / A202  
MATCHLINE

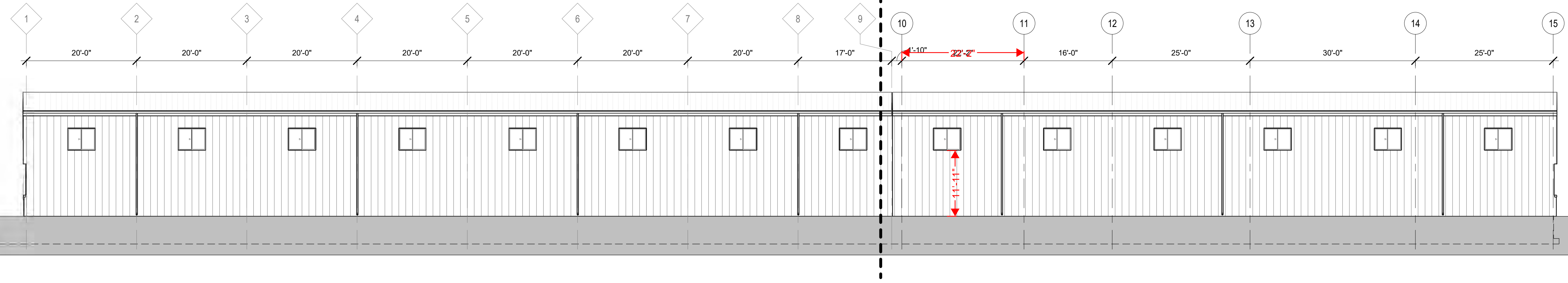

- EAVE HT WEST 119'-0"
- EAVE HT EAST 118'-9"
- OVERHANG 114'-0"
- T.O. MASONRY 103'-10"
- FIRST FLOOR 100'-0"
- TO FOOTING 96'-0"

**A1** OVERALL WEST ELEVATION  
3/32" = 1'-0"

**CITY OF EVANSVILLE**  
BUILDING ADDITION  
15 OLD HWY 92  
EVANSVILLE, WI

**Project Status**

2021.03.19	
FOR CONSTRUCTION	

PROJ. #: 20119-01

© SKETCHWORKS ARCHITECTURE 2021

**OVERALL EXTERIOR ELEVATIONS**

**FOR CONSTRUCTION**

**A201**

1

2

3

4

## EXTERIOR MATERIAL SCHEDULE

#	DESCRIPTION	MANUFACTURER	TYPE/STYLE	COLOR	HEIGHT	WIDTH	COMMENTS
1	CMU COPING	COUNTY MATERIALS	SPLITFACE	STEEL GRAY (18-348A)	16" NOM	8" NOM	4" DEEP BLOCK
2	METAL WALL PANEL	CUSTOM CAST STONE	SILLSL-SS	NATURAL	5"	5"	SEE DETAILS FOR PROFILE
3	METAL GUTTER	VP	-	COOL GRANITE GRAY	-	-	-
4	METAL ROOF	VP	STANDING SEAM	COOL ZINC GRAY	-	-	-
5	METAL DOWNSPOUT	VP	-	MATCH EXISTING	-	-	-
6	METAL DOWNSPOUT	VP	-	COOL GRANITE GRAY	-	-	-

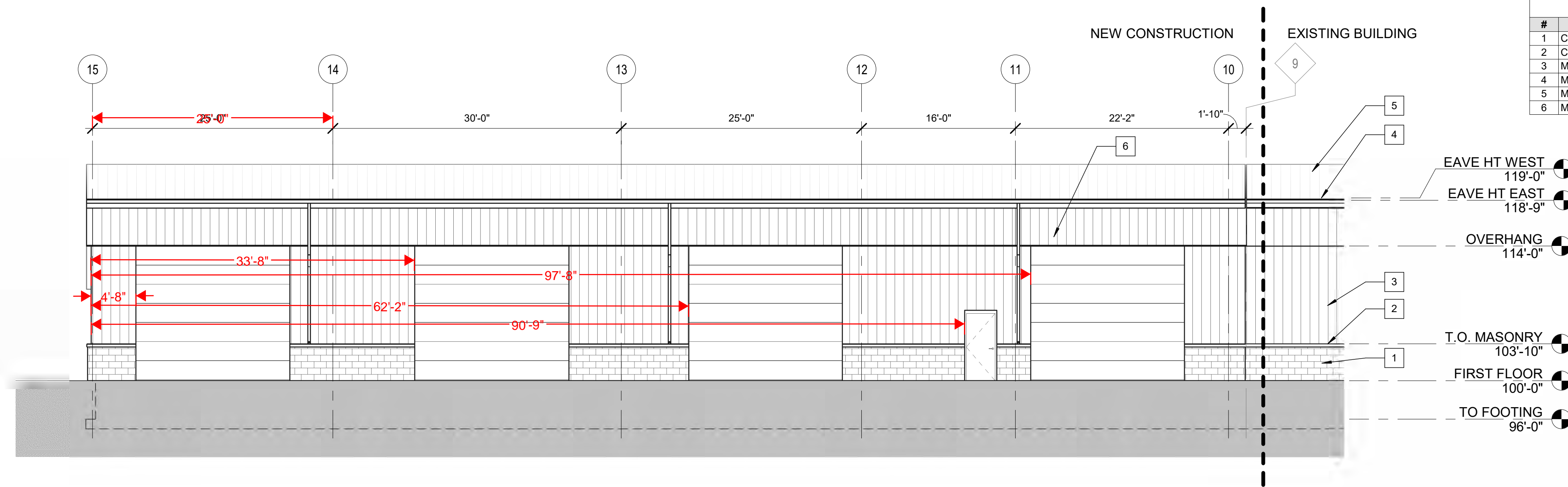

**C1** ENLARGED EAST ELEVATION  
1/8" = 1'-0"

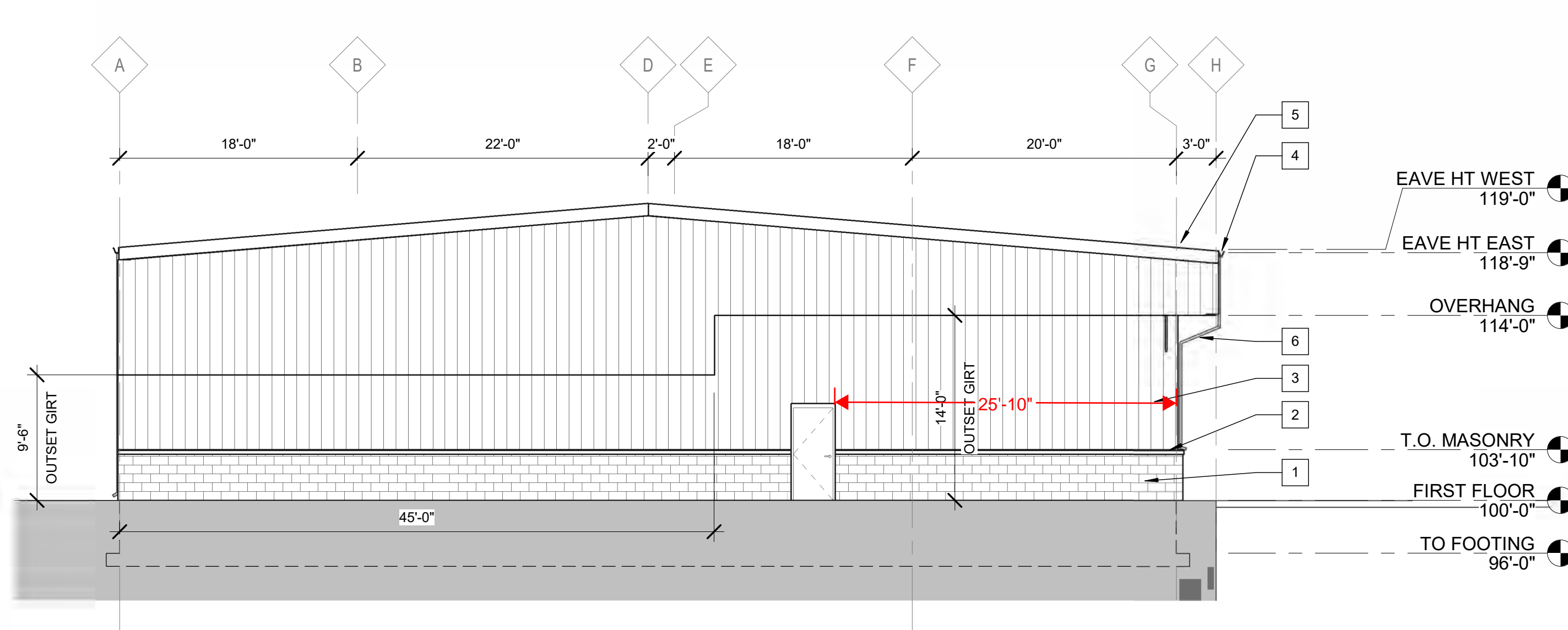

**B1** SOUTH ELEVATION  
1/8" = 1'-0"

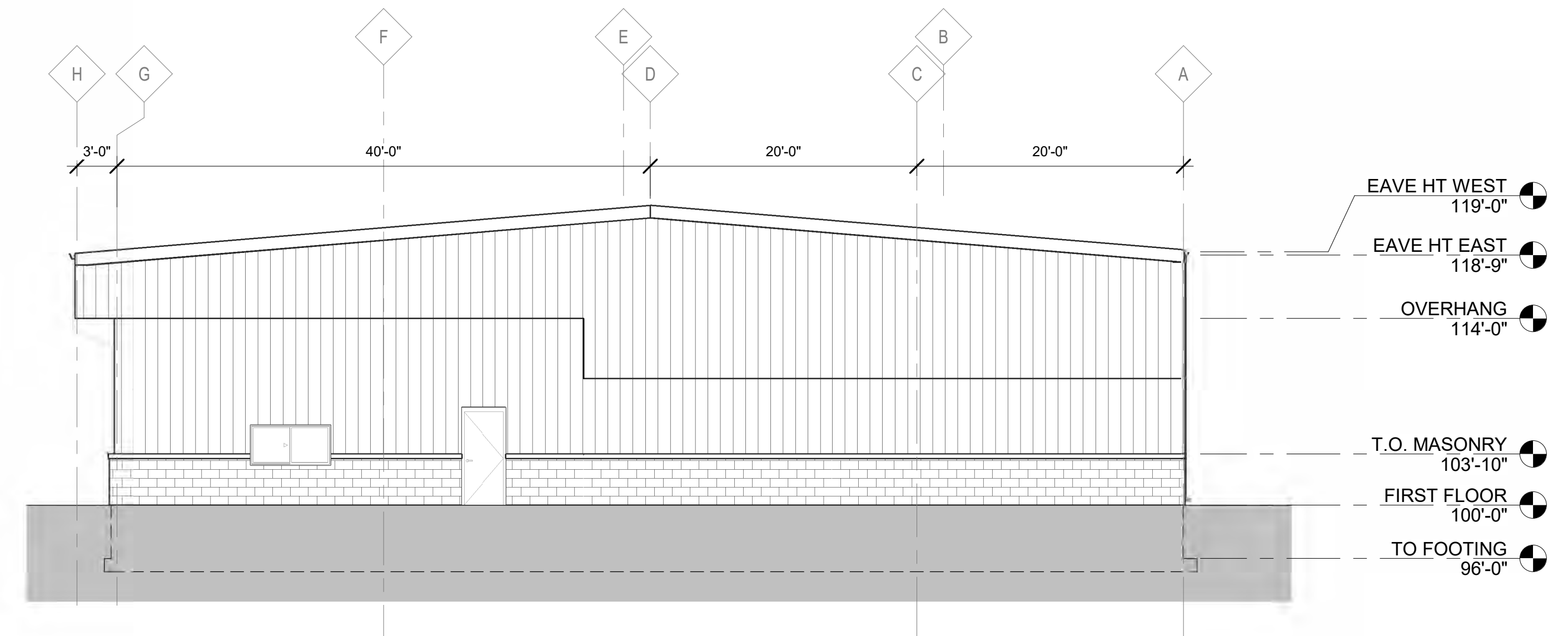

**B3** NORTH ELEVATION-EXISTING BUILDING  
1/8" = 1'-0"

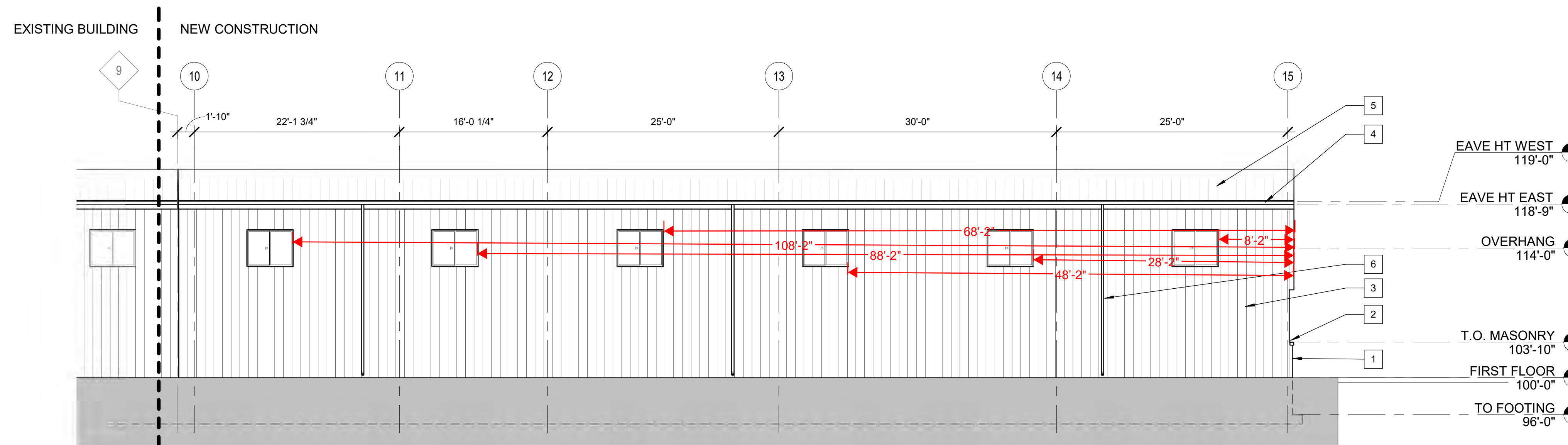

**A1** ENLARGED WEST ELEVATION  
1/8" = 1'-0"

CITY OF EVANSVILLE

BUILDING ADDITION

15 OLD HWY 92  
EVANSVILLE, WI

## Project Status

2021.03.19	FOR CONSTRUCTION

PROJ. #: 20119-01

© SKETCHWORKS  
ARCHITECTURE 2021ENLARGED  
EXTERIOR  
ELEVATIONS

A202

FOR CONSTRUCTION

D

C

B

A

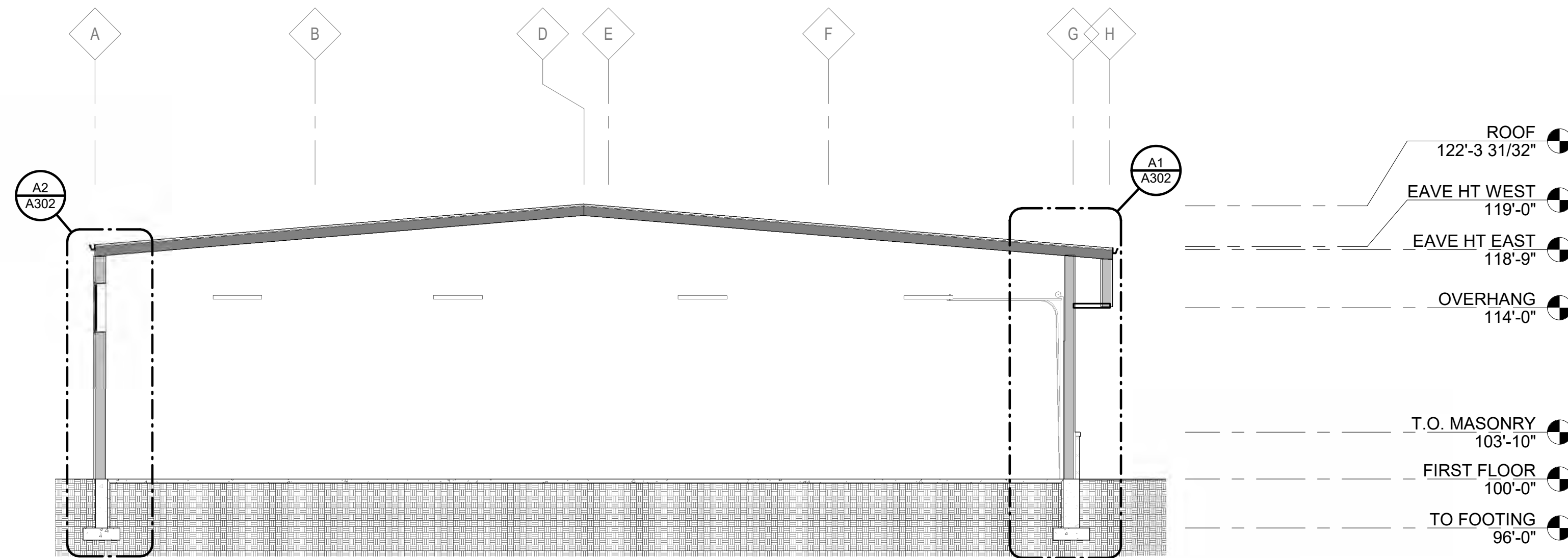

**B2** BUILDING SECTION 1  
1/8" = 1'-0"

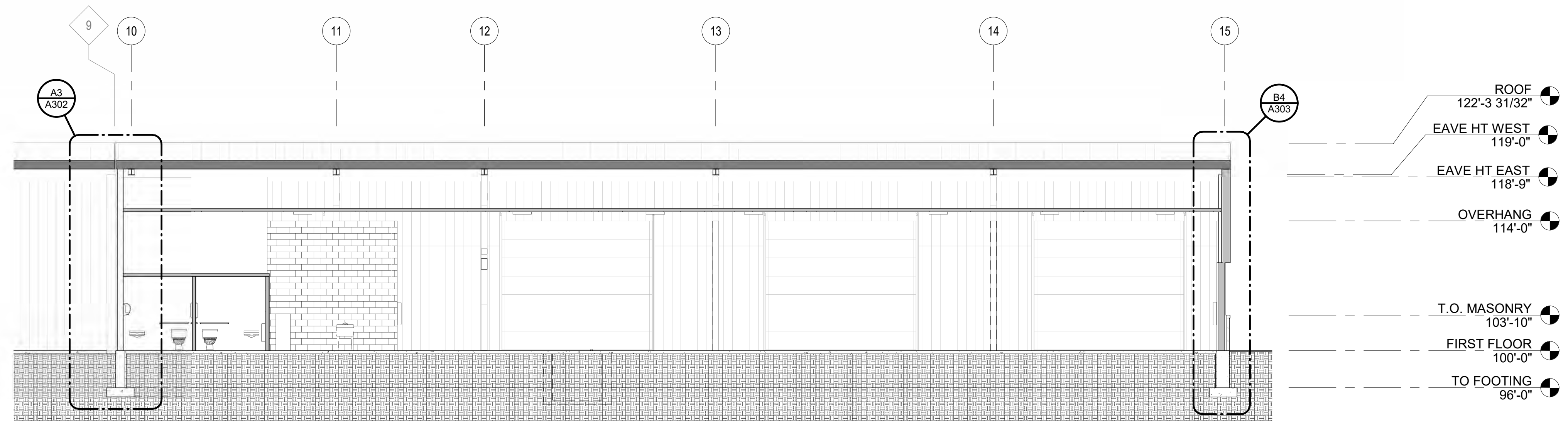

**A2** BUILDING SECTION 2  
1/8" = 1'-0"

**CITY OF EVANSVILLE**  
**BUILDING ADDITION**  
15 OLD HWY 92  
EVANSVILLE, WI

**Project Status**  
2021.03.19 FOR CONSTRUCTION

PROJ. #: 20119-01

© SKETCHWORKS ARCHITECTURE 2021

**BUILDING SECTIONS**

**A301**

**FOR CONSTRUCTION**



D  
C  
B  
A

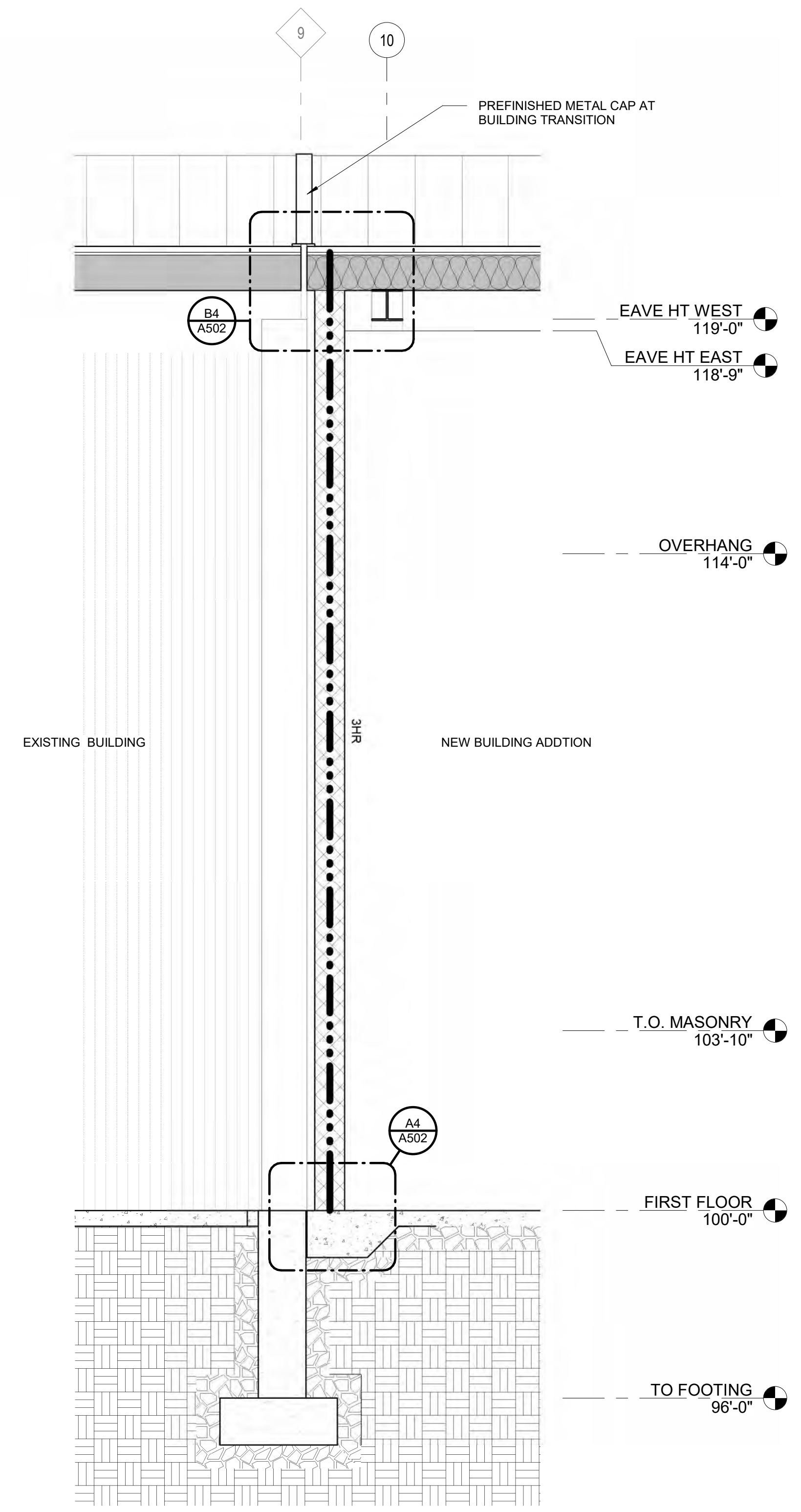
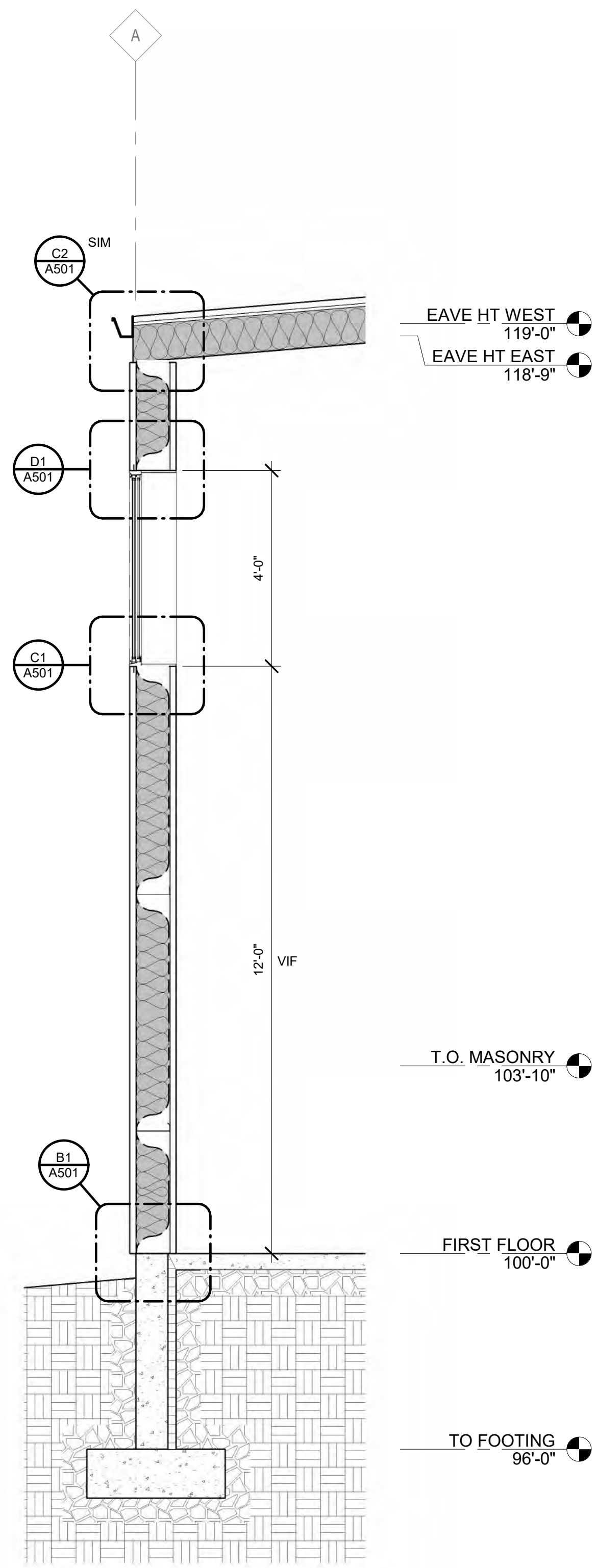
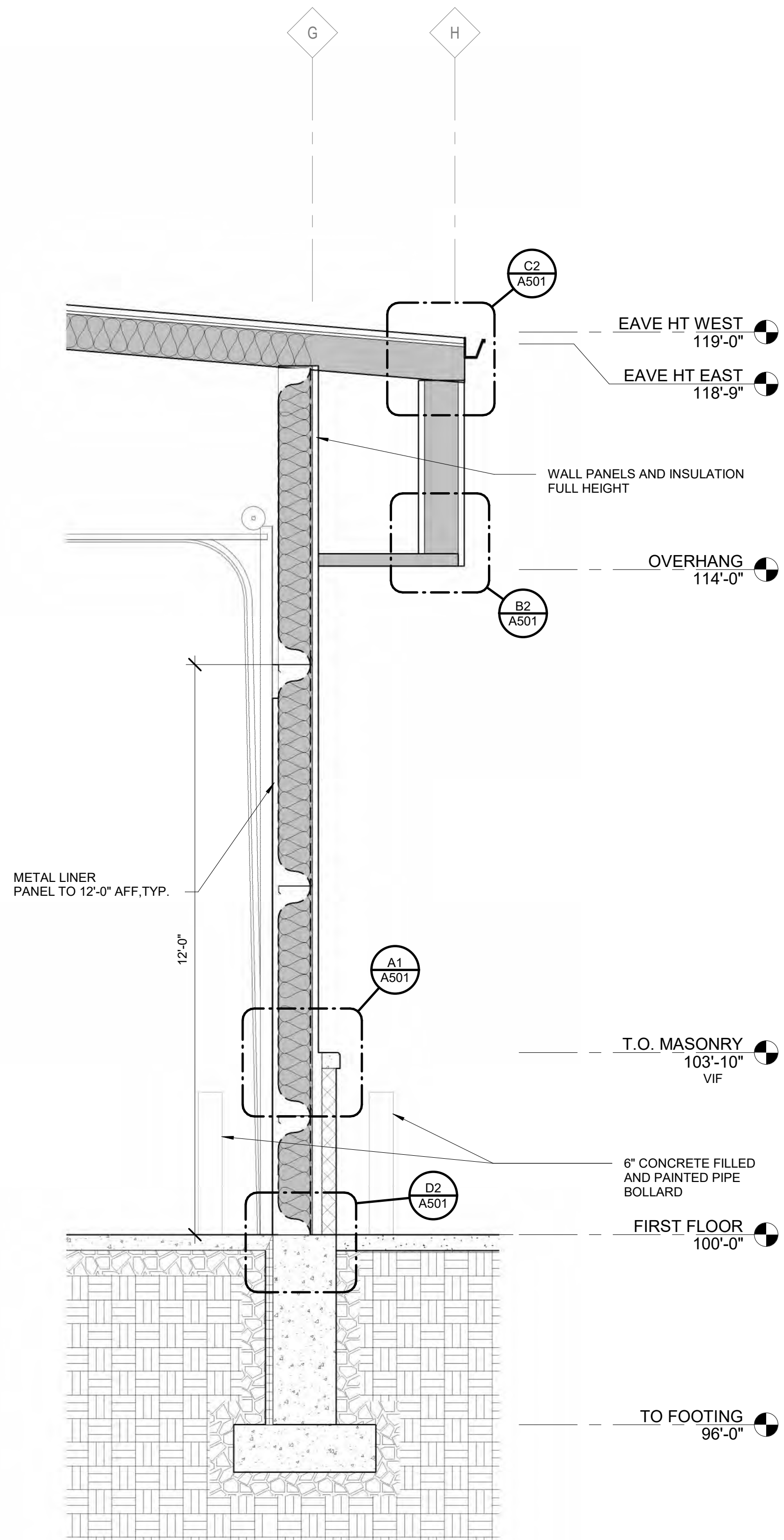

**A1** EAST WALL  
1/2" = 1'-0"

**A2** WEST WALL  
1/2" = 1'-0"

**A3** 3 HOUR FIRE BARRIER WALL  
1/2" = 1'-0"

**CITY OF EVANSVILLE**  
BUILDING ADDITION  
15 OLD HWY 92  
EVANSVILLE, WI

**Project Status**

2021.03.19	FOR CONSTRUCTION

PROJ. #: 20119-01

© SKETCHWORKS ARCHITECTURE 2021

**WALL SECTIONS**

**A302**

**FOR CONSTRUCTION**

D

C

B

A

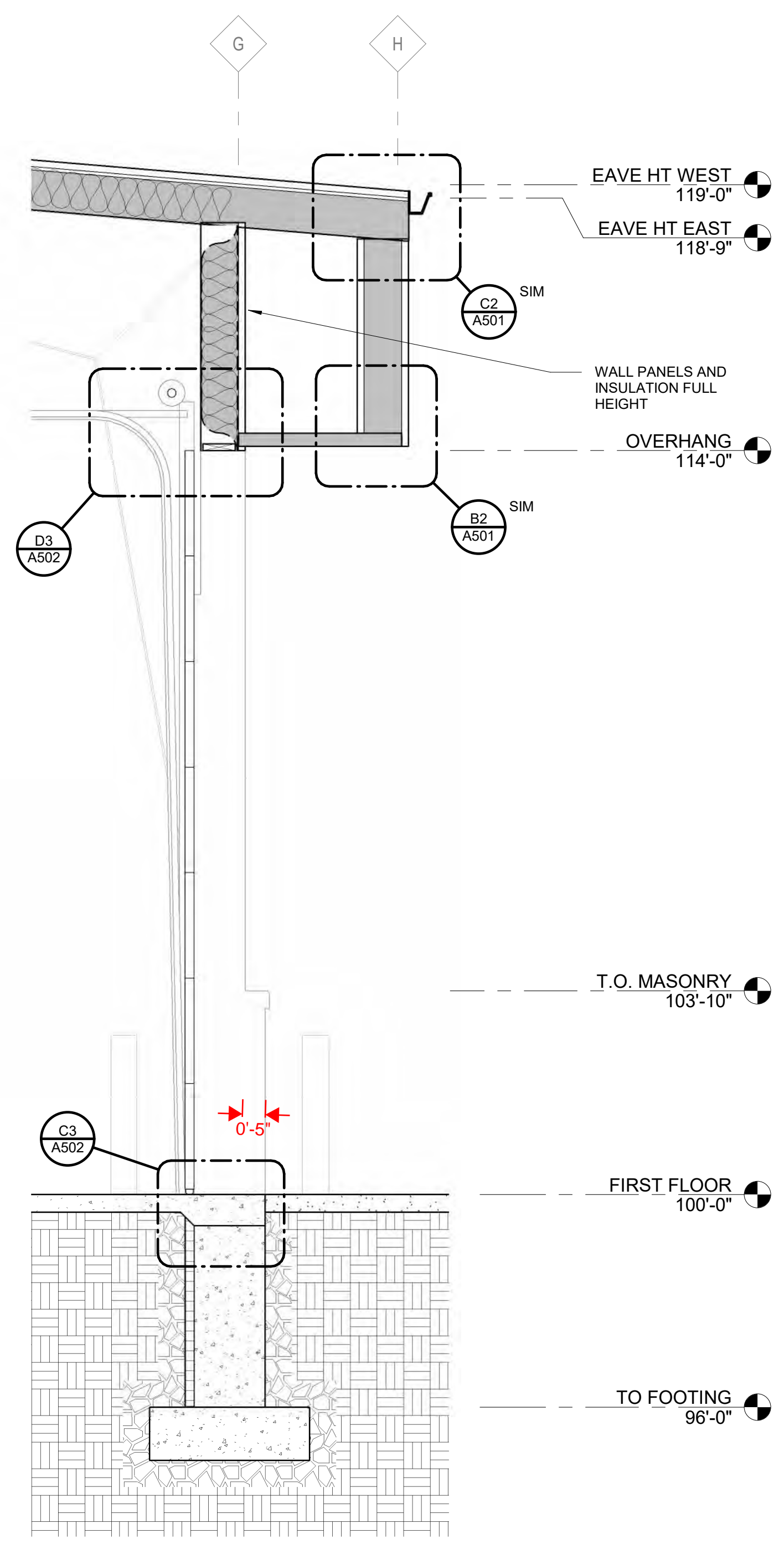

**B2** EAST WALL OVERHEAD DOOR  
1/2" = 1'-0"

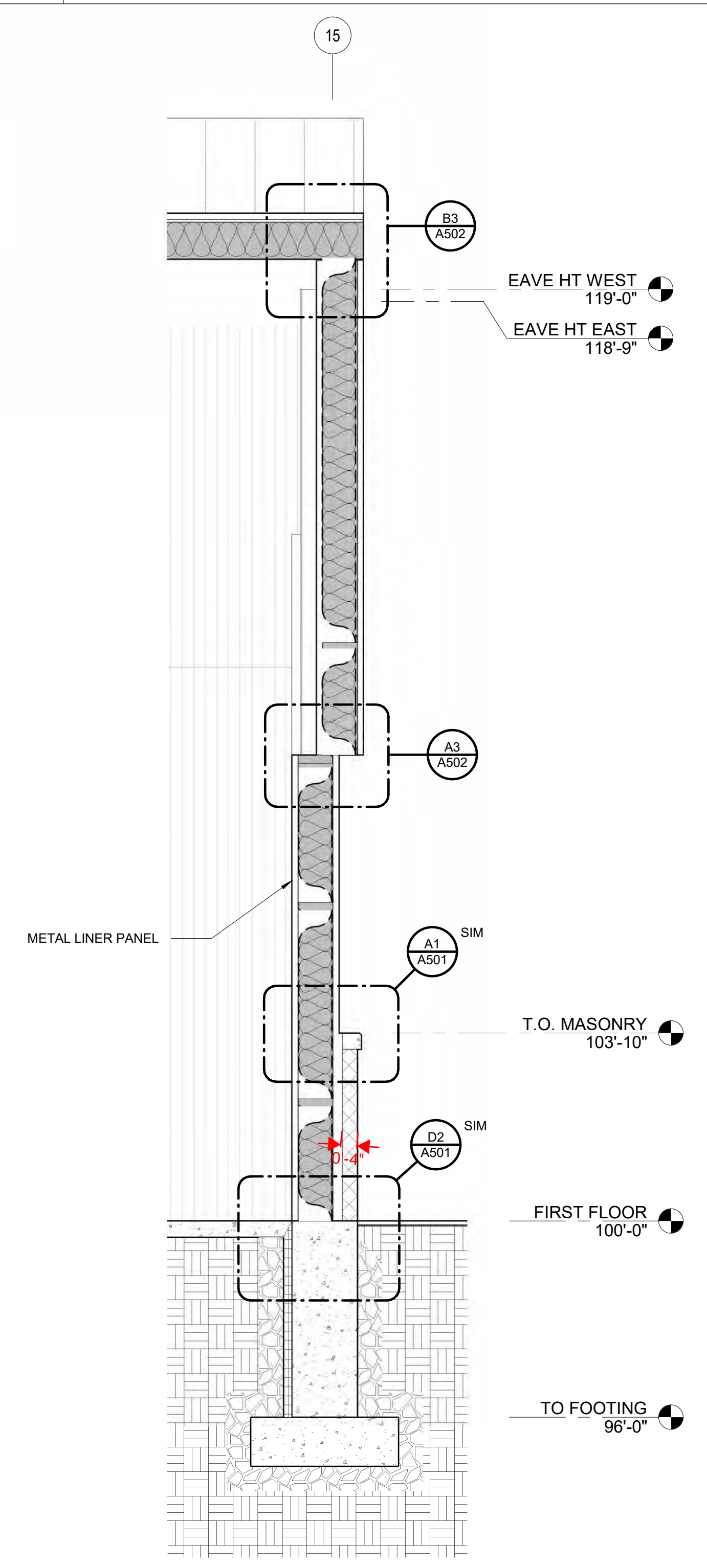

**B4** SOUTH WALL  
1/2" = 1'-0"

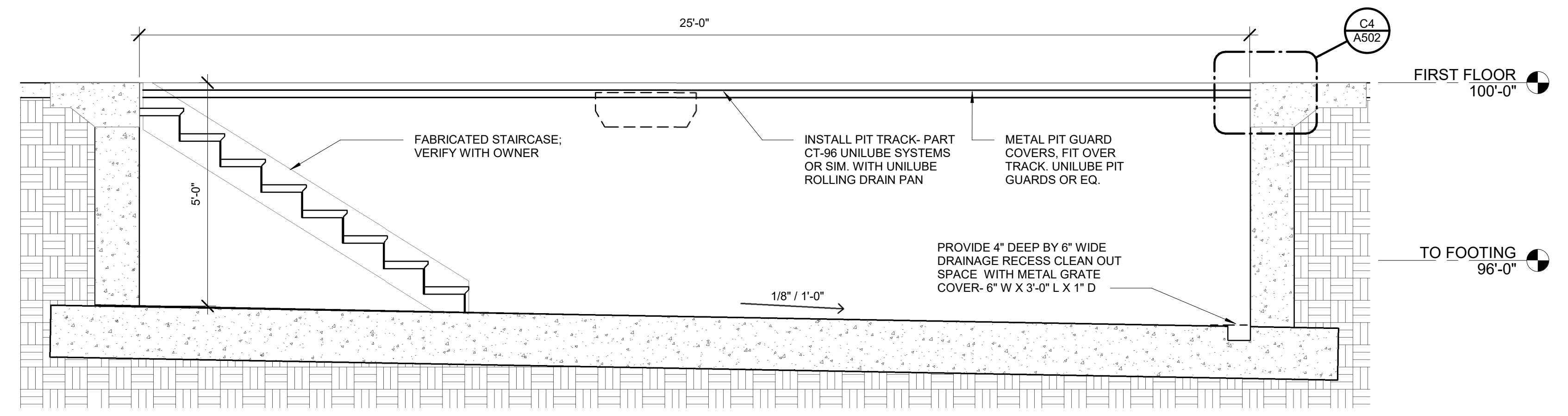

**A2** MAINTENANCE PIT  
1/2" = 1'-0"

**CITY OF EVANSVILLE**  
BUILDING ADDITION  
15 OLD HWY 92  
EVANSVILLE, WI

**Project Status**  
2021.03.19 FOR CONSTRUCTION

PROJ. #: 20119-01

© SKETCHWORKS ARCHITECTURE 2021

**WALL SECTIONS**

**A303**

**FOR CONSTRUCTION**



**GENERAL PLAN NOTES:**

- A. ALL DIMENSIONS SHOWN ARE NOMINAL. REFER TO DETAILS FOR EXACT PARTITION TYPE SIZES. ALL DIMENSIONS ARE FACE OF FRAME TO FACE OF FRAME.
- B. THE THICKNESS OF TILE, WOOD BASE, WAINSCOTING, TRIM AND SIMILAR APPLIED FINISHES ARE NOT INCLUDED IN ROOM DIMENSIONS. THOSE ELEMENTS WILL BE DIMENSIONED IN THE DETAIL.
- C. FIELD VERIFY OPENING AND ROOM SIZES FOR FINISH MATERIALS AND CABINETS PRIOR TO ORDERING AND INSTALLATION.
- D. PROVIDE SOLID WOOD BLOCKING FOR CABINETS, SHELVE, TOILET ACCESSORIES, AND TELEVISION MOUNTS.
- E. PROVIDE SOLID WOOD BLOCKING AT ALL GRAB BAR LOCATIONS PER ANSI A117.1 2009
- F. ALL FINISHES, APPLIANCES, EQUIPMENT, CABINET LAYOUTS AND ACCESSORIES TO BE APPROVED BY ARCHITECT/DESIGNER PRIOR TO INSTALLATION.
- G. SEE A002 FOR TYPICAL FIXTURE MOUNTING HEIGHTS. ALL EXPOSED PLUMBING BELOW SINKS TO BE WRAPPED IN THERMAL BARRIERS.

**# PLAN KEYNOTES:**

- 1 SEALED CONCRETE FLOOR
- 2 PROVIDE FRP ON OUTSIDE OF WALL, FULL HEIGHT

**TOILET ROOM**

**# ACCESSORIES SCHEDULE:**

- 1 FLOOR MOUNTED TOILET
- 2 VANITY SINK
- 3 WALL MOUNTED MIRROR
- 4 WALL MOUNTED LIQUID SOAP DISPENSER
- 5 RECESSED PAPER TOWEL AND WASTE RECEPTACLE
- 6 SANITARY NAPKIN WASTE RECEPTACLE
- 7 TOILET PAPER DISPENSER
- 8 42" LONG HORIZONTAL GRAB BAR & 18" LONG VERTICAL GRAB BAR
- 9 36" LONG HORIZONTAL GRAB BAR
- 10 ROBE HOOK
- 11 FLUSH MOUNT PAPER TOWEL AND WASTE RECEPTACLE

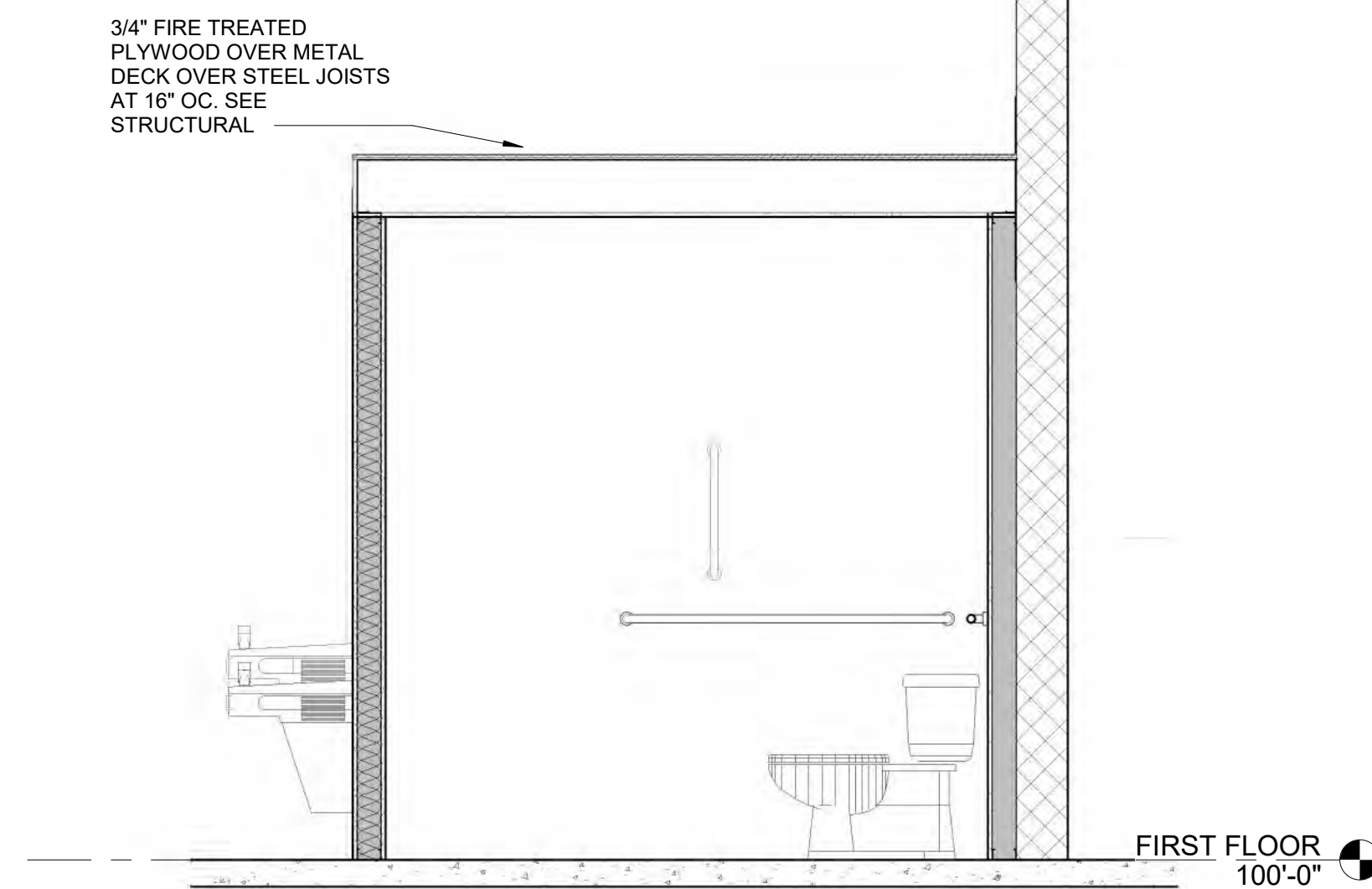

**A1** SECTION @ RESTROOMS  
1/2" = 1'-0"

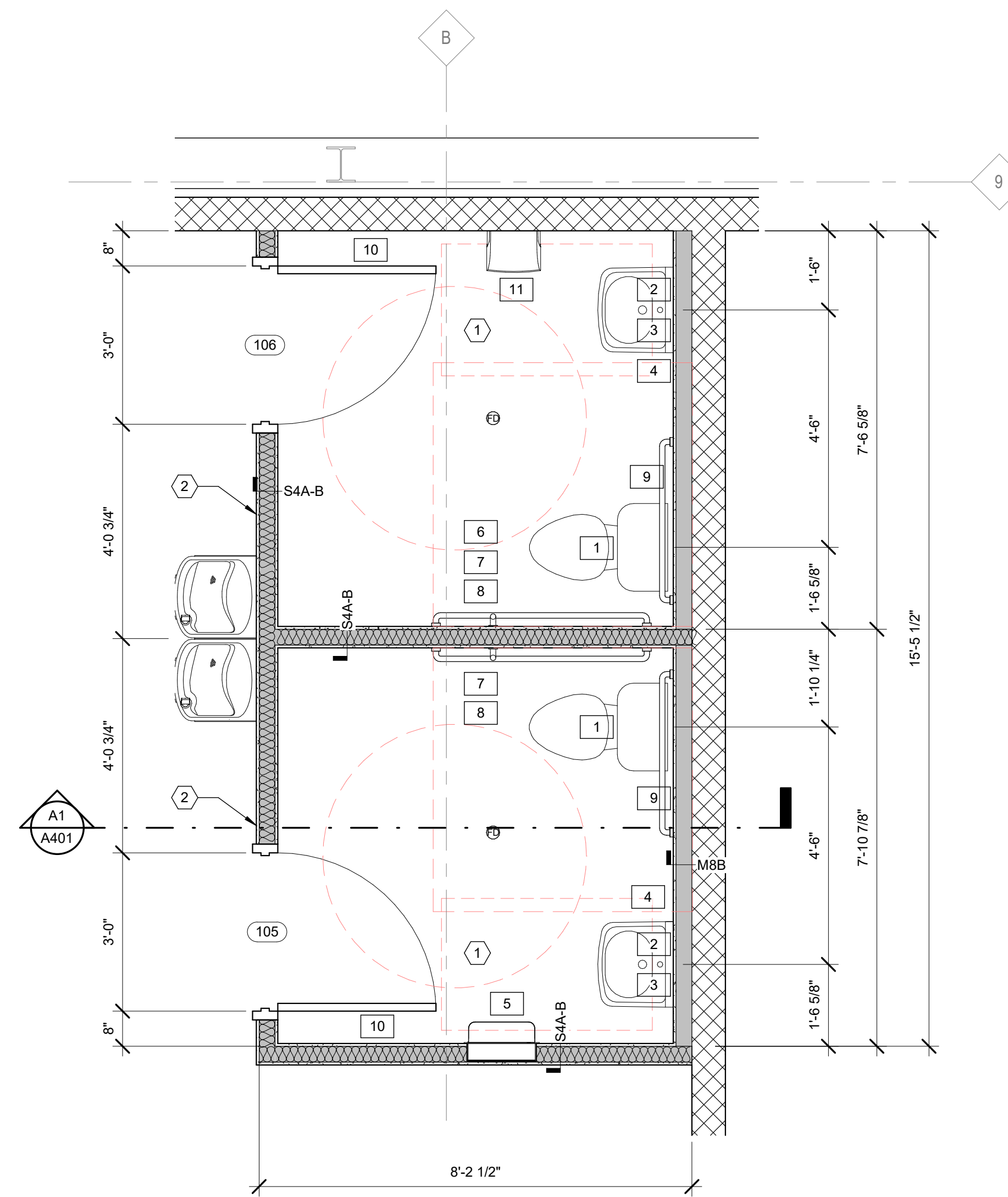

**A3** RESTROOM PLANS  
1/2" = 1'-0"

**CITY OF EVANSVILLE**  
**BUILDING ADDITION**  
**15 OLD HWY 92**  
**EVANSVILLE, WI**

**Project Status**

2021.03.19		FOR CONSTRUCTION

PROJ. #: 20119-01

© SKETCHWORKS ARCHITECTURE 2021

**ENLARGED FLOOR PLANS**

**A401**

1

2

3

4

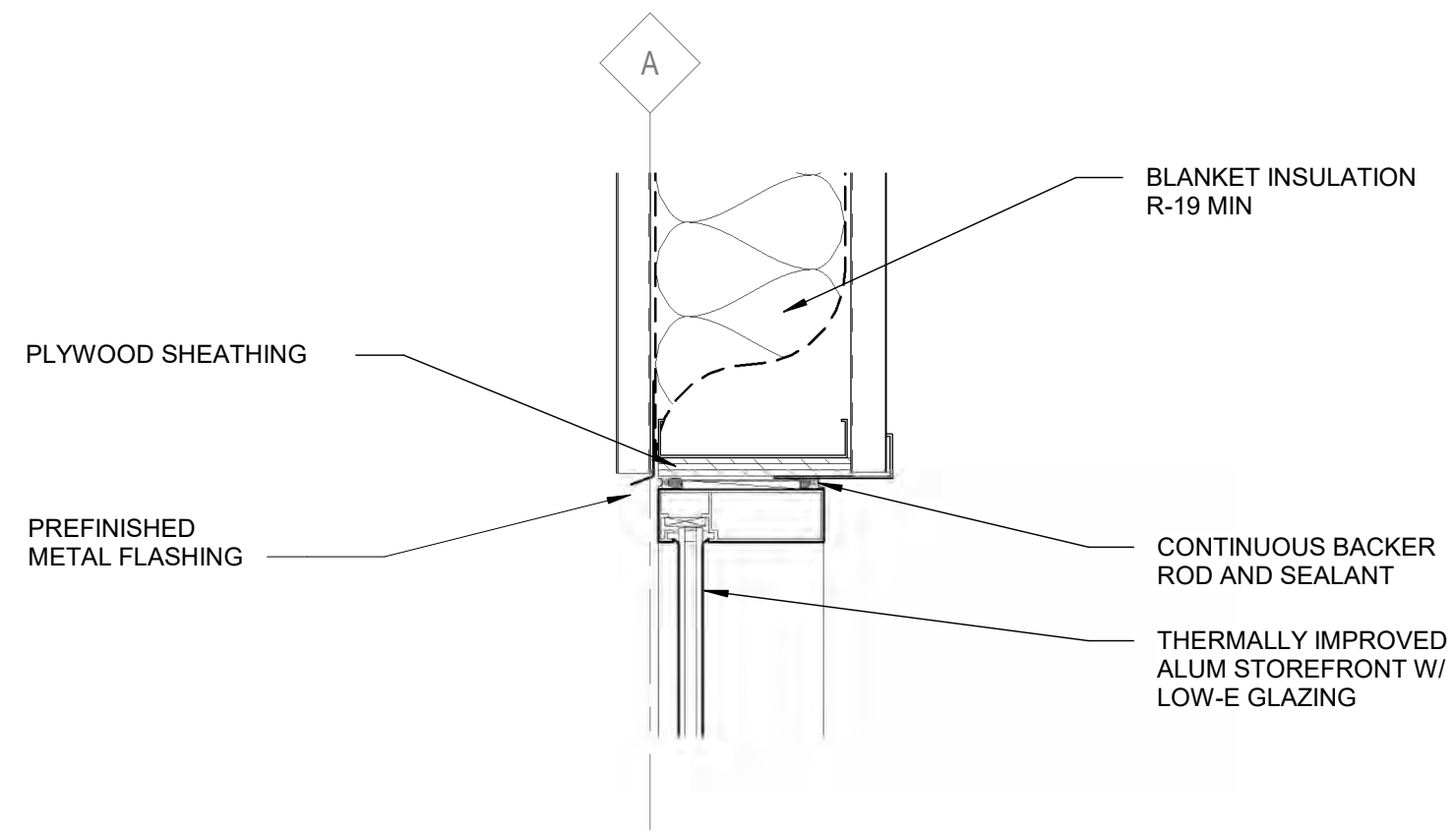

**D1** WEST WALL WINDOW HEAD  
1 1/2" = 1'-0"

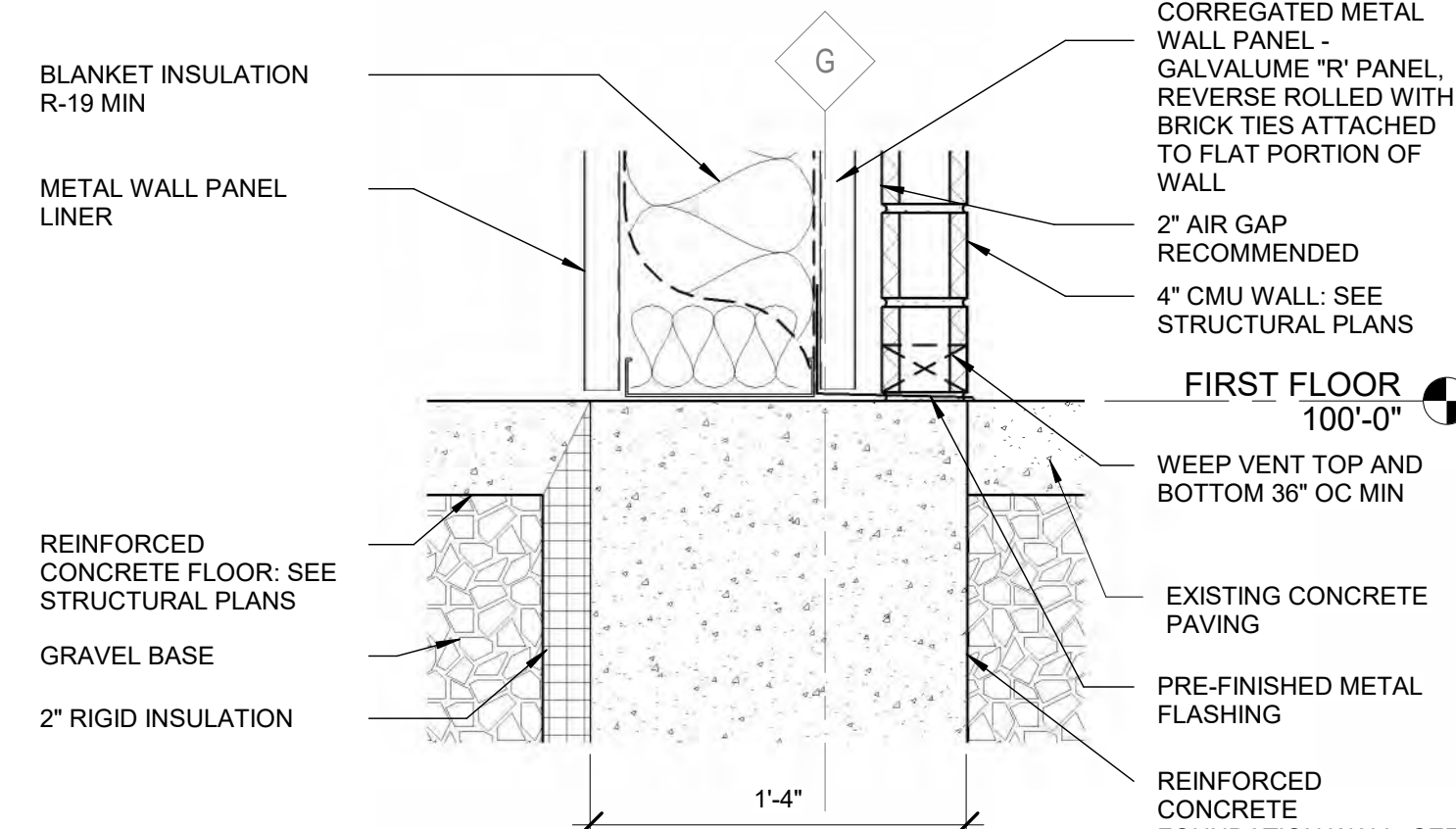

**D2** EAST WALL AT FOUNDATION  
1 1/2" = 1'-0"

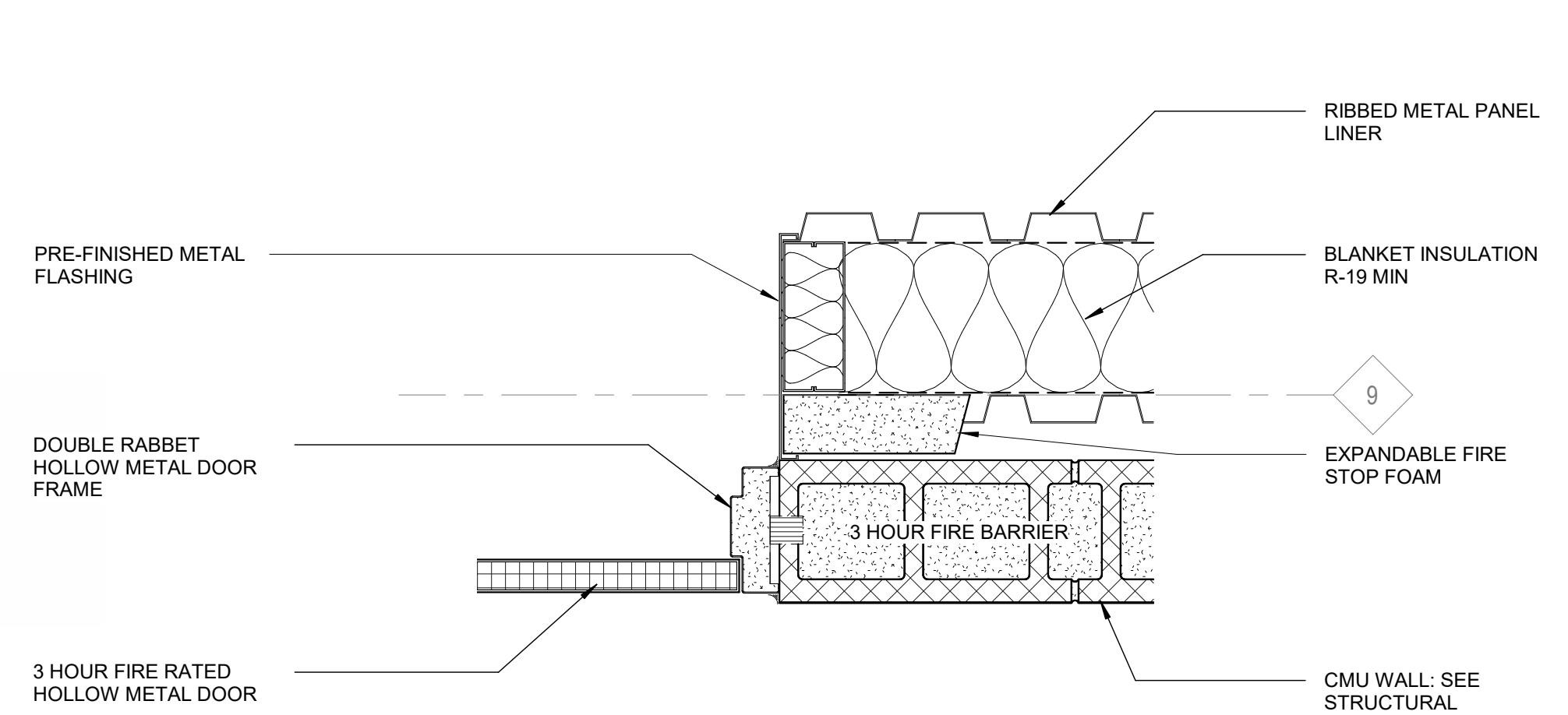

**C3** FIRE DOOR JAMB  
1 1/2" = 1'-0"

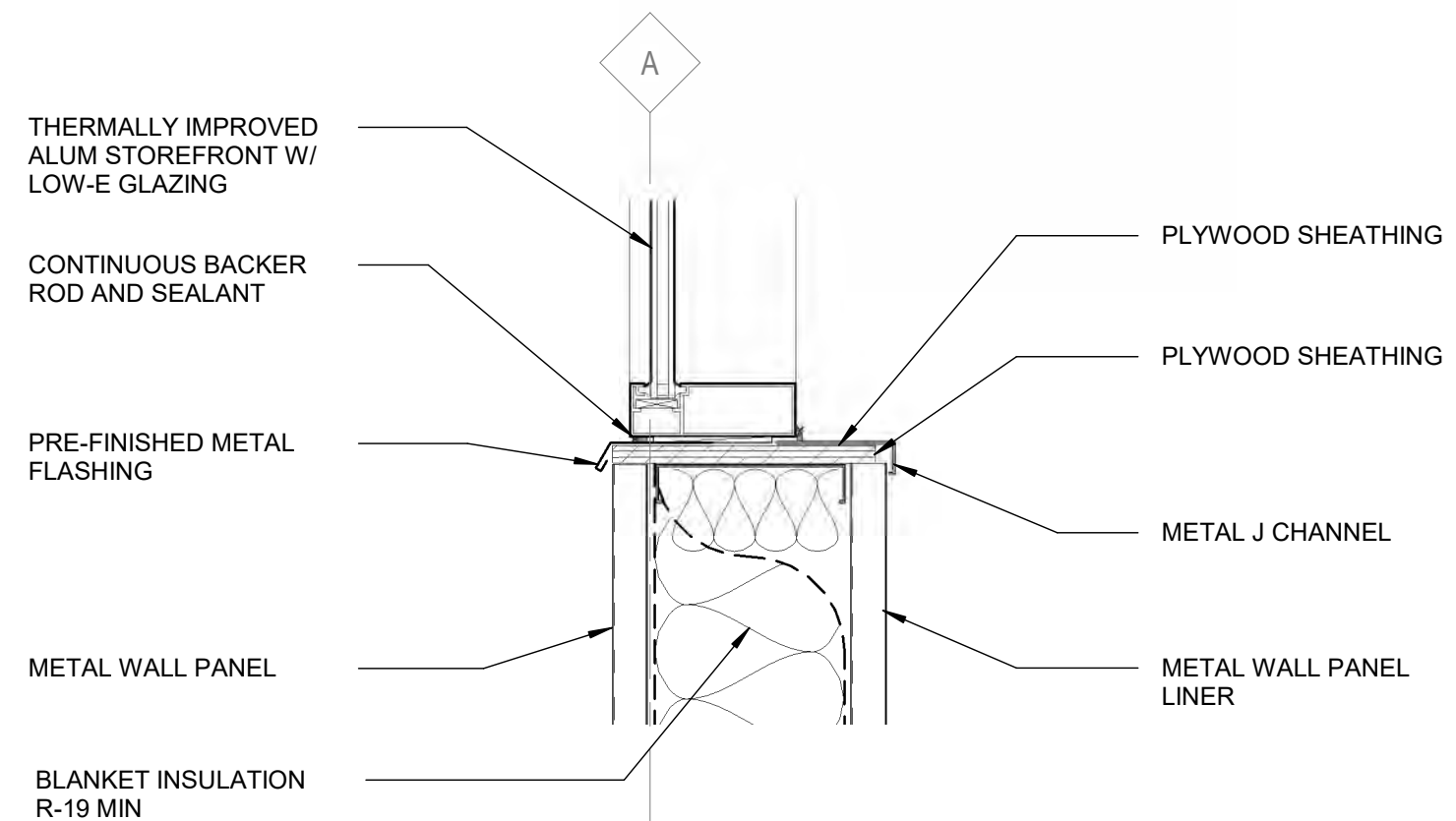

**C1** WEST WALL WINDOW SILL  
1 1/2" = 1'-0"

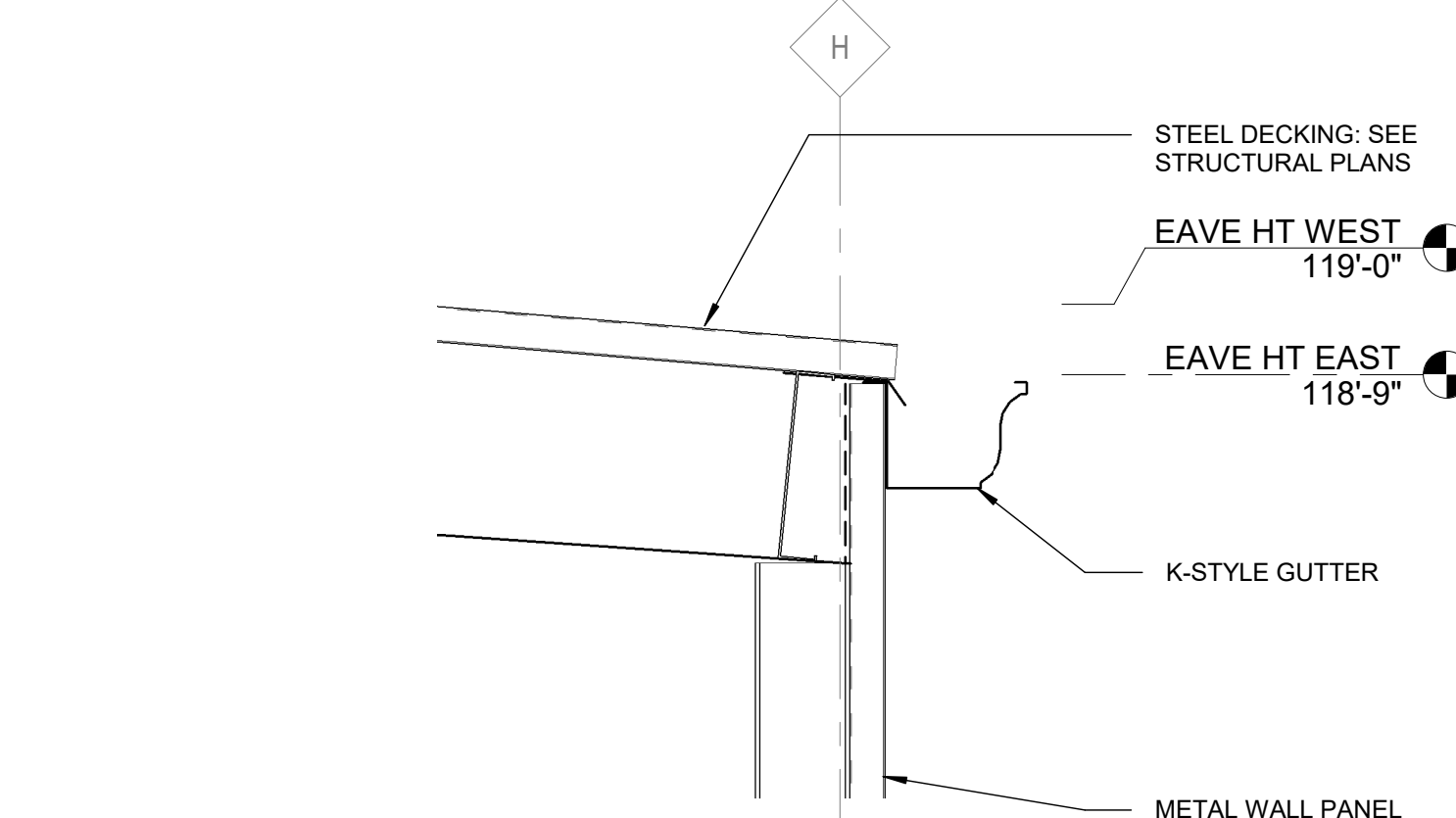

**C2** ROOF EAVE (TYPICAL)  
1 1/2" = 1'-0"

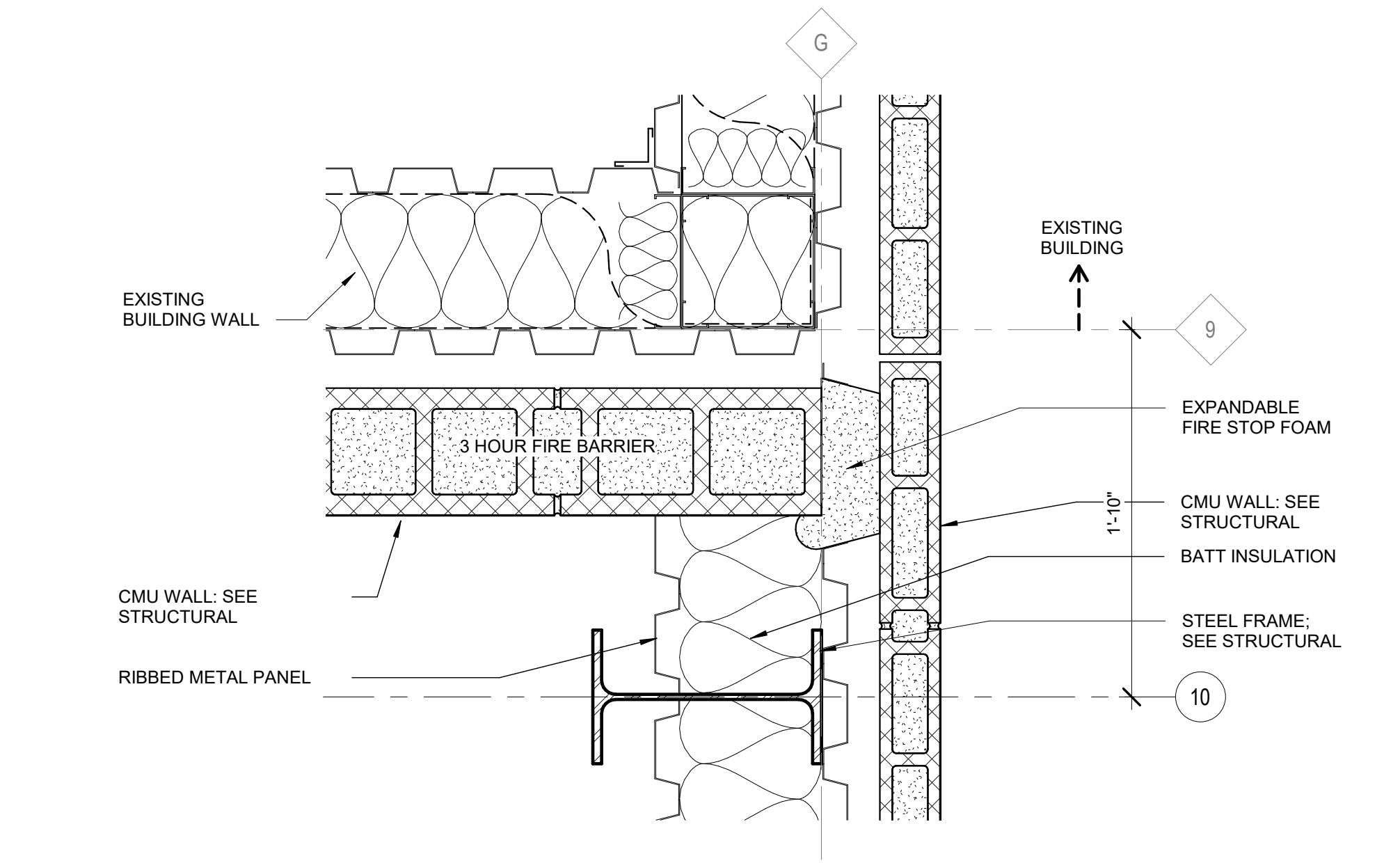

**B3** FIRE WALL CORNER  
1 1/2" = 1'-0"

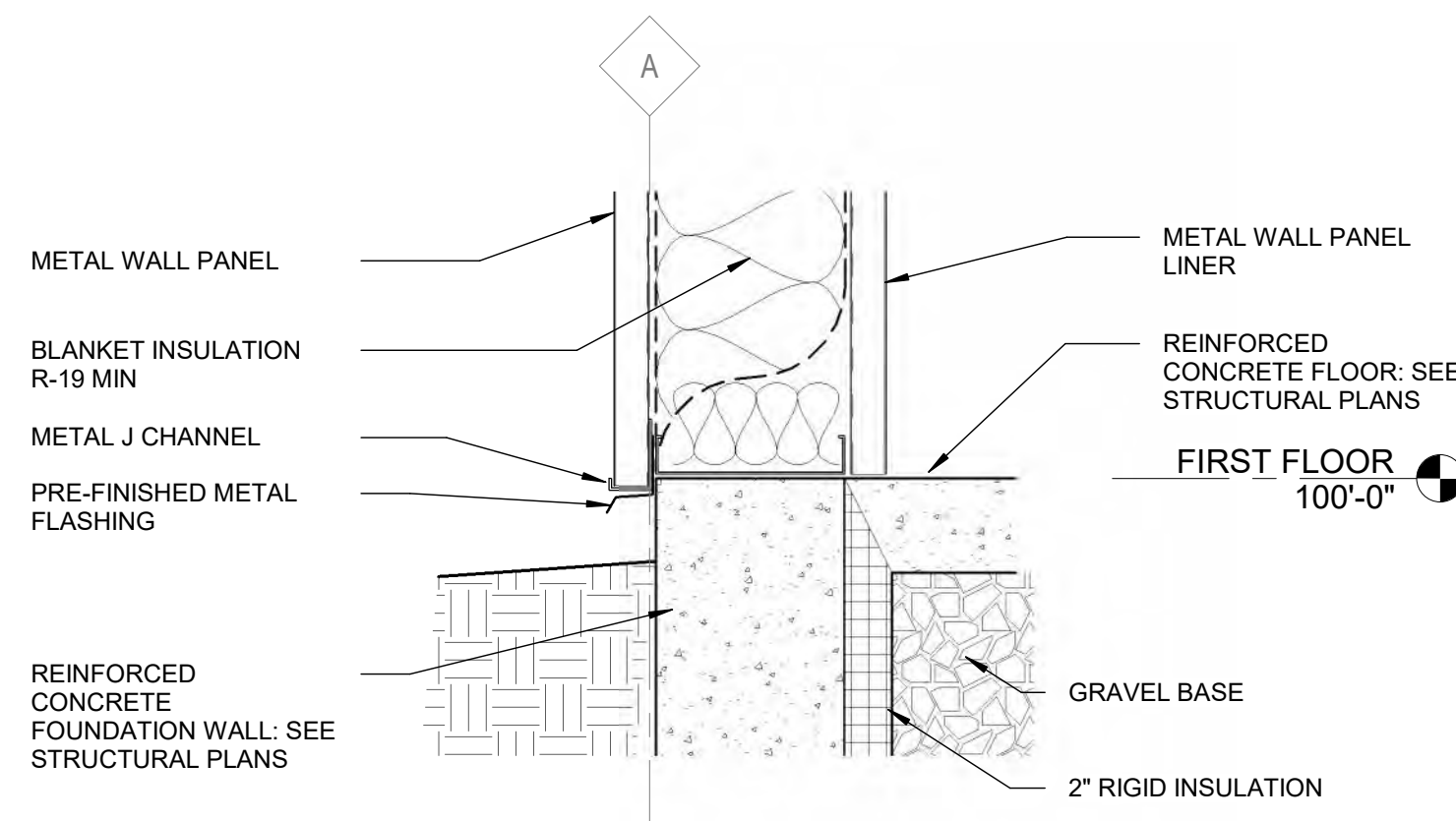

**B1** WEST WALL AT FOUNDATION  
1 1/2" = 1'-0"

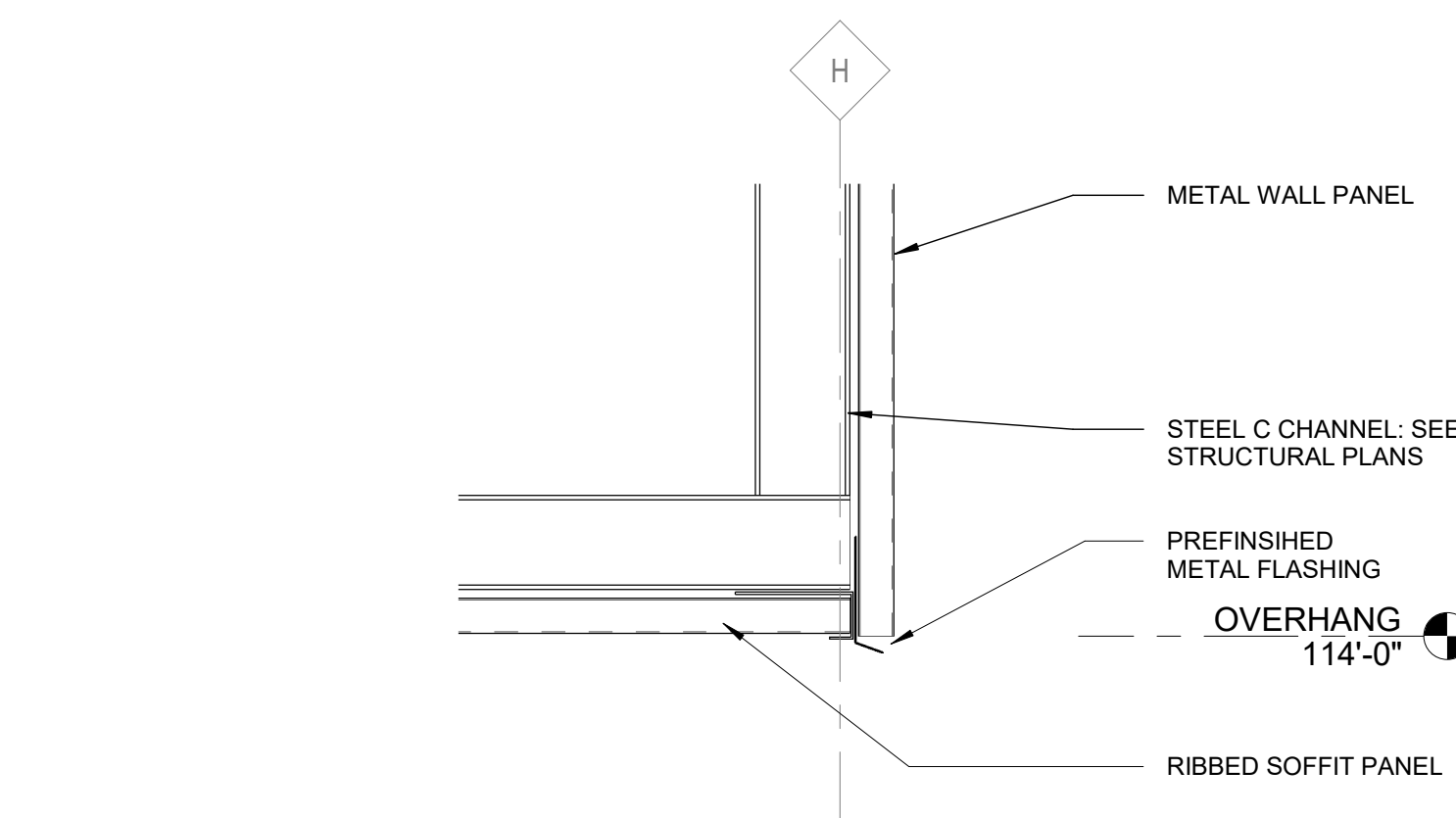

**B2** EAST WALL - Callout 1  
1 1/2" = 1'-0"

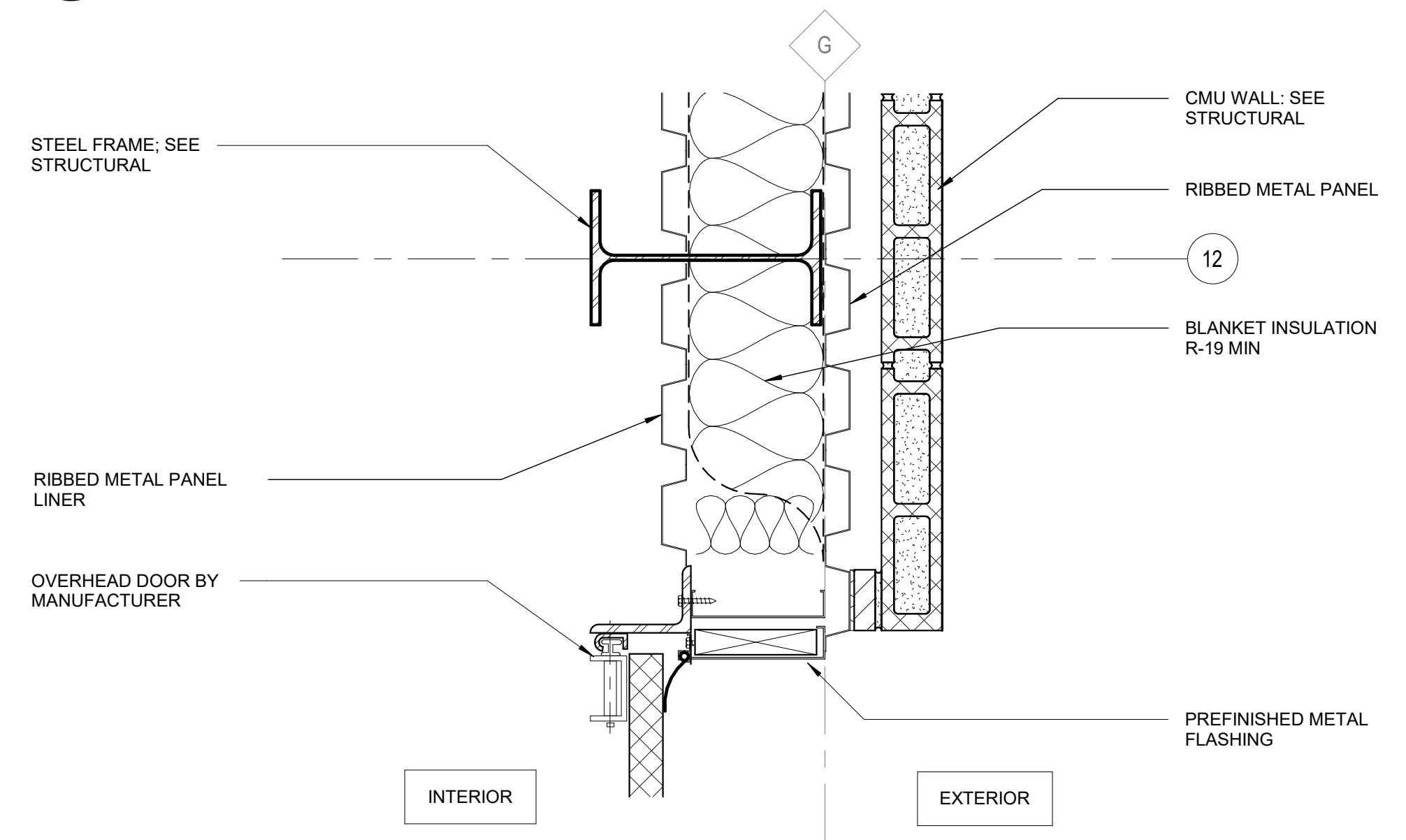

**A3** OVERHEAD DOOR JAMB  
1 1/2" = 1'-0"

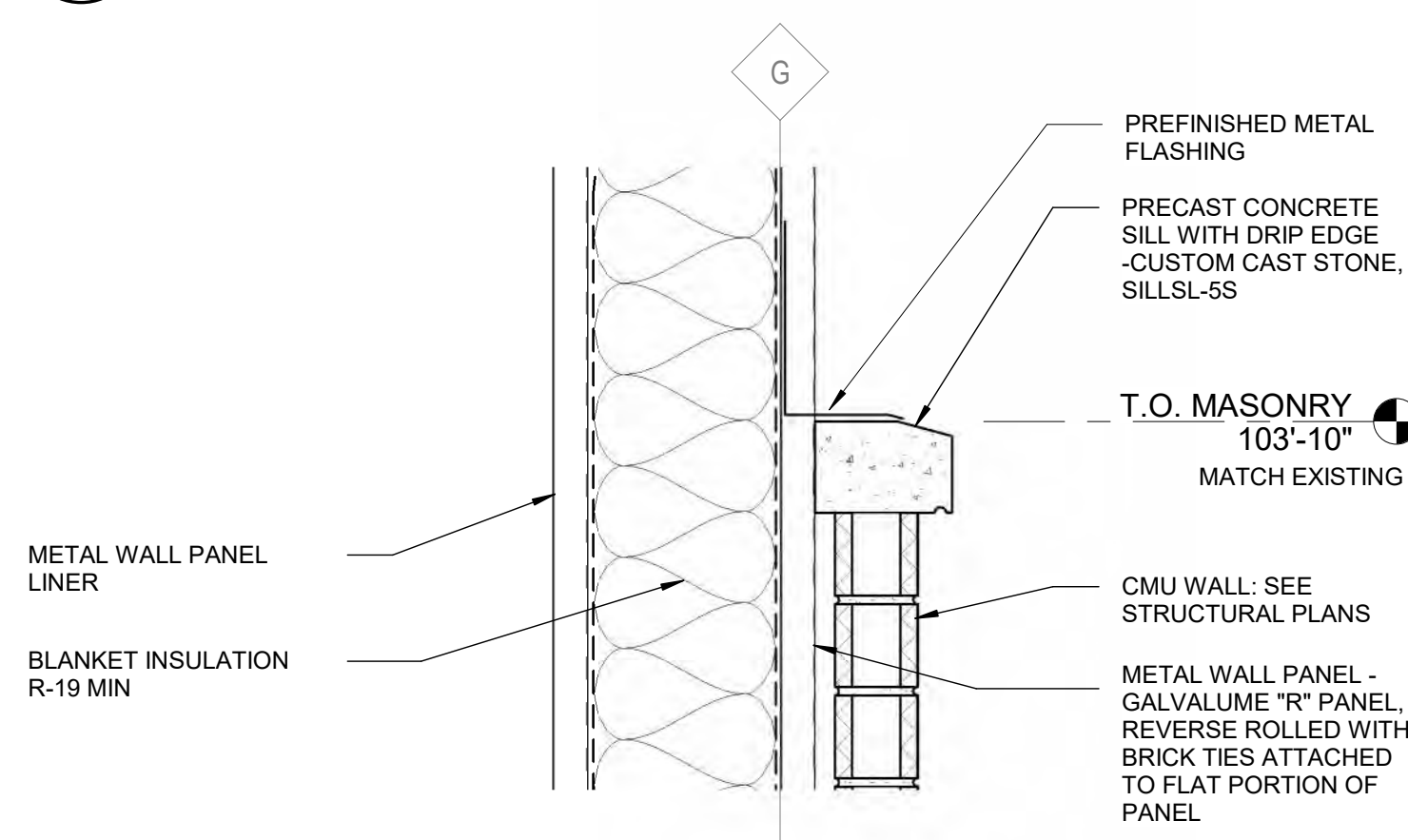

**A1** MASONRY LEDGE (TYPICAL)  
1 1/2" = 1'-0"

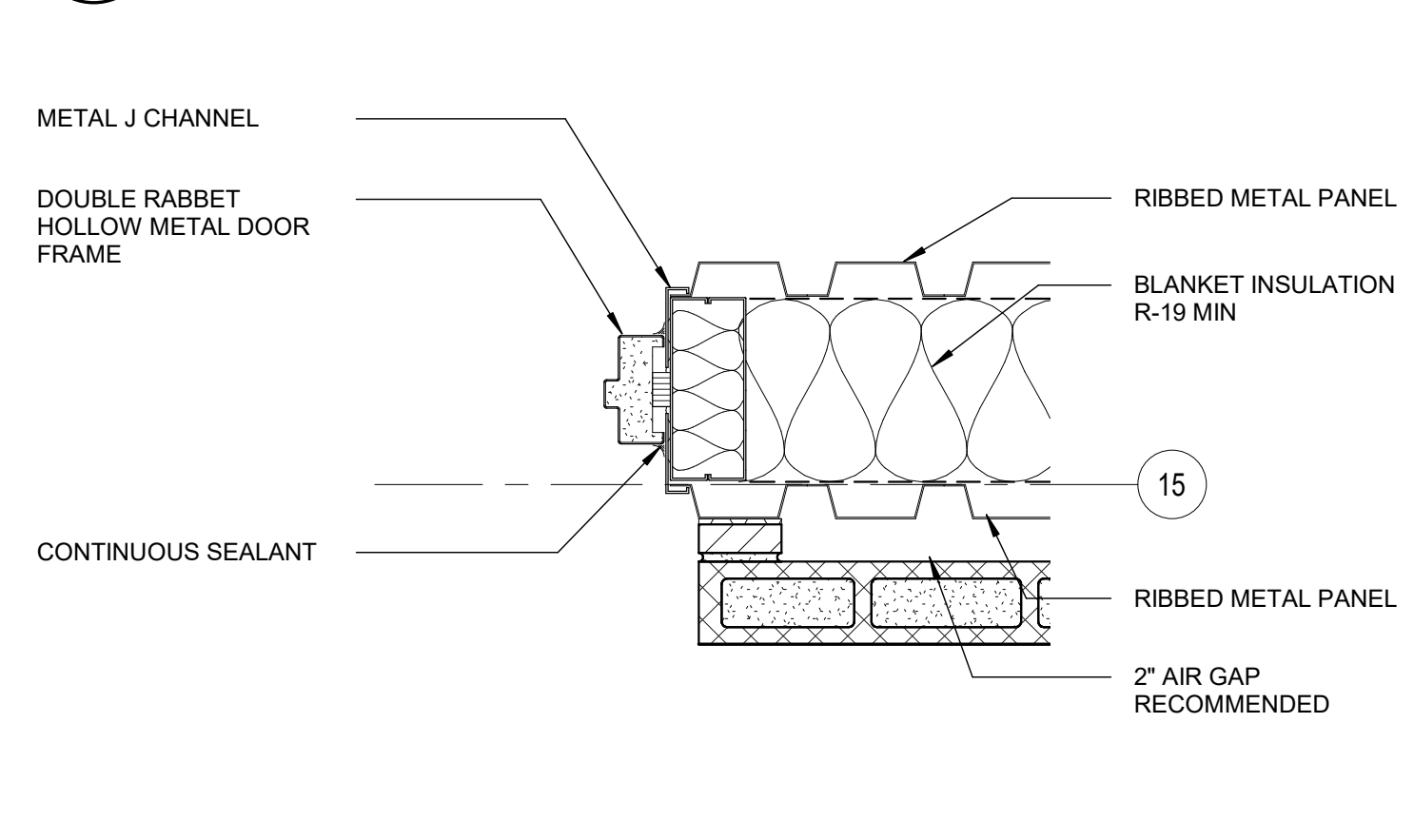

**A2** EXTERIOR DOOR JAMB  
1 1/2" = 1'-0"

**Project Status**

2021.03.19	FOR CONSTRUCTION

PROJ. #: 20119-01

© SKETCHWORKS ARCHITECTURE 2020

**PLAN AND SECTION DETAILS**

**A501**

**FOR CONSTRUCTION**



1

2

3

4

D

C

B

A

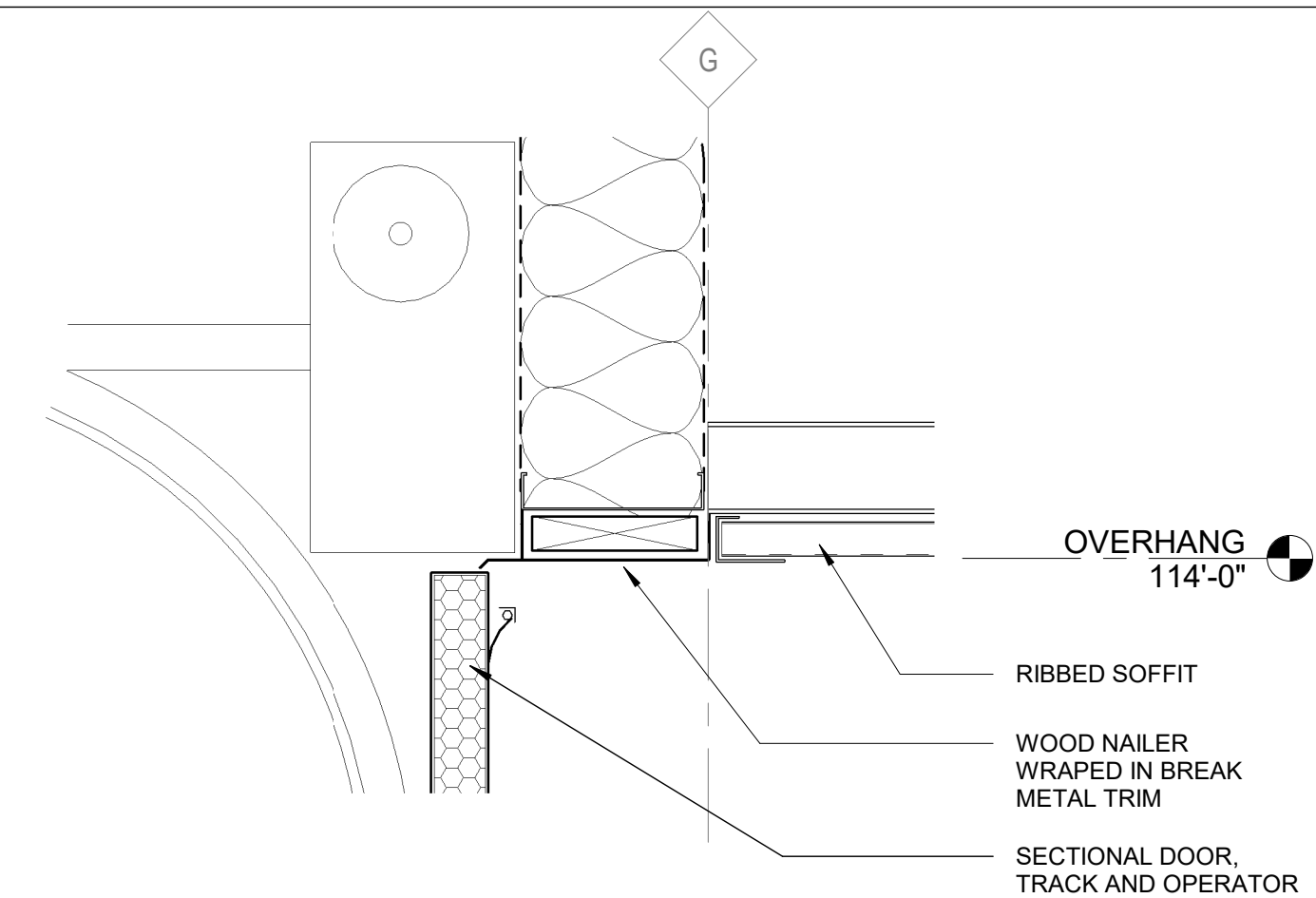

**D3** OVERHEAD DOOR HEAD (TYPICAL)  
1 1/2" = 1'-0"

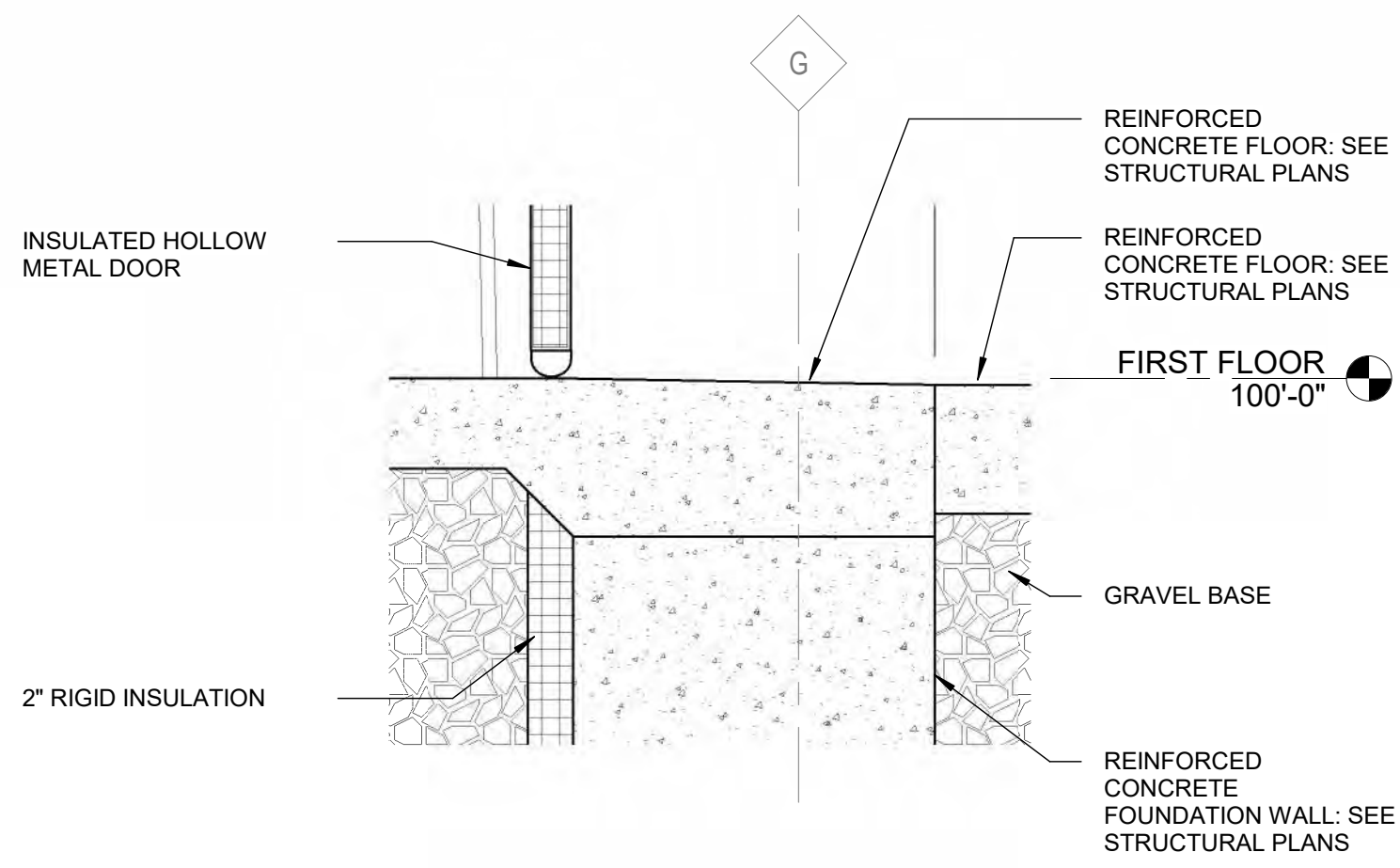

**C3** OVERHEAD DOOR SILL (TYPICAL)  
1 1/2" = 1'-0"

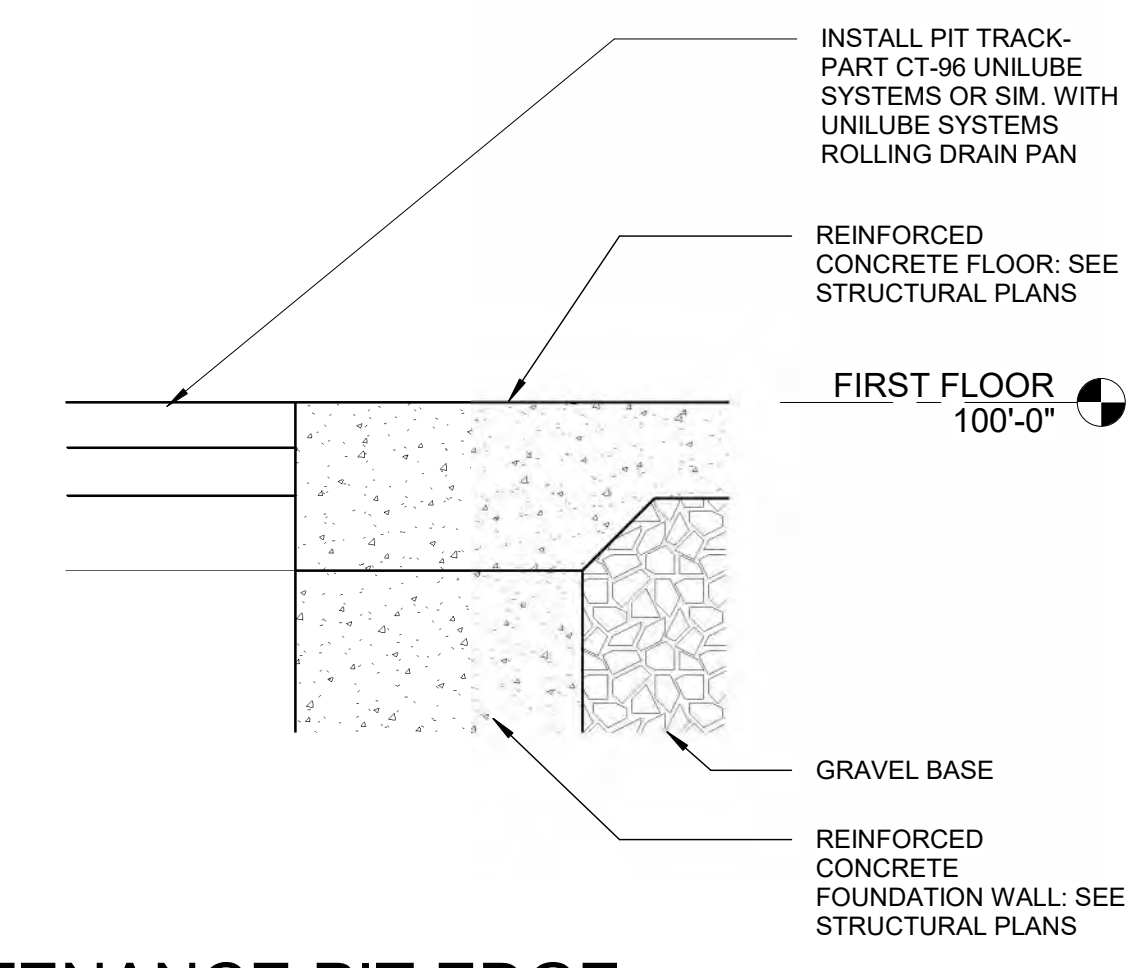

**C4** MAINTENANCE PIT EDGE  
1 1/2" = 1'-0"

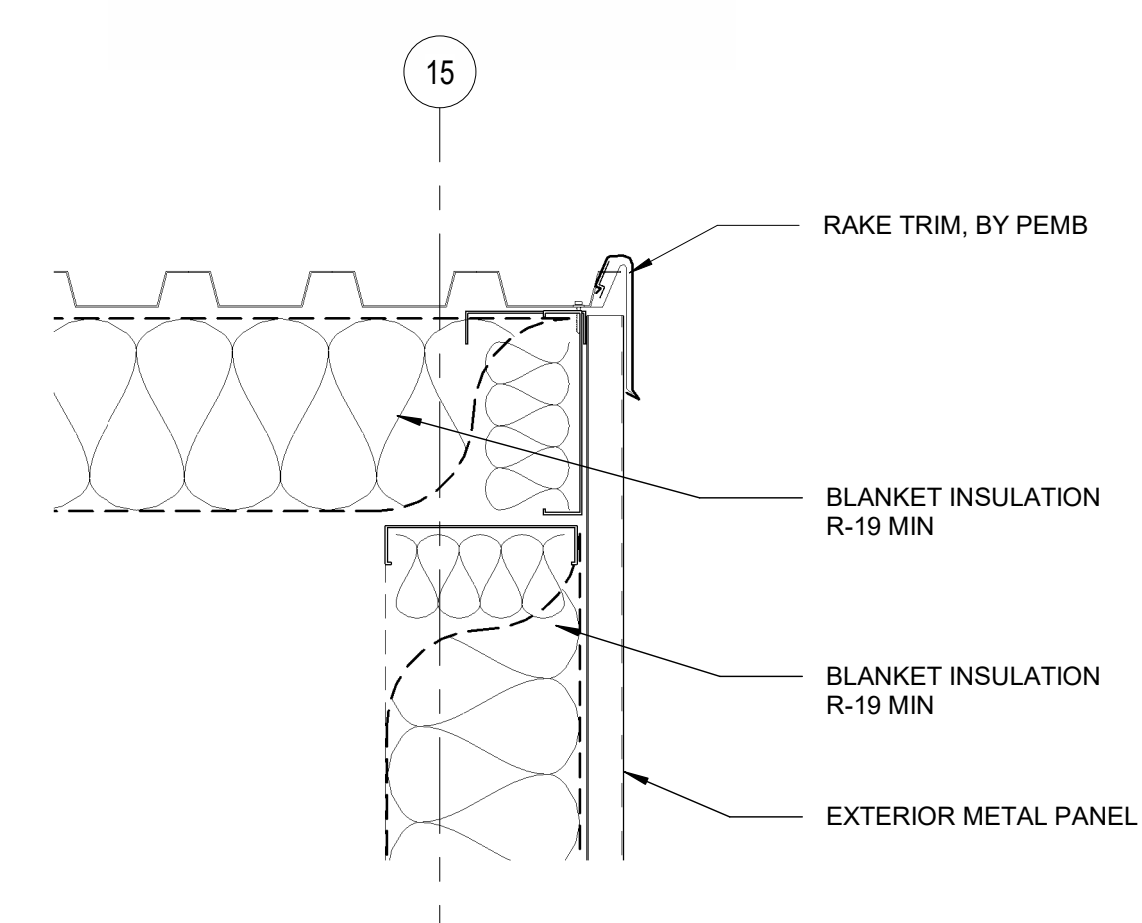

**B3** SOUTH WALL AT ROOF  
1 1/2" = 1'-0"

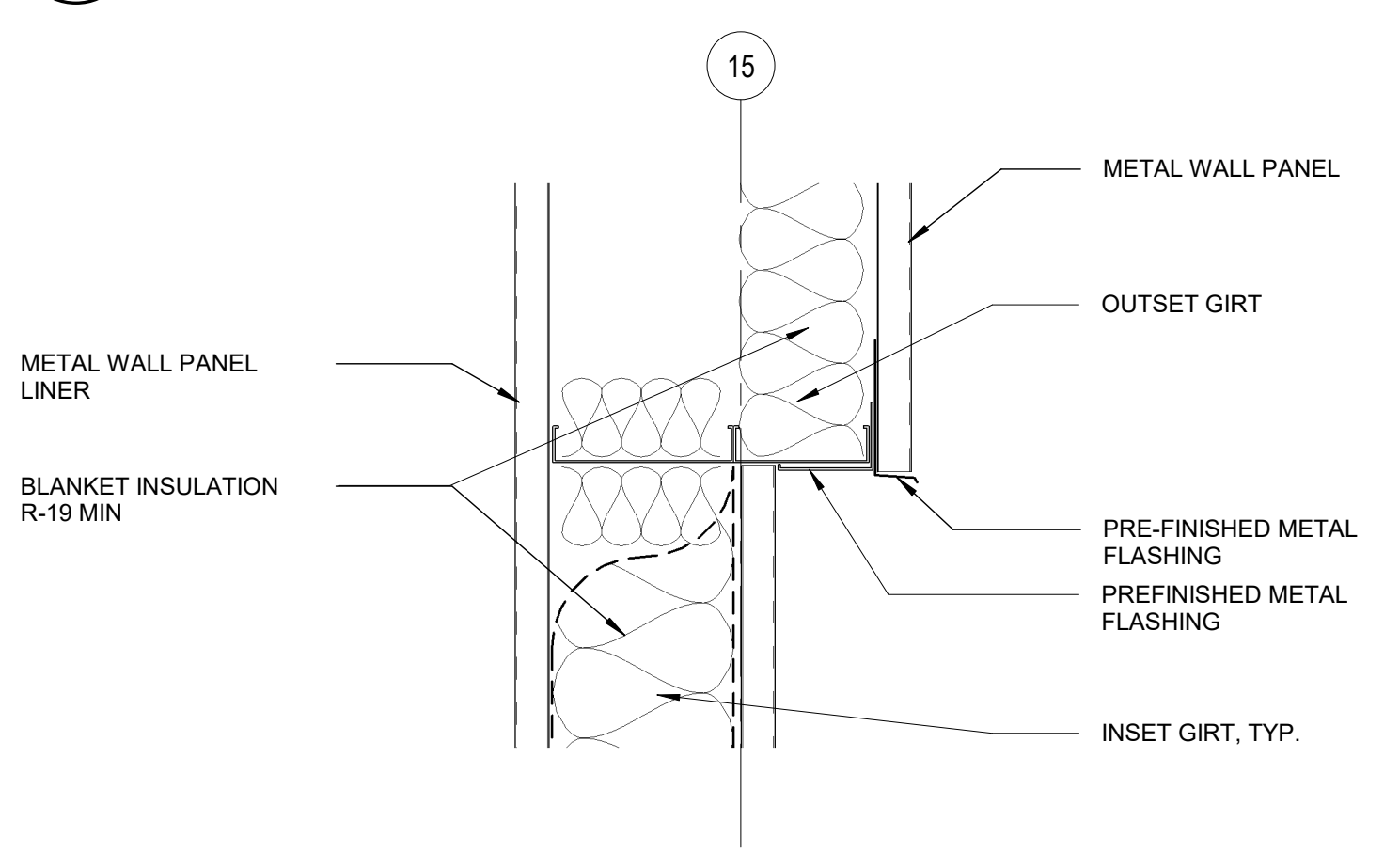

**A3** SOUTH WALL AT BUMPOUT  
1 1/2" = 1'-0"

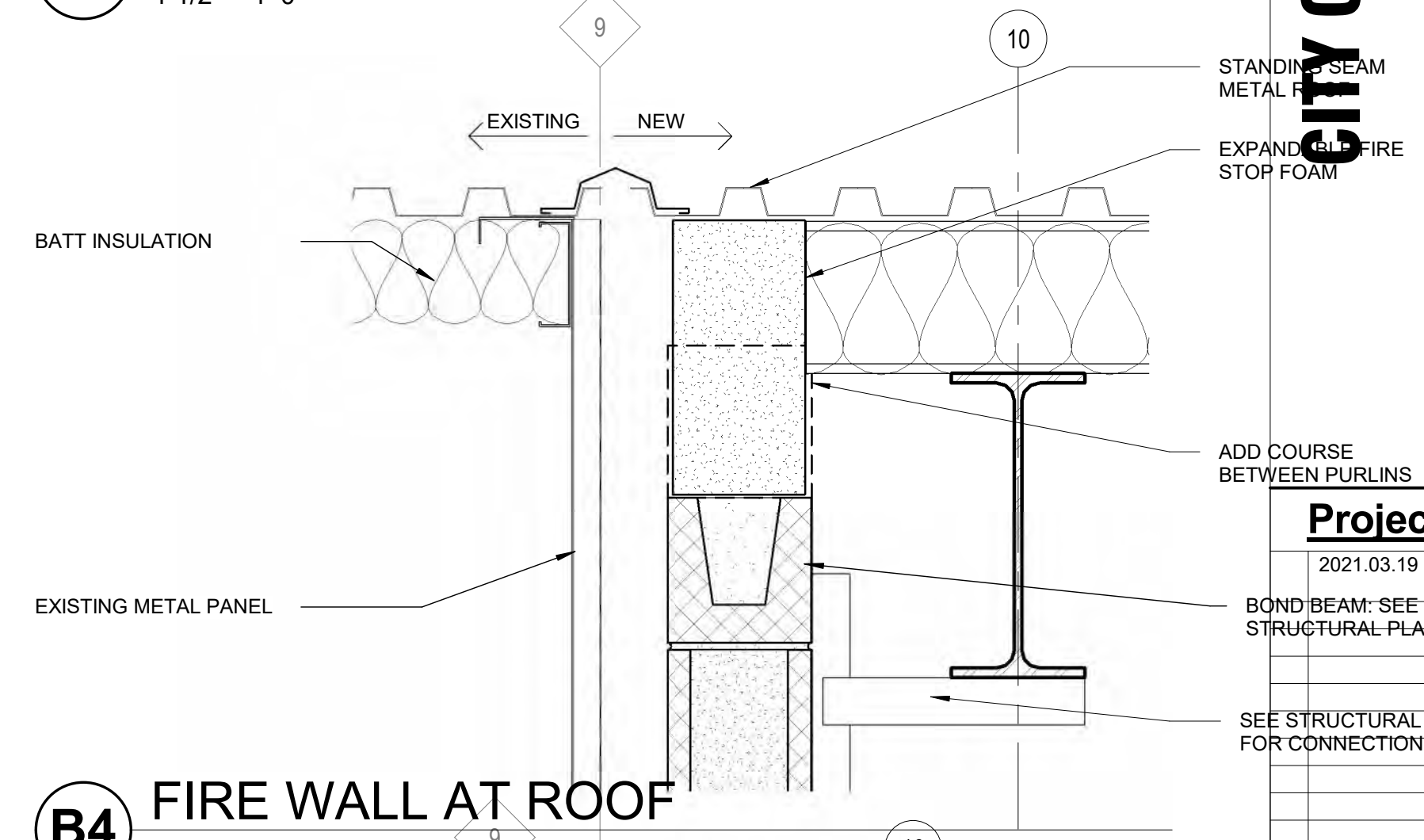

**B4** FIRE WALL AT ROOF  
1 1/2" = 1'-0"

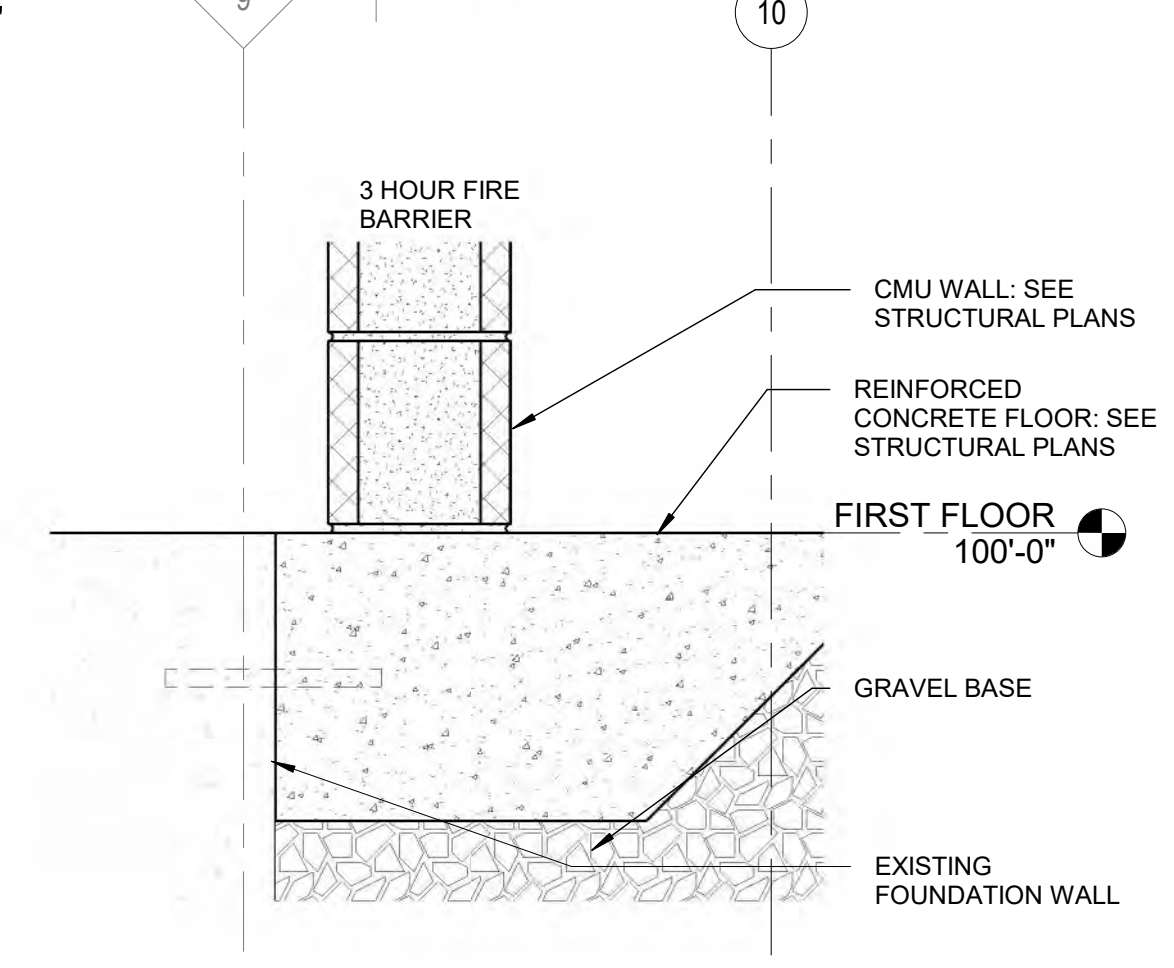

**A4** FIRE WALL AT FOUNDATION  
1 1/2" = 1'-0"

**CITY OF EVANSVILLE**  
BUILDING ADDITION  
15 OLD HWY 92  
EVANSVILLE, WI

Project Status	
2021.03.19	FOR CONSTRUCTION

PROJ. #: 20119-01

© SKETCHWORKS  
ARCHITECTURE 2020

**SECTION  
DETAILS**

**A502**

**FOR CONSTRUCTION**

**DOOR SCHEDULE**

MARK	NOMINAL DOOR SIZE (W x H)	TYPE	DOOR PANEL			GLAZING	FRAME			DOOR HARDWARE	WALL FIRE RATING	REMARKS
			MATERIAL	FINISH			TYPE	MATERIAL	FINISH			
101A	16'-0" x 14'-0"	2	BY MANUF	BY MANUF	YES	BY MANUF	BY MANUF	BY MANUF	O-50	-	-	
101B	3'-0" x 7'-0"	1	INSULATED METAL	PAINT	NO	A	INSULATED METAL	PAINT	L-3,H-20,C-30,M-60,M-61,M-62,M-63	-	-	PAINT DOOR AND FRAME, WHITE TO MATCH EXISTING DOORS ON EXTERIOR, GREY ON INTERIOR FACE
101C	3'-0" x 7'-0"	1	HOLLOW METAL	PAINT	NO	A	HOLLOW METAL	PAINT	L-2,H-20,C-30	-	-	PAINT DOOR AND FRAME, GREY
102	16'-0" x 14'-0"	2	BY MANUF	BY MANUF	YES	BY MANUF	BY MANUF	BY MANUF	O-50	-	-	
103	16'-0" x 14'-0"	2	BY MANUF	BY MANUF	YES	BY MANUF	BY MANUF	BY MANUF	O-50	-	-	
104	16'-0" x 14'-0"	2	BY MANUF	BY MANUF	YES	BY MANUF	BY MANUF	BY MANUF	O-50	-	-	
105	3'-0" x 7'-0"	1	HOLLOW METAL	PAINT	NO	A	HOLLOW METAL	PAINT	L-1,H-20,S-40	-	-	PAINT DOOR AND FRAME, GREY
106	3'-0" x 7'-0"	1	HOLLOW METAL	PAINT	NO	A	HOLLOW METAL	PAINT	L-1,H-20,S-40	-	-	PAINT DOOR AND FRAME, GREY
107	3'-0" x 7'-0"	1	INSULATED METAL	PAINT	NO	A	INSULATED METAL	PAINT	L-3,H-20,C-30,M-60,M-61,M-62,M-63	-	-	PAINT DOOR AND FRAME, WHITE TO MATCH EXISTING DOORS ON EXTERIOR, GREY ON INTERIOR FACE
108	3'-0" x 7'-0"	1	HOLLOW METAL	PAINT	NO	A	HOLLOW METAL	PAINT	L-2,H-20,C-30	3 HOUR WALL	-	FIRE RATED DOOR, PAINT DOOR AND FRAME, GREY

FIRST FLOOR: 11

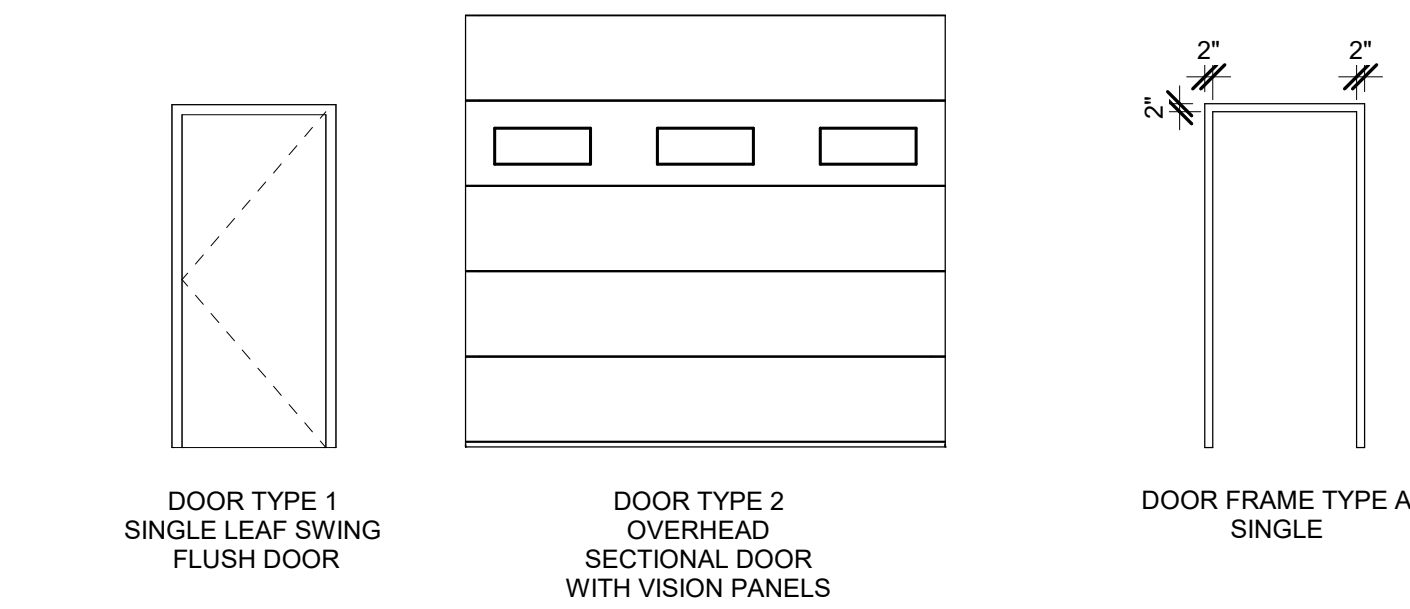

**DOOR ELEVATIONS**  
1/4" = 1'-0"

**WINDOW SCHEDULE**

MARK	NOMINAL WINDOW SIZE (W x H)	SILL HEIGHT	DESCRIPTION	MANUFACTURER	MODEL	REMARKS
A	5'-0 1/2" x 4'-0 1/2"	12'-0" AFF	ALUMINUM HORIZONTAL SLIDEWINDOW	WOJAN	M-85	1" INSULATED GLASS, BAKED ENAMEL FINISH, INSECT SCREEN

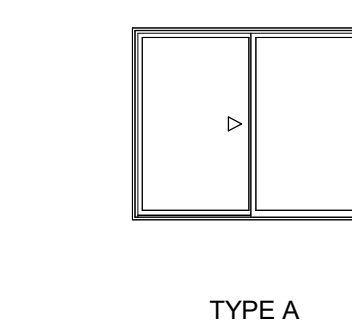

**WINDOW ELEVATIONS**  
1/4" = 1'-0"

**DOOR SCHEDULE LEGEND**

ABBREVIATION	TERM
ALUM	ALUMINUM
ETR	EXISTING TO REMAIN
HC WD	HOLLOW CORE WOOD
HM	HOLLOW METAL
INS MTL	INSULATED METAL
MANF	MANUFACTURER
PT	PAINT
SC WD	SOLID CORE WOOD
SST	STAINLESS STEEL
ST	STAIN

**DOOR HARDWARE SCHEDULE**

NO.	QTY	HARDWARE
LOCKSSETS		
L-1	1	RESTROOM PRIVACY LOCK SET
L-2	1	PASSAGE LOCK SET
L-3	1	KEYED LOCK SET
HINGES		
H-20	3	1 1/2" PAIR HINGES, STANDARD WEIGHT
CLOSERS		
C-30	1	CLOSER
STOPS		
S-40	1	WALL STOP
OPERATORS		
O-50	1	POWER OPERATOR
MISCELLANEOUS		
M-60	1	ALUMINUM THRESHOLD
M-61	1	SWEEP
M-62	1	WEATHERSTRIPPING
M-63	1	LATCH GUARD

**DOOR GENERAL NOTES:**

- A. VERIFY DOOR SIZES FROM DOOR SCHEDULE. VERIFY ALL ROUGH OPENINGS WITH RESPECTIVE MANUFACTURERS.
- B. PROVIDE SAFETY GLAZING PER CODE IN ALL DOORS AND FRAMES.
- C. PROVIDE ACCESSIBLE HARDWARE AND THRESHOLDS AT ALL NEW DOORS. REFER TO SECTION 1010 IN 2015 IBC FOR CODE REQUIREMENTS.
- D. REINFORCE ALL DOORS FOR HARDWARE WITH OWNER LOCATION AND REQUIREMENTS OF SPECIAL SECURITY DEVICES.
- E. REFER TO SHEET A001 FOR DOOR CLEARANCE REQUIREMENTS.
- F. HARDWARE SCHEDULE IS FOR BASIS OF DESIGN ONLY. SUBJECT TO CHANGE. ANY CHANGES TO THE HARDWARE SCHEDULE OR HARDWARE SELECTION MUST BE SUBMITTED TO THE ARCHITECT FOR APPROVAL.
- G. DOOR HARDWARE SCHEDULE QUANTITIES ARE PER DOOR AND DO NOT REPRESENT THE QUANTITY REQUIRED FOR ENTIRE PROJECT.

**WINDOW GENERAL NOTES:**

- A. VERIFY WINDOW SIZES FROM WINDOW SCHEDULE. VERIFY ALL ROUGH OPENINGS WITH RESPECTIVE MANUFACTURERS.



**CITY OF EVANSVILLE**  
BUILDING ADDITION  
15 OLD HWY 92  
EVANSVILLE, WI

**Project Status**

DATE	STATUS
2021.03.19	FOR CONSTRUCTION

PROJ. #: 20119-01

© SKETCHWORKS ARCHITECTURE 2021

**DOOR AND WINDOW SCHEDULES**

**A601**

D

C

B

A

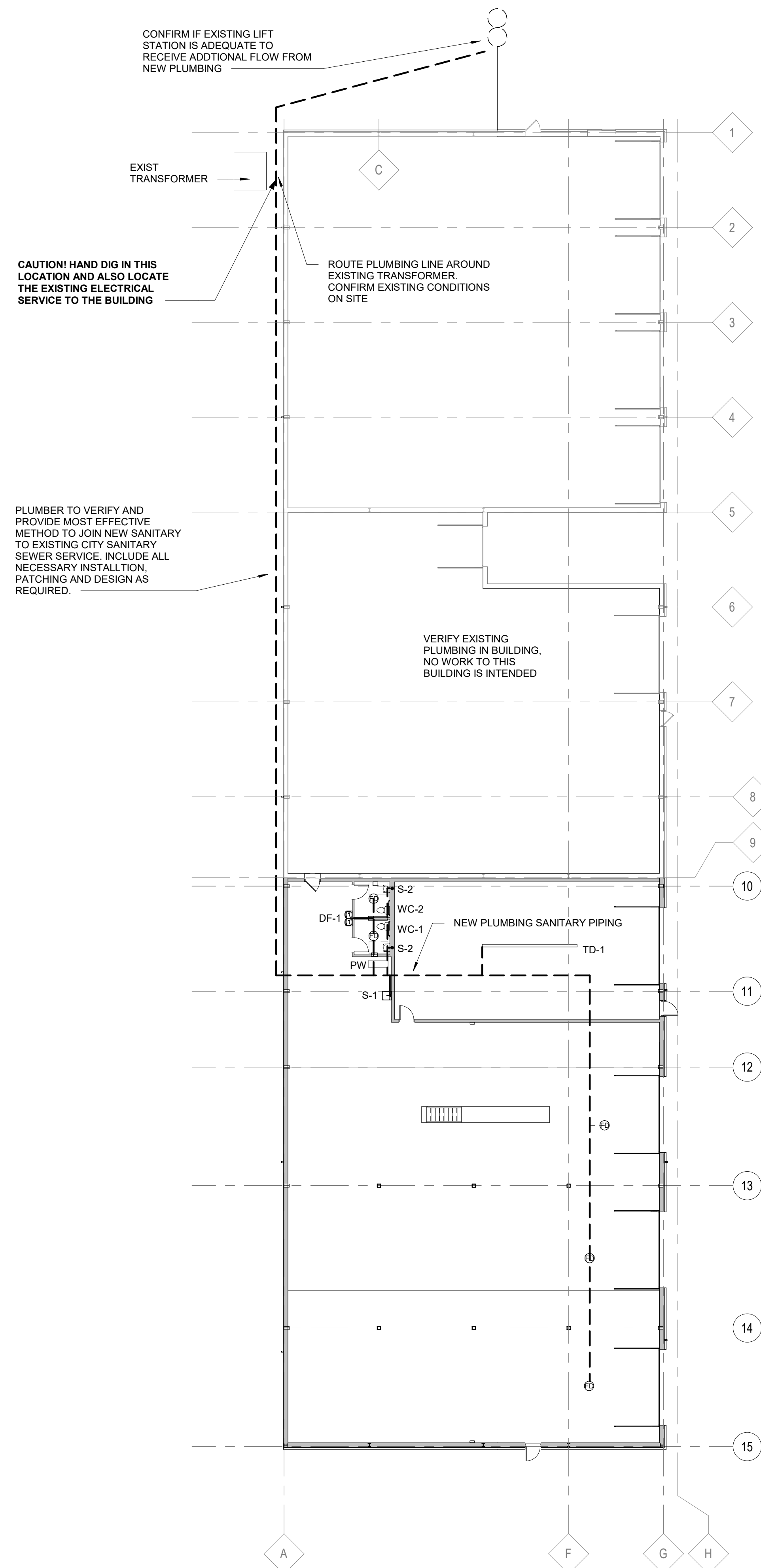

NOTE: PLUMBING SHOWN FOR GENERAL LAYOUT AND CONCEPT- FINAL DESIGN TO BE BY PLUMBING CONTRACTOR.

ALL PLUMBING SUPPLY AND SANITARY SHALL BE DESIGNED, ENGINEERED AND INSTALLED BY DESIGN-BUILD PLUMBING CONTRACTOR IN ACCORDANCE WITH STATE REGULATIONS AND CITY PREFERENCES. COORDINATE DESIGN WITH ARCHITECT AND OWNER.

S-1 = PVC SERVICE SINK, 24"X24"X18" D & FAUCET  
 S-2 = PORCELAIN WALL-HUNG SINK & FAUCET SEAT, FLOOR MOUNTED  
 WC-1 = ADA COMPLAINT PORCELAIN TOILET, TANK & SEAT, FLOOR MOUNTED  
 DF-1 = DUAL HEIGHT DRINKING FOUNTAION PREFORMED FOR ADEQUATE TRUCK LOADING  
 TD-1 = TRENCH DRAIN, HEAVY-DUTY, STAINLESS STEEL  
 FD-1 = FLOOR DRAIN, HEAVY-DUTY GRATE  
 PW = PRESSURE WASH EQUIPMENT, SEE FLOOR PLAN A102 FOR ADDITIONAL NOTES (AND ALTERNATE BID #1)

DESIGN BUILD PLUMBING CONTRACTOR SHALL PROPOSE A MEDIUM-RANGE QUALITY SUITABLE FOR CITY NEEDS AND FACILITY TYPE.

**A3** FIRST FLOOR-PLUMBING PLAN  
1/16" = 1'-0"

**CITY OF EVANSVILLE**  
**BUILDING ADDITION**  
15 OLD HWY 92  
EVANSVILLE, WI

**Project Status**

2021.03.19	FOR CONSTRUCTION

PROJ. #: 20119-01

© SKETCHWORKS ARCHITECTURE 2021

**PLUMBING LINE PLAN**

**P101**

**FOR CONSTRUCTION**

Bidding Documents and  
Technical Specifications

**CITY OF EVANSVILLE**  
**2021 MAINTENANCE BUILDING EXPANSION**

15 Old Hwy 92  
Evansville, Wisconsin 53536



**SKETCHWORKS ARCHITECTURE, LLC**  
7780 Elmwood Avenue, Middleton, WI 53562  
608-836-7570  
[www.sketchworksarch.com](http://www.sketchworksarch.com)



Division	Section Title	Revision Date	Pages
<b>SPECIFICATIONS GROUP</b>			
<i>General Requirements Subgroup</i>			
<b>DIVISION 01 - GENERAL REQUIREMENTS</b>			
01 10 00	SUMMARY	March 19, 2021	4
01 23 00	ALTERNATES	March 19, 2021	2
01 25 00	SUBSTITUTION PROCEDURES	March 19, 2021	4
01 29 00	PAYMENT PROCEDURES	March 19, 2021	4
01 31 00	PROJECT MANAGEMENT AND COORDINATION	March 19, 2021	6
01 33 00	SUBMITTAL PROCEDURES	March 19, 2021	7
01 74 19	CONSTRUCTION WASTE MANAGEMENT AND DISPOSAL	March 19, 2021	4
01 10 00	SUMMARY	March 19, 2021	5
A101-2017	DRAFT CONTRACT: AIA STANDARD FORM OF AGREEMENT BETWEEN OWNER AND CONTRACTOR	Sample Only	8
A201-2017	GENERAL CONDITIONS	March 19, 2021	40
<b>DIVISION 02 - EXISTING CONDITIONS</b>			
02 41 19	SELECTIVE DEMOLITION	March 19, 2021	4
<b>DIVISION 03 - CONCRETE</b>			
03 10 00	CONCRETE FORMING AND ACCESSORIES	March 19, 2021	6
03 20 00	CONCRETE REINFORCING	March 19, 2021	5
03 30 00	CAST-IN-PLACE CONCRETE	March 19, 2021	12
<b>DIVISION 04 - MASONRY</b>			
04 20 00	UNIT MASONRY	March 19, 2021	10
<b>DIVISION 05 - METALS</b>			
05 40 00	COLD-FORMED METAL FRAMING	March 19, 2021	6
05 50 00	METAL FABRICATIONS	March 19, 2021	3
05 51 19	METAL GRATING STAIRS	March 19, 2021	8
05 53 16	PLANK GRATINGS	March 19, 2021	4
<b>DIVISION 06 - WOOD, PLASTICS, AND COMPOSITES</b>			
06 10 00	ROUGH CARPENTRY	March 19, 2021	6
06 64 00	PLASTIC PANELING	March 19, 2021	2
<b>DIVISION 07 - THERMAL AND MOISTURE PROTECTION</b>			
07 21 00	THERMAL INSULATION	March 19, 2021	3

City of Evansville, WI  
Maintenance Garage Expansion

March 19, 2021  
For Construction

**DIVISION 08 - OPENINGS**

08 11 13	HOLLOW METAL DOORS AND FRAMES	March 19, 2021	6
08 36 13	SECTIONAL DOORS	March 19, 2021	5
08 51 13	ALUMINUM WINDOWS	March 19, 2021	4
08 71 00	DOOR HARDWARE	March 19, 2021	6

**DIVISION 09 - FINISHES**

09 29 00	GYPSUM BOARD	March 19, 2021	4
09 65 13	RESILIENT BASE AND ACCESSORIES	March 19, 2021	3
09 91 23	INTERIOR PAINTING	March 19, 2021	3

**DIVISION 10 - SPECIALTIES**

10 28 00	TOILET, BATH, AND LAUNDRY ACCESSORIES	March 19, 2021	4
10 44 16	FIRE EXTINGUISHERS	March 19, 2021	2

**DIVISION 13 - SPECIAL CONSTRUCTION**

13 34 19	METAL BUILDING SYSTEMS	March 19, 2021	14
----------	------------------------	----------------	----

**DIVISION 22 - PLUMBING**

22 14 23	STORM DRAINAGE PIPING SPECIALTIES	March 19, 2021	2
22 42 13.13	COMMERCIAL WATER CLOSETS	March 19, 2021	4
22 42 16.13	COMMERCIAL LAVATORIES	March 19, 2021	4
22 42 16.16	COMMERCIAL SINKS	March 19, 2021	4
22 47 13	DRINKING FOUNTAINS	March 19, 2021	4

**DIVISION 31 - EARTHWORK**

31 05 13	SOILS FOR EARTHWORK	March 19, 2021	8
31 22 13	ROUGH GRADING	March 19, 2021	7
31 25 00	EROSION AND SEDIMENTATION CONTROLS	March 19, 2021	9

**DIVISION 32 - EXTERIOR IMPROVEMENTS**

32 12 16	ASPHALT PAVING	March 19, 2021	9
32 13 13	CONCRETE PAVING	March 19, 2021	8
32 16 23	SIDEWALKS	March 19, 2021	9
32 91 19	LANDSCAPE GRADING	March 19, 2021	6

END OF TABLE OF CONTENTS

## INSTRUCTIONS TO BIDDERS

Article 1 - Defined Terms	1
Article 2 - Copies of Bidding Documents	1
Article 3 - Qualifications of Bidders	2
Article 4 - Bid Submittal Documents	2
Article 5 - Existing Site Conditions	2
Article 6 - General Bidder Responsibilities and Representations	2
Article 7 - Pre-Bid Conference	3
Article 8 - Interpretations and Addenda	3
Article 9 - Bid Security	4
Article 10 - Contract Times and Liquidated Damages	4
Article 11 – “Or Equal” and Substitute Material and Equipment Items	5
Article 12 - Subcontractors, Suppliers, and Others	5
Article 13 - Preparation of Bid	6
Article 14 - Affirmative Action	7
Article 15 - Submittal of Bid	7
Article 16 - Corrections of Errors in Bids	7
Article 17 - Opening of Bids	8
Article 18 - Bids to Remain Subject to Acceptance	8
Article 19 - Basis of Bids, Comparison of Bids and Award of Contract	8
Article 20 - Contract Security and Insurance	9
Article 21 - Signing of Agreement	9
Article 22 - Sales and Use Taxes	9
Article 23 – Contractor’s Insurance Requirements	10

### ARTICLE 1 - DEFINED TERMS

Terms used in these Instructions to Bidders will have the meanings indicated in the General Conditions and Supplementary Conditions. Additional terms used in these Instructions to Bidders have the meanings indicated below which are applicable to both the singular and plural thereof:

*Bidder* - Any individual or entity who submits a Bid directly to the Owner.

*Issuing Office* – (Architect) Sketchworks Architecture, LLC

*Successful Bidder* - The lowest responsible Bidder submitting a responsive Bid to whom the Owner makes an award.

### ARTICLE 2 - COPIES OF BIDDING DOCUMENTS

Complete sets of the Bidding Documents including drawings and specifications may be obtained from the office of the Owner. Refer to the Advertisement for Bid for mailing address and fees required.

Complete sets of Bidding Documents must be used in preparing Bids; neither the Owner nor Architect assumes any responsibility for errors or misinterpretations resulting from the use of incomplete sets of Bidding Documents.

The Owner and Architect is making copies of Bidding Documents available on the above terms do so only for the purpose of obtaining Bids for the Work and do not authorize or confer a license or grant for any other use.

#### ARTICLE 4 - BID SUBMITTAL DOCUMENTS

Documents to be submitted to the Owner by the Bid Deadline shall include the Bid Proposal, the addendum acknowledgement and signature pages; Affidavit of Organization and Authority; and a Bid Bond or Bid Security.

#### ARTICLE 5 - EXISTING SITE CONDITIONS

Contractor is responsible for visiting the site and area of Work prior to submitting a bid. Existing drawings or documentation of the existing facilities is very limited. Copies of any drawings will be made available to any Bidder on request. Those reports and drawings may not be part of the Contract Documents, but the "Technical Data" contained therein upon which Bidder is entitled to rely as provided in Article 5 of the General Conditions has thus been identified and established. Each Bidder is responsible for any interpretation or conclusion Bidder draws from any "Technical Data" or any other data, interpretations, opinions or information contained in such report or indicated in such drawings. The Article 5 of the General Conditions establishes responsibilities and procedures to be followed regarding reasonable interpretation of the information, and uncovering unidentified site conditions.

#### ARTICLE 6 - GENERAL BIDDER RESPONSIBILITIES AND REPRESENTATIONS

It is the responsibility of each Bidder before submitting a Bid to:

- Examine and carefully study the Bidding Documents, including the Plans and any Addenda and the other related data identified in the Bidding Documents;
- Visit the Site and become familiar with and satisfy Bidder as to the general, local, and Site conditions that may affect cost, progress, and performance of the Work;
- Become familiar with all federal, state, and local laws and regulations that may affect cost, progress, or performance of the Work;
- Carefully study all reports as described above in the Existing Site Conditions section and identified in the Supplementary Conditions as containing reliable "technical data";
- Undertake additional testing or studies at the Bidder's expense that the Bidder considers necessary to adequately prepare a Bid for the Work, and agree at the time of submitting a Bid that no further examinations, investigations, explorations, tests, studies, or data are necessary for the determination of its Bid for performance of the Work at the price(s) bid and within the times required, and in accordance with the other terms and conditions of the Bidding Documents;
- Consider the information known to Bidder; information commonly known to contractors doing business in the locality of the Site; information and observations obtained from visits to the Site; the Bidding Documents; and the



Site-related reports and drawings identified in the Bidding Documents, with respect to the effect of such information, observations, and documents on (1) the cost, progress, and performance of the Work; (2) the means, methods, techniques, sequences, and procedures of construction to be employed by Bidder;

- Become aware of the general nature of the work to be performed by Owner and others at the Site that relates to the Work as indicated in the Bidding Documents;
- Promptly provide Architect written notice of all conflicts, errors, ambiguities, or discrepancies that the Bidder discovers in the Bidding Documents and confirm that the written resolution thereof by Architect is acceptable to the Bidder; and
- Determine that the Bidding Documents are generally sufficient to indicate and convey understanding of all terms and conditions for the performance of the Work.

The submission of a Bid will constitute an incontrovertible representation that the Bidder has complied with every requirement of this Instructions to Bidders including those listed above, that without exception the Bid is premised upon performing and furnishing the Work required by the Bidding Documents.

In addition, by submitting a Bid the Bidder agrees to the following:

- The Owner shall be the sole authority for determining conformance of substitute bid items with the Contract Documents.
- The Owner shall not be required to justify decisions made on substitute bid items.
- Substitutions or modifications for material, equipment, Manufacturers, Suppliers and Subcontractors will not be considered after receipt of Bids unless approved in writing by the Owner

#### ARTICLE 7- PRE-BID CONFERENCE

A pre-bid conference will be held at the designated date and time per the Advertisement to Bid, at the project site. Representatives of the Architect and the Owner will be present to discuss the project. Bidders are (encouraged) to attend and participate in the conference. Architect will transmit to all prospective Bidders of Record such addenda as it considers necessary in response to questions arising at the conference. Oral statements may not be relied upon and will not be binding or legally effective.

#### ARTICLE 8 - INTERPRETATIONS AND ADDENDA

All questions about the meaning or intent of the Bidding Documents are to be submitted to Architect in writing. Interpretations or clarifications considered necessary by Architect in response to such questions will be issued by Addenda mailed, e-mailed, faxed or delivered to all parties recorded by Architect as having received the Bidding Documents. Questions received less than five working days prior to the date for opening of Bids may not be answered. Only questions answered by Addenda will be binding. Oral and other interpretations or clarifications will be without legal effect.

Addenda may be issued to clarify, correct, supplement or change the Bidding Documents as deemed advisable by Owner or Architect.

All Addenda so issued shall become part of the Contract Documents and Technical Specifications and must be acknowledged by the Bidder on the Bid Proposal Form. Failure of any bidder to receive any such addendum shall not relieve that bidder from any obligation under his bid as submitted. Failure to acknowledge addenda shall, at the Owner's discretion, be grounds for rejection of the bid.

#### ARTICLE 9 - BID SECURITY

Each Bid must be accompanied by Bid security made payable to the Owner in an amount of 5% of the Bidder's maximum Bid Price (determined by adding the base bid and any alternates and supplemental bid items), or in an amount otherwise required in the Advertisement for Bid, in the form of a certified check, bank money order or a Bid Bond on the form enclosed in the Bidding Documents or on a form issued by a surety meeting the requirements of paragraph 6.01 of the General Conditions. Bonds shall be executed by the Bidder and a surety corporation licensed to transact business in Wisconsin. Attorneys-in-fact who signs bid bonds must file with each bond a certified and current copy of their power of attorney.

The Bid security of the apparent Successful Bidder will be retained until such time that the Bidder has executed the Contract Documents, furnished the required contract security and met the other conditions of the Notice of Award, whereupon the Bid security will be returned.

If the Successful Bidder fails to execute and deliver the Contract Documents and furnish the required contract security within 10 days after the Notice of Award, the Owner may consider Bidder to be in default, annul the Notice of Award and the Bid security of that Bidder will be forfeited. Such forfeiture shall be Owner's exclusive remedy if Bidder defaults.

The Bid security of other Bidders whom the Owner believes to have a reasonable chance of receiving the Contract Award may be retained by the Owner until the earlier of seven days after the Effective Date of the Agreement or one day after the end of the acceptance period established in Article 18 of this Instructions to Bidders, whereupon Bid security furnished by such Bidders will be returned.

Bid security of other Bidders whom Owner believes do not have a reasonable chance of receiving the award will be returned within seven days after the Owner makes such determination.

#### ARTICLE 10 - CONTRACT TIMES AND LIQUIDATED DAMAGES

The number of days within which, or the dates by which, the Work (or milestones, thereof) is to be (a) Substantially Completed and (b) also completed and ready for final payment are set forth in the Bid Proposal or Section 01 10 00-Summary of Work of the Specifications and will be included in the final Contract Agreement. In addition, the Bid Proposal and/or Division 1 sections establish the liquidated damage amounts that can be assessed against the Contractor for failure to comply with the Contract times.

#### ARTICLE 11 – “OR EQUAL” AND SUBSTITUTE MATERIAL AND EQUIPMENT ITEMS

The Contract, if awarded, will be on the basis of materials and equipment specified or described in the Bidding Documents, Plans and Specifications. “Or-equal” or substitute materials and equipment as defined in the General Conditions, may be approved by the Architect, identified by Addendum and considered in the contract award. The materials and equipment described in the Bidding Documents establish a standard of required type, function, quality and life cycle cost to be met by any proposed substitute or “or-equal” item.

Requests for Architect’s clarification of materials and equipment the Architect considers “or-equal” must be received by the Architect at least 5 working days prior to the date for receipt of Bids.

Requests for “or equal” items not listed in the Bidding Documents, Plans or Specifications and requests for substitute items of material or equipment will be considered by Architect if a written request for approval has been submitted by a prospective Bidder (not an equipment or material supplier except in procurement bids) and has been received by Architect at least 15 days prior to the date for receipt of Bids. Each such request shall conform to the requirements of paragraphs 7.04 or 7.05 of the General Conditions, as applicable. The burden of proof of the merit of such proposed items is upon the Bidder. Architect’s decision of approval or disapproval of a proposed item will be final. If Architect approves any such a proposed “or equal” or substitute item, such approval will be set forth in an Addendum issued to all prospective Bidders. Bidders shall not rely upon approvals made in any other manner.

#### ARTICLE 12 - SUBCONTRACTORS, SUPPLIERS, AND OTHERS

Major Subcontractors and suppliers shall be listed on the appropriate Schedule of the Bid Proposal. If Subcontractors or Suppliers are not specifically listed on the Schedule, a complete listing of these must be submitted to the Owner from the Successful Bidder within five days after the Bid opening. Failure to do so may constitute grounds for rejection of the bid. When so requested by the Owner, a Bidder shall submit an experience statement with pertinent information regarding similar projects and other evidence of qualification for Subcontractors, Suppliers, individuals, or similar entities. Before the Notice of Award is given, if the Owner and Architect, after due investigation, have reasonable objection to any proposed Subcontractor, Supplier, individual, or entity, the Owner may require the apparent successful Bidder to submit a substitute. In this case the Bidder’s Base Bid price will be increased (or decreased) by the difference in cost occasioned by such substitution, and Owner may consider such price adjustment in evaluating Bids and making the contract award.

If the apparent Successful Bidder declines to make any such substitution, the Owner may award the Contract to the next lowest Bidder that proposes to use acceptable Subcontractors, Suppliers, individuals, or entities. Declining to make requested substitutions will not constitute grounds for forfeiture of the Bid security of any Bidder. Any Subcontractor, Supplier, individual, or entity so listed and against which Owner or Architect makes no written objection prior to the giving of the Notice of Award will be deemed acceptable to Owner subject to revocation of such acceptance after the effective date of the Agreement as provided in paragraph 6.06 of the General Conditions.

The Contractor shall not be required to employ any Subcontractor, Supplier, individual, or entity against whom the Contractor has reasonable objection.

#### ARTICLE 13 - PREPARATION OF BID

The Bid Form is included with the Bidding Documents.

All blanks on the Bid Form shall be completed in ink and the Bid Form signed in ink. Erasures or alterations shall be initialed in ink by the person signing the Bid Form. A Bid price shall be indicated for each section, base bid item, alternate bid item or supplemental bid item for which a blank space has been provided. In the case of optional alternates the words "No Bid," "No Change," or "Not Applicable" may be entered as appropriate. Unless noted as "required" in the Bid Proposal form, all alternates shall be considered as optional.

A Bid by a corporation shall be executed in the corporate name by the president or a vice-president or other corporate officer accompanied by evidence of authority to sign. The corporate seal shall be affixed and attested by the secretary or an assistant secretary. The corporate address and state of incorporation shall be shown.

A Bid by a partnership shall be executed in the partnership name and signed by a partner (whose title must appear under the signature), accompanied by evidence of authority to sign. The official address of the partnership shall be shown.

A Bid by a limited liability company shall be executed in the name of the firm by a member and accompanied by evidence of authority to sign. The state of formation of the firm and the official address of the firm shall be shown.

A Bid by an individual shall show the Bidder's name and official address.

A Bid by a joint venture shall be executed by each joint venturer in the manner indicated on the Bid Form. The official address of the joint venture shall be shown.

All names shall be printed in ink below the signatures.

The Bid shall contain an acknowledgment of receipt of all Addenda, the numbers of which shall be filled in on the Bid Form.

Postal and e-mail addresses and telephone number for communications regarding the Bid shall be shown.

The Bid shall contain evidence of Bidder's authority and qualification to do business in the state where the Project is located, or Bidder shall covenant in writing to obtain such authority and qualification prior to award of the Contract and attach such covenant to the Bid. Bidder's state contractor license number, if any, shall also be shown on the Bid Form.



#### ARTICLE 14 - AFFIRMATIVE ACTION

Bidders shall agree not to discriminate against any employee or applicant for employment because of age, race, religion, color, handicap, sex, physical condition, and developmental disability as defined by Wisconsin State Statutes. This provision shall include but not be limited to the following: employment, upgrading, demotion or transfer, recruitment or recruitment advertising, layoff or termination, rate of pay or other forms of compensation, and selection for training including apprenticeship. The Contractor further agrees to take affirmative action to ensure equal employment opportunities for persons with disabilities. The Contractor agrees to post in conspicuous places, available to employees and applicants for employment, notices setting forth the provisions of the non-discrimination clause.

#### ARTICLE 15 - SUBMITTAL OF BID

Provide (1) one hard copy and (1) one electronic copy of the Bid.

A Bid shall be received no later than the date and time prescribed and at the place indicated in the Advertisement for Bids and shall be enclosed in an opaque sealed envelope or package plainly marked with the Project title (and, if applicable, the designated portion of the Project for which the Bid is submitted), the name and address of Bidder, and shall be accompanied by the Bid security and other required documents. If a Bid is sent by mail or other delivery system, the sealed envelope containing the Bid shall be enclosed in a separate envelope plainly marked on the outside with the notation "BID ENCLOSED." A mailed Bid shall be addressed to the OWNER at the address set forth on the first page of the Bid Proposal.

#### ARTICLE 16 - CORRECTIONS OF ERRORS IN BIDS

Section 66.0901 (5) of Wisconsin Statutes applies to modification, withdrawal and corrections of errors in bids, stating as follows:

"(5) CORRECTIONS OF ERRORS IN BIDS. If a person submits a bid or proposal for the performance of public work under any public contract to be let by a municipality and the bidder claims a mistake, omission or error has been made in preparing the bid, the bidder shall, before the bids are opened, make known the fact that an error, omission or mistake has been made. If the bidder makes this fact known, the bid shall be returned to the bidder unopened and the bidder may not bid upon the public contract unless it is readvertised and relet upon the readvertisement.

If a bidder makes an error, omission or mistake and discovers it after the bids are opened, the bidder shall immediately and without delay give written notice and make known the fact of the mistake, omission or error which has been committed and submit to the municipality clear and satisfactory evidence of the mistake, omission or error and that it was not caused by any careless act or omission on the bidder's part in the exercise of ordinary care in examining the plans or specifications and in conforming with the provisions of this section. If the discovery and notice of a mistake, omission or error causes a forfeiture, the bidder may not recover the moneys or certified check forfeited as liquidated damages unless it is proven before a court of competent jurisdiction in an action brought for

the recovery of the amount forfeited, that in making the mistake, error or omission the bidder was free from carelessness, negligence or inexcusable neglect.”

#### ARTICLE 17 - OPENING OF BIDS

Bids will be opened at the time and place indicated in the advertisement and, unless obviously non-responsive, read aloud publicly. Unsigned bids, incomplete bids and bids not accompanied by bid bonds may be considered unresponsive for purposes of reading the bids aloud. In the case of unsigned bids, if a legally authorized representative of the Bidder is present, the authorized representative will be allowed to sign the bid before it is read aloud publicly. The Owner will then decide whether such a bid will be accepted. An abstract of the amounts of the Bids, including alternates, if any, will be made available to Bidders after the opening of Bids.

#### ARTICLE 18 - BIDS TO REMAIN SUBJECT TO ACCEPTANCE

All Bids will remain subject to acceptance for the period of time stated in the Advertisement for Bid, in the Bid Form or as outlined above in the description of the Bid Security. The Owner may in its sole discretion release any Bid and return the Bid security prior to the end of this period. If no such period of time is stated in the Advertisement for Bids or in the Bid Form, the bids will remain subject to acceptance for a period of ninety (90) calendar days from the Bid Deadline.

#### ARTICLE 19 - BASIS OF BIDS, COMPARISON OF BIDS AND AWARD OF CONTRACT

Bidders shall submit a Bid on a lump sum basis for the Base Bid and include a separate price for each supplemental bid item and for each required alternate described in the Bidding Documents as provided in the Bid Form. In the evaluation of Bids to determine a low bidder, the Base Bid plus alternates in any number and in any order or combination and the total of the supplemental bid items may be selected for award unless otherwise identified in the Bid Proposal form.

The Owner reserves the right to reject any or all Bids, including without limitation, nonconforming, non-responsive, unbalanced, or conditional Bids. Bids may be rejected for failure to comply with any requirements of this section, for alterations of the form, additions to or qualifications on the form, erasures, use of lead pencil to fill out the form, mathematical errors, failure to sign the form, failure to submit bid security, or irregularities of any kind. The Owner further reserves the right to reject the Bid of any Bidder whom it finds, after reasonable inquiry and evaluation, to be non-responsible. The Owner also reserves the right to waive all informalities not involving price, time, or changes in the Work and to negotiate contract terms with the Successful Bidder. The Owner also reserves the right to waive any minor informality and to determine what constitutes a minor informality.

More than one Bid for the same Work from an individual or entity under the same or different names will not be considered. Reasonable grounds for believing that any Bidder has an interest in more than one Bid for the Work may be cause for disqualification of that Bidder and the rejection of all Bids in which that Bidder has an interest.

In evaluating Bids, the Owner will consider whether or not the Bids comply with the

prescribed requirements, as may be requested in the Bid Form or prior to the Notice of Award.

In evaluating Bidders, the Owner will consider the qualifications of Bidders and may consider the qualifications and experience of Subcontractors, Suppliers, and other individuals or entities proposed for those portions of the Work for which the identity of Subcontractors, Suppliers, and other individuals or entities must be submitted as provided in the Supplementary Conditions.

The Owner may conduct such investigations as deemed necessary to establish the responsibility, qualifications, and financial ability of Bidders, proposed Subcontractors, Suppliers, individuals, or entities to perform the Work in accordance with the Contract Documents.

If the Contract is to be awarded, Owner will award the Contract to the Bidder whose Bid is in the best interests of the Project.

#### ARTICLE 20 - CONTRACT SECURITY AND INSURANCE

Article 6 of the General Conditions, as may be modified by the Supplementary Conditions, sets forth The Owner's requirements as to performance and payment Bonds and insurance. When the Successful Bidder delivers the executed Agreement to the Owner, it must be accompanied by the required contract security and Certificate of Insurance.

#### ARTICLE 21 - SIGNING AGREEMENT

When OWNER gives a Notice of Award to the Successful Bidder, it shall be accompanied by the required number of unsigned counterparts of the Agreement with the other Contract Documents that are identified in the Agreement as attached thereto. Within ten (10) days thereafter, the Successful Bidder shall sign and deliver the required number of counterparts of the Agreement and attached documents to the Owner. Within ten (10) days thereafter, the Owner shall deliver one fully signed counterpart to Successful Bidder with a complete set of the Drawings with appropriate identification, unless such complete set of drawings has already been delivered.

#### ARTICLE 22 - SALES AND USE TAXES

OWNER is exempt from Wisconsin State sales and use taxes on materials and equipment to be incorporated in the Work; said taxes shall not be included in the Bid.

ARTICLE 23 – CONTRACTOR’S INSURANCE REQUIREMENTS

The limits of liability for the insurance required by Paragraph 6.03 of the General Conditions shall provide coverage for not less than the following amounts or greater where required by Laws and Regulations:

1. Worker’s Compensation Insurance and related coverages. Prime Contractors are required to provide Workmen’s Compensation Insurance for the duration of this project meeting statutory requirements. Prime Contractors shall require subcontractors to provide Workmen’s Compensation Insurance for all subcontractor employees working on this project, unless covered by Prime Contractor’s policy.

Employer’s Liability            \$500,000

Projects in Wisconsin constructed by out-of-state contractors or subcontractors must be so endorsed on the policy and noted on the certificate.

2. Contractor’s General Liability Insurance. This policy shall be provided by and in the name of each Prime Contractor and shall include completed operations and product liability coverages, and independent Contractor’s Contingent coverage.

Minimum limits:

\$1,000,000            Each Person  
\$1,000,000            Each Occurrence  
\$2,000,000            General Aggregate

Delete exclusions for X-C-U (Explosion, Collapse, and Underground) perils and any exclusion with respect to property under the care, custody and control of the Contractor.

3. Automobile Liability Insurance. This policy shall be provided by and in the name of each Prime Contractor. Coverage shall include all owned, non-owned, and hired vehicles. Prime Contractors shall require similar coverages by subcontractors.

Minimum Limits:

Bodily Injury	\$1,000,000	Each Person
	\$1,000,000	Each Occurrence
Property Damage	\$1,000,000	Each Occurrence
Combined Single Limit	\$1,000,000	

4. Umbrella Coverage. This policy shall be provided by and in the name of each Prime Contractor. Coverage shall include all the categories above and shall be for the following minimum limits: \$5,000,000, each occurrence and general aggregate.

5. Contractor’s Pollution Liability:

Each Occurrence	N/A
General Aggregate	N/A

Contractor is not required to provide Contractor’s Pollution Liability insurance under this Contract



6.	Contractor's Professional Liability:	
	Each Claim	N/A
	Annual Aggregate	N/A

For purposes of these requirements additional insureds shall be:

the OWNER: City of Evansville, Wisconsin  
the ARCHITECT: Sketchworks Architecture, Middleton, WI

## **BID PROPOSAL FORM**

**PROJECT: 2021 MAINTENANCE BUILDING EXPANSION**

**OWNER:** City of Evansville  
31 S. Madison Street  
Evansville, WI 53536

**PRE-BID WALKTHROUGH:** April 8, 2021 at 9:00 a.m., local time

**BID DEADLINE:** April 21, 2021 at 1:00 p.m., local time  
**PUBLIC BID OPENING**

### **Part 1 – General**

#### **1.1 Bid Proposal Preparation**

- A. The undersigned Bidder proposes and agrees, if this Bid is accepted, to enter into an Agreement with Owner on the form included in the Bidding Documents to perform all Work as specified or indicated in the Bidding Documents for the prices and within the times indicated in this Bid and in accordance with the other terms and conditions of the Bidding Documents. This shall include provision of a Performance Bond and a Payment Bond each in the amount of 100% of the Contract amount.
- B. Reference the Instruction to Bidders before completing this Bid Proposal form. The Affidavit of Organization and Authority, Bid Bond, and the Disclosure of Ownership documents must be submitted along with this Bid Proposal form in order to comply with the bidding requirements.
- C. All information requested must be provided within the following sections of this Bid Proposal:
  - 1. Part 2 – Base Bid Summary
  - 2. Part 3 – Acknowledgements and Representations
  - 3. Part 4 – Bid Signature Page
- D. The Total Base Bid Price shall include all work required for construction of the project that may reasonably be inferred from the plan sheets and specifications as being required to produce the intended result whether or not specifically identified by any particular proposal schedule item.

#### **1.2 Specified Manufacturers and Equipment**

- A. The contract documents are prepared using a basis of design of certain materials and equipment from specific manufacturers. The material and equipment may be identified by manufacturer's name.
- B. Naming the manufacturer is intended to establish a minimum standard of the type, function, and

quality required and is intended to establish a common basis for all bids to ensure that the Owner receives the full benefit of any savings in cost that may be associated with substitute material and equipment from an alternate manufacturer.

- C. Bidders who believe other substitute material and equipment manufacturers or suppliers can meet or exceed the specified performance and technical requirements for any equipment item are encouraged to provide an optional alternate. It will be the sole responsibility of the Contractor to ensure that substitute equipment and/or Suppliers meet the design specifications.

### **1.3 Contract Award**

- A. The overall Bid Cost to be used to determine the apparent low Bidder shall be determined based on the accumulated total of the following:
- Total Bid Cost
  - Any one item cost, multiple item cost, or all cost additions or deductions for Optional Alternates
  - Any one item cost or all cost additions or deductions for Alternates listed
- B. The Owner reserves the right to use or eliminate any, or all of the Alternates or Optional Alternates provided, and any, or all of the Additive/Deductive bid items in determining the low bidder. In no event will the overall Bid Cost be adjusted if equipment proposed by the Contractor is rejected during submittal review or during equipment testing.
- C. Award of the contract will be made on the basis of the evaluation of all Bid Proposal forms submitted. Award will be made to the Bidder with the lowest overall Bid Cost if the bid is determined to be comprehensive and the Bidder has been determined to be qualified.
- D. Each Bidder's base bid price will include the use of the Subcontractors listed in the Bid Proposal.

### **1.4 Disadvantaged Business Enterprises (MBE/WBE/SBRA)**

- A. Refer to Regulatory Requirements for the minority business enterprises (MBE), women-owned business enterprises (WBE) and small businesses in rural areas (SBRA) requirements for the project. Documentation of advertisement and solicitation must be submitted with the Bid Proposal. Remaining documentation shall be submitted within three (3) working days after the bids are received.

### **1.5 Project Time Schedule and Liquidated Damages**

- A. Bidder agrees that the Work will be substantially completed and ready for final payment in accordance with the General Conditions on or before the dates or within the number of calendar days set forth below and indicated in the Agreement. (also see ALTERNATE No. 3)

**Substantial Completion      December 31, 2021**

**Final Completion**

**January 31, 2022**

- B. Furthermore, the Bidder agrees that time is of the essence in performing this Contract and that the Owner will suffer financial loss if the Work (and each individual milestone) is not completed within the specified time frames given above. The Bidder acknowledges the delays, expense, and difficulties involved in proving in a legal or arbitration proceeding the actual loss suffered by the Owner if the Work is not completed on time. Accordingly, instead of requiring any such proof, the Bidder agrees that as liquidated damages to compensate the Owner for additional engineering, legal and administrative costs associated with delay (and not as a penalty or as compensation for other losses), the successful bidding Contractor shall pay Owner the following sums for each day that expires after the times specified for completion as set forth above which will be used in the contract documents:

\$500 per calendar day for substantial completion

\$500 per calendar day for final completion



**Part 2 – Bid Summary**

**2.1 General Requirements**

- A. The Bidder shall specify a Base Bid Price for all work required per the Contract Documents. The Base Bid Price shall include furnishing and installing all materials, labor, equipment, and necessary work to complete the project as depicted on the drawings and in the specifications inclusive of all Base Bid equipment items that are listed in Schedule A and all other equipment and materials required by the Plan Sheets and Specifications.
- B. Allowances, if any, shall be totaled and added to line B below.
- C. Alternate Bid #1, per Specification section 01 23 00, shall be listed on line C below.
- D. Alternate Bid #2, per Specification section 01 23 00, shall be listed on line D below.
- E. Alternate Bid #3, per Specification section 01 23 00, shall be listed on line E below.

**2.2 Bid Summary**

A. Base Bid Price (lump sum)	\$ _____	
B. Allowance Items (if any)	\$ _____	
C. Alternate #1, deduct pressure wash equipment	\$ _____	
D. Alternate #2, deduct bridge crane	\$ _____	
E. Alternate #3, schedule flexibility	\$ _____	
<b>Total Bid Cost</b>	<b>\$</b> <table border="1" style="display: inline-table; vertical-align: middle;"><tr><td style="width: 150px; height: 20px;"></td></tr></table>	

### Part 3 – Acknowledgements and Representations

#### 3.1 Acknowledgements

- A. By signing this Bid Proposal the Bidder acknowledges that failure to bid all items will be grounds for rejection of the bid and that the Owner has the right to reject any and all bids, including bids which in the opinion of the Owner, are excessive or are not sufficient to properly carry out the work.
- B. Furthermore the Bidder acknowledges the right of the Owner to reject the bid of bidders who have previously failed to properly perform or complete on time contracts of similar nature.
- C. Bidder accepts all of the terms and conditions of the Advertisement to Bid and Instructions to Bidders, including without limitation those dealing with the disposition of Bid security. The Bid will remain subject to acceptance for 90 days after the Bid opening, or for such longer period of time that Bidder may agree to in writing upon request of Owner.

#### 3.2 Bidder Representations

- A. In submitting this Bid, the Bidder represents as set forth in the Agreement that the acknowledgements and requirements described below have been agreed to.
- B. The Bidder has examined and carefully studied the Bidding Documents, the other related data identified in the Bidding Documents, and has visited the Site and become familiar with and is satisfied as to the general, local and Site conditions that may affect cost, progress, and performance of the Work.
- C. Bidder has examined the following Addenda, receipt of all of which is hereby acknowledged.

<u>Addendum No.</u>	<u>Addendum Date</u>
_____	_____
_____	_____
_____	_____
_____	_____

- D. Bidder is familiar with and is satisfied as to all federal, state and local Laws and regulations that may affect cost, progress and performance of the Work.
- E. Bidder has carefully studied (1) reports of explorations and tests of subsurface conditions at or contiguous to the site and all drawings of physical conditions relating to existing surface or subsurface structures at the site (except underground facilities) that have been identified in the Supplementary Conditions as containing reliable “technical data”, and (2) reports and drawings of Hazardous Environmental Conditions, if any, at the site that have been identified in the Supplementary Conditions as containing reliable “technical data”.
- F. Bidder has considered the information known to Bidder; information commonly known to

contractors doing business in the locality of the site; information and observations obtained from visits to the site; the Bidding Documents, and the site-related reports and drawings identified in the Bidding Documents, with respect to the effect of such information, observations and documents on (1) the cost, progress, and performance of the Work; (2) the means, methods, techniques, sequences and procedures of construction to be employed by the Bidder, including applying the specific means, methods, techniques, sequences and procedures of construction expressly required by the Bidding Document; and (3) Bidder's safety precautions and programs.

- G. Bidder does not consider that any further examinations, investigations, explorations, tests, studies, or data are necessary for the determination of this Bid for performance of the Work at the price(s) bid and within the times and in accordance with the other terms and conditions of the Bidding Documents.
- H. Bidder is aware of the general nature of work to be performed by OWNER and others at the Site that relates to the Work as indicated in the Bidding Documents.
- I. Bidder has correlated the information known to Bidder, information and observations obtained from visits to the Site, reports and drawings identified in the Bidding Documents, and all additional examinations, investigations, explorations, tests, studies, and data with the Bidding Documents.
- J. Bidder has given Owner written notice of all conflicts, errors, ambiguities, or discrepancies that Bidder has discovered in the Bidding Documents, and the written resolution thereof by Owner is acceptable to Bidder.
- K. The Bidding Documents are generally sufficient to indicate and convey understanding of all terms and conditions for the performance of the Work for which this Bid is submitted.
- L. Bidder further represents that this Bid is genuine and not made in the interest of or on behalf of any undisclosed individual or entity and is not submitted in conformity with any agreement or rules of any group, association, organization or corporation; Bidder has not directly or indirectly induced or solicited any other Bidder to submit a false or sham Bid; Bidder has not solicited or induced any individual or entity to refrain from bidding; and Bidder has not engaged in corrupt, fraudulent, collusive or coercive practices in competing for the contract.

**Part 4 – Bid Signature Page**

The Bid Proposal and this Bid Signature Form is hereby submitted on and by:

\_\_\_\_\_  
(Date)

\_\_\_\_\_  
(Company Name)

\_\_\_\_\_  
(Printed Name of Authorized Signatory)

\_\_\_\_\_  
(Signature) (SEAL)

\_\_\_\_\_  
(Title)

\_\_\_\_\_  
(Witness or Notary Public Signature)

Contact Information:

\_\_\_\_\_  
(Business Address)

\_\_\_\_\_  
(Phone Number)

\_\_\_\_\_  
(Fax Number)

Notes:

1. For partnerships, signature must be made by one of the general partners.
2. For joint venture projects, representative signature from each joint venture company must be provided. Attach appropriate signature pages as necessary.
3. The corporate or company seal shall be affixed over the signature for incorporated businesses.

## SECTION 01 10 00 - SUMMARY

### PART 1 - GENERAL

#### 1.1 SUMMARY

A. Section Includes:

1. Project information.
2. Work covered by Contract Documents.
3. Phased construction.
4. Work under Owner's separate contracts.
5. Owner-furnished/Contractor-installed (OFI) products.
6. Contractor's use of site and premises.
7. Coordination with occupants.
8. Work restrictions.
9. Specification and Drawing conventions.

#### 1.2 PROJECT INFORMATION

A. Project Identification: Maintenance Garage Expansion

1. Project Location:

15 Old Hwy 92, Evansville, WI 53562

B. Owner:

City of Evansville, WI  
31 S Madison St., P.O. Box 529, Evansville, WI 53536

1. Owner's Representative:

Chad Renly, Municipal Services Director  
535 S. Madison St., Evansville, WI 53536  
[chad.renly@ci.evansville.wi.gov](mailto:chad.renly@ci.evansville.wi.gov)  
608-490-1313

C. Architect:

Sketchworks Architecture, LLC  
7780 Elmwood Ave., suite 208, Middleton, WI 53562

1. Architect's Representative:

Nick Badura  
[nbadura@sketchworksarch.com](mailto:nbadura@sketchworksarch.com)  
608-836-7570



### 1.3 WORK COVERED BY CONTRACT DOCUMENTS

A. The Work of Project is defined by the Contract Documents and consists of the following:

1. Expansion of existing maintenance garage, of approximately 9,600 square feet, including new maintenance bays, wash bay, associated site work, and other Work indicated in the Contract Documents.
  - a. All Mechanical, Electrical, and Plumbing work shall be performed in a design-build delivery, with the respective sub-contractor being responsible for final design, engineering, and preparation of construction and permitting documents.
    - 1) HVAC shall consist of electric or gas radiant overhead heat across all bays. There will not be any cooling in this building. Provide sufficient make-up air per code. Wash bay shall have sufficient make-up air, ventilation and air movement to mitigate moisture per reasonable and comparable industry standards. Bathroom shall have supplemental heat source if needed, and exhaust ventilation. Mechanical contractor shall verify existing system and supplement or extend service as necessary to provide code-compliant environment for intended use and occupants.
    - 2) Electrical shall provide sufficient power and distribution to Owners anticipate maintenance bay equipment, mechanical equipment, wash equipment and convenience outlets. Lighting shall consist of high-bay LED fixtures to complement existing. Bathroom shall have sufficient ceiling mounted and wall mounted sconces. Wash bay fixtures to be sealed weather-tight. Provide allowance for maintenance bay task lighting, two location per each bay. Electrical contractor shall field verify existing service and distribution to ensure adequate power and circuiting exists. Supplement all as needed.
    - 3) Plumbing fixtures are specified and/or called out in plan as a basis of design. A concept sanitary piping plan is shown for illustration only, but is not the mandated method. Plumbing contractor shall field verify all existing conditions and develop the reasonable solution to provide for fixtures and equipment intended.

B. Type of Contract:

1. Project will be constructed under a single prime contract.

### 1.4 PHASED CONSTRUCTION

A. The Work shall be conducted in a single phase

1. Commencement of Construction:
  - a. Notice to Proceed: Work shall commence no later than 10 business days after the Notice to Proceed.
  - b. Approximate construction start is May 24, 2021.

2. Substantial Completion:
  - a. Work shall be completed no later than December 31, 2021. (ALSO SEE ALTERNATE NO. 3)
3. Final Completion:
  - a. Work shall be finally complete, including any punchlist items, no later than January 31, 2022.

#### 1.5 WORK UNDER SEPARATE CONTRACTS

- A. General: Cooperate fully with separate contractors so work on those contracts may be carried out smoothly, without interfering with or delaying Work under this Contract or other contracts. Coordinate the Work of this Contract with work performed under separate contracts.
  1. No concurrent contracts at the project site are identified at this time, Owner will inform and coordinate with contractor of any future concurrent contracts.

#### 1.6 OWNER-FURNISHED/CONTRACTOR-INSTALLED (OFICI) PRODUCTS

- A. Owner's Responsibilities: Owner will furnish products indicated and perform the following, as applicable:
  1. Provide to Contractor Owner-reviewed Product Data, Shop Drawings, and Samples.
  2. Provide for delivery of Owner-furnished products to Project site.
  3. Upon delivery, inspect, with Contractor present, delivered items.
    - a. If Owner-furnished products are damaged, defective, or missing, arrange for replacement.
  4. Obtain manufacturer's inspections, service, and warranties.
  5. Inform Contractor of earliest available delivery date for Owner-furnished products.
- B. Contractor's Responsibilities: The Work includes the following, as applicable:
  1. Designate delivery dates of Owner-furnished products in Contractor's construction schedule, utilizing Owner-furnished earliest available delivery dates.
  2. Review Owner-reviewed Product Data, Shop Drawings, and Samples, noting discrepancies and other issues in providing for Owner-furnished products in the Work.
  3. Receive, unload, handle, store, protect, and install Owner-furnished products.
  4. Make building services connections for Owner-furnished products.
  5. Protect Owner-furnished products from damage during storage, handling, and installation and prior to Substantial Completion.
  6. Repair or replace Owner-furnished products damaged following receipt.

C. Owner-Furnished/Contractor-Installed (OFICI) Products:

1. None.

1.7 CONTRACTOR'S USE OF SITE AND PREMISES

A. Limits on Use of Site: Limit use of Project site to areas within the Contract limits indicated. Do not disturb portions of Project site beyond areas in which the Work is indicated.

1. Limits on Use of Site: Confine construction operations to the immediate driveway location, project site, and vacant staging area immediately to the south and southeast of the project site.
2. Driveways, Walkways, and Entrances: Keep driveways loading areas and entrances serving premises clear and available to Owner, Owner's employees, and emergency vehicles at all times. Do not use these areas for parking or for storage of materials.

B. Condition of Existing Building: Maintain portions of existing building affected by construction operations in a weathertight condition throughout construction period. Repair damage caused by construction operations.

C. Condition of Existing Grounds: Maintain portions of existing grounds, landscaping, and hardscaping affected by construction operations throughout construction period. Repair damage caused by construction operations.

1.8 COORDINATION WITH OCCUPANTS

A. Full Owner Occupancy: Owner will occupy site and existing adjacent building(s) during entire construction period. Cooperate with Owner during construction operations to minimize conflicts and facilitate Owner usage. Perform the Work so as not to interfere with Owner's day-to-day operations. Maintain existing exits unless otherwise indicated.

1.9 WORK RESTRICTIONS

A. Comply with restrictions on construction operations.

1. Comply with limitations on use of public streets, work on public streets, rights of way, and other requirements of authorities having jurisdiction.

B. On-Site Work Hours: Limit work in the existing building to normal business working hours of 7:00 a.m. to 6:00 p.m., Monday through Friday, unless otherwise indicated.

C. Existing Utility Interruptions: Do not interrupt utilities serving facilities occupied by Owner or others unless permitted under the following conditions and then only after providing temporary utility services according to requirements indicated:

1. Notify Owner not less than two days in advance of proposed utility interruptions.
2. Obtain Owner's written permission before proceeding with utility interruptions.

- D. Noise, Vibration, Dust, and Odors: Coordinate operations that may result in high levels of noise and vibration, dust, odors, or other disruption to Owner occupancy with Owner.
- E. Smoking and Controlled Substance Restrictions: Use of tobacco products, alcoholic beverages, and other controlled substances on Owner's property is not permitted.

PART 2 - PRODUCTS (Not Used)

PART 3 - EXECUTION (Not Used)

END OF SECTION 01 10 00

## SECTION 01 23 00 - ALTERNATES

### PART 1 - GENERAL

#### 1.1 SUMMARY

- A. Section includes administrative and procedural requirements for alternates.

#### 1.2 DEFINITIONS

- A. Alternate: An amount proposed by bidders and stated on the Bid Form for certain work defined in the bidding requirements that may be added to or deducted from the base bid amount if the Owner decides to accept a corresponding change either in the amount of construction to be completed or in the products, materials, equipment, systems, or installation methods described in the Contract Documents.
  - 1. Alternates described in this Section are part of the Work only if enumerated in the Agreement.
  - 2. The cost or credit for each alternate is the net addition to or deduction from the Contract Sum to incorporate alternates into the Work. No other adjustments are made to the Contract Sum.

#### 1.3 PROCEDURES

- A. Coordination: Revise or adjust affected adjacent work as necessary to completely integrate work of the alternate into Project.
  - 1. Include as part of each alternate, miscellaneous devices, accessory objects, and similar items incidental to or required for a complete installation whether or not indicated as part of alternate.
- B. Execute accepted alternates under the same conditions as other work of the Contract.
- C. Schedule: A schedule of alternates is included at the end of this Section. Specification Sections referenced in schedule contain requirements for materials necessary to achieve the work described under each alternate.

### PART 2 - PRODUCTS (Not Used)



## PART 3 - EXECUTION

### 3.1 SCHEDULE OF ALTERNATES

#### A. Alternate No. 1: Deduct Pressure-Washer.

1. Base Bid: Provide hot-water pressure wash equipment and installation as indicated on Drawings. Work to include all necessary plumbing and electrical service for fully operational wash system.
2. Alternate: Deduct the hot-water pressure wash equipment from the scope of work to be purchased and installed by owner at a later date. Space shall remain prepared for future installation, including adequate plumbing and electrical to the location of primary equipment.

#### B. Alternate No. 2: Deduct Bridge Crane.

1. Base Bid: Provide bridge crane, rails, power and installation as indicated on Drawings. Work to include all necessary structure and electrical service for fully operational crane system.
2. Alternate: Deduct bridge crane equipment and structural steel rails from the scope of work to be purchased and installed by owner at a later date. Structure shall remain prepared for future installation, including adequate structural support of columns and foundations.

#### C. Alternate No. 3: Extend Project Schedule.

1. Base Bid: Completion of project according to Schedule and Phased Construction described in Specification 01 10 00, "Project Summary".
2. Alternate: Allow project schedule flexibility to extend the date of Substantial Completion by up to six months.

END OF SECTION 01 23 00

## SECTION 01 25 00 - SUBSTITUTION PROCEDURES

### PART 1 - GENERAL

#### 1.1 SUMMARY

- A. Section includes administrative and procedural requirements for substitutions.

#### 1.2 DEFINITIONS

- A. Substitutions: Changes in products, materials, equipment, and methods of construction from those required by the Contract Documents and proposed by Contractor.
  - 1. Substitutions for Cause: Changes proposed by Contractor that are required due to changed Project conditions, such as unavailability of product, regulatory changes, or unavailability of required warranty terms.
  - 2. Substitutions for Convenience: Changes proposed by Contractor or Owner that are not required in order to meet other Project requirements but may offer advantage to Contractor or Owner.

#### 1.3 ACTION SUBMITTALS

- A. Substitution Requests: Submit electronically each request for consideration. Identify product or fabrication or installation method to be replaced. Include Specification Section number and title and Drawing numbers and titles.
  - 1. Documentation: Show compliance with requirements for substitutions and the following, as applicable:
    - a. Statement indicating why specified product or fabrication or installation method cannot be provided, if applicable.
    - b. Coordination of information, including a list of changes or revisions needed to other parts of the Work and to construction performed by Owner and separate contractors that will be necessary to accommodate proposed substitution.
    - c. Detailed comparison of significant qualities of proposed substitutions with those of the Work specified. Include annotated copy of applicable Specification Section. Significant qualities may include attributes, such as performance, weight, size, durability, visual effect, sustainable design characteristics, warranties, and specific features and requirements indicated. Indicate deviations, if any, from the Work specified.
    - d. Product Data, including drawings and descriptions of products and fabrication and installation procedures.
    - e. Samples, where applicable or requested. (provide 3 samples if requested)
    - f. Certificates and qualification data, where applicable or requested.

- g. List of similar installations for completed projects, with project names and addresses as well as names and addresses of architects and owners.
  - h. Material test reports from a qualified testing agency, indicating and interpreting test results for compliance with requirements indicated.
  - i. Research reports evidencing compliance with building code in effect for Project, from ICC-ES.
  - j. Detailed comparison of Contractor's construction schedule using proposed substitutions with products specified for the Work, including effect on the overall Contract Time. If specified product or method of construction cannot be provided within the Contract Time, include letter from manufacturer, on manufacturer's letterhead, stating date of receipt of purchase order, lack of availability, or delays in delivery.
  - k. Cost information, including a proposal of change, if any, in the Contract Sum.
  - l. Contractor's certification that proposed substitution complies with requirements in the Contract Documents, except as indicated in substitution request, is compatible with related materials and is appropriate for applications indicated.
  - m. Contractor's waiver of rights to additional payment or time that may subsequently become necessary because of failure of proposed substitution to produce indicated results.
2. Architect's Action: If necessary, Architect will request additional information or documentation for evaluation within seven days of receipt of a request for substitution. Architect will notify Contractor of acceptance or rejection of proposed substitution within 10 days of receipt of request, or 5 days of receipt of additional information or documentation, whichever is later.
- a. Forms of Acceptance: Change Order, Construction Change Directive, or Architect's Supplemental Instructions for minor changes in the Work.
  - b. Use product specified if Architect does not issue a decision on use of a proposed substitution within time allocated.

#### 1.4 QUALITY ASSURANCE

- A. Compatibility of Substitutions: Investigate and document compatibility of proposed substitution with related products and materials. Engage a qualified testing agency to perform compatibility tests recommended by manufacturers.

#### 1.5 PROCEDURES

- A. Coordination: Revise or adjust affected work as necessary to integrate work of the approved substitutions.

## 1.6 SUBSTITUTIONS

- A. Substitutions for Cause: Submit requests for substitution immediately on discovery of need for change, but not later than 15 days prior to time required for preparation and review of related submittals.
1. Conditions: Architect will consider Contractor's request for substitution when the following conditions are satisfied. If the following conditions are not satisfied, Architect will return requests without action, except to record noncompliance with these requirements:
    - a. Requested substitution is consistent with the Contract Documents and will produce indicated results.
    - b. Substitution request is fully documented and properly submitted.
    - c. Requested substitution will not adversely affect Contractor's construction schedule.
    - d. Requested substitution has received necessary approvals of authorities having jurisdiction.
    - e. Requested substitution is compatible with other portions of the Work.
    - f. Requested substitution has been coordinated with other portions of the Work.
    - g. Requested substitution provides specified warranty.
    - h. If requested substitution involves more than one contractor, requested substitution has been coordinated with other portions of the Work, is uniform and consistent, is compatible with other products, and is acceptable to all contractors involved.
- B. Substitutions for Convenience: Architect will consider requests for substitution if received within 30 days after **the Notice to Proceed**. Requests received after that time may be considered or rejected at discretion of Architect.
1. Conditions: Architect will consider Contractor's request for substitution when the following conditions are satisfied. If the following conditions are not satisfied, Architect will return requests without action, except to record noncompliance with these requirements:
    - a. Requested substitution offers Owner a substantial advantage in cost, time, energy conservation, or other considerations, after deducting additional responsibilities Owner must assume. Owner's additional responsibilities may include compensation to Architect for redesign and evaluation services, increased cost of other construction by Owner, and similar considerations.
    - b. Requested substitution does not require extensive revisions to the Contract Documents.
    - c. Requested substitution is consistent with the Contract Documents and will produce indicated results.
    - d. Substitution request is fully documented and properly submitted.
    - e. Requested substitution will not adversely affect Contractor's construction schedule.
    - f. Requested substitution has received necessary approvals of authorities having jurisdiction.

- g. Requested substitution is compatible with other portions of the Work.
- h. Requested substitution has been coordinated with other portions of the Work.
- i. Requested substitution provides specified warranty.
- j. If requested substitution involves more than one contractor, requested substitution has been coordinated with other portions of the Work, is uniform and consistent, is compatible with other products, and is acceptable to all contractors involved.

PART 2 - PRODUCTS (Not Used)

PART 3 - EXECUTION (Not Used)

END OF SECTION 01 25 00



## SECTION 01 29 00 - PAYMENT PROCEDURES

### PART 1 - GENERAL

#### 1.1 SUMMARY

- A. Section includes administrative and procedural requirements necessary to prepare and process Applications for Payment.

#### 1.2 SCHEDULE OF VALUES

- A. Coordination: Coordinate preparation of the schedule of values with preparation of Contractor's construction schedule.
  - 1. Coordinate line items in the schedule of values with items required to be indicated as separate activities in Contractor's construction schedule.
  - 2. Submit the schedule of values to Owner and Architect at earliest possible date, but no later than seven days before the date scheduled for submittal of initial Applications for Payment.
- B. Format and Content: Use Project Manual table of contents as a guide to establish line items for the schedule of values. Provide at least one line item for each Specification Section.
  - 1. Arrange schedule of values consistent with format of AIA Document G703.
  - 2. Provide a breakdown of the Contract Sum in enough detail to facilitate continued evaluation of Applications for Payment and progress reports. Provide multiple line items for principal subcontract amounts in excess of five percent of the Contract Sum.
  - 3. Provide a separate line item in the schedule of values for each part of the Work where Applications for Payment may include materials or equipment purchased or fabricated and stored, but not yet installed.
    - a. Differentiate between items stored on-site and items stored off-site.
  - 4. Allowances: Provide a separate line item in the schedule of values for each allowance. Show line-item value of unit-cost allowances, as a product of the unit cost, multiplied by measured quantity. Use information indicated in the Contract Documents to determine quantities.
  - 5. Overhead Costs: Include total cost and proportionate share of general overhead and profit for each line item.
  - 6. Schedule of Values Revisions: Revise the schedule of values when Change Orders or Construction Change Directives result in a change in the Contract Sum. Include at least one separate line item for each Change Order and Construction Change Directive.

### 1.3 APPLICATIONS FOR PAYMENT

- A. Each Application for Payment following the initial Application for Payment shall be consistent with previous applications and payments as certified by Architect and paid for by Owner.
- B. Payment Application Times: The date for each progress payment is indicated in the Agreement between Owner and Contractor. The period of construction work covered by each Application for Payment is the period indicated in the Agreement.
  - 1. Submit draft copy of Application for Payment **five** days prior to due date for review by Architect.
- C. Application for Payment Forms: Use AIA Document G702 and AIA Document G703 as form for Applications for Payment.
- D. Application Preparation: Complete every entry on form. Notarize and execute by a person authorized to sign legal documents on behalf of Contractor. **Architect** will return incomplete applications without action.
  - 1. Entries shall match data on the schedule of values and Contractor's construction schedule. Use updated schedules if revisions were made.
  - 2. Include amounts for work completed following previous Application for Payment, whether or not payment has been received. Include only amounts for work completed at time of Application for Payment.
  - 3. Include amounts of Change Orders and Construction Change Directives issued before last day of construction period covered by application.
- E. Transmittal: Submit three signed and notarized original copies of each Application for Payment to Architect. One copy shall include waivers of lien and similar attachments if required.
  - 1. Transmit each copy with a transmittal form listing attachments and recording appropriate information about application.
- F. Waivers of Mechanic's Lien: With each Application for Payment, submit waivers of mechanic's lien from entities lawfully entitled to file a mechanic's lien arising out of the Contract and related to the Work covered by the payment.
  - 1. Submit partial waivers on each item for amount requested in previous application, after deduction for retainage, on each item.
  - 2. When an application shows completion of an item, submit conditional final or full waivers.
  - 3. Owner reserves the right to designate which entities involved in the Work must submit waivers.
  - 4. Submit final Application for Payment with or preceded by conditional final waivers from every entity involved with performance of the Work covered by the application who is lawfully entitled to a lien.
  - 5. Waiver Forms: Submit executed waivers of lien on forms acceptable to Owner.

- G. Initial Application for Payment: Administrative actions and submittals that must precede or coincide with submittal of first Application for Payment include the following:
1. List of subcontractors.
  2. Schedule of values.
  3. Contractor's construction schedule (preliminary if not final).
  4. Products list (preliminary if not final).
  5. Sustainable design action plans, including preliminary project materials cost data.
  6. Schedule of unit prices.
  7. Submittal schedule (preliminary if not final).
  8. List of Contractor's staff assignments.
  9. List of Contractor's principal consultants.
  10. Copies of building permits.
  11. Copies of authorizations and licenses from authorities having jurisdiction for performance of the Work.
  12. Initial progress report.
  13. Report of preconstruction conference.
  14. Certificates of insurance and insurance policies.
  15. Performance and payment bonds (if applicable)
  16. Data needed to acquire Owner's insurance.
- H. Application for Payment at Substantial Completion: After Architect issues the Certificate of Substantial Completion, submit an Application for Payment showing 100 percent completion for portion of the Work claimed as substantially complete.
1. Include documentation supporting claim that the Work is substantially complete and a statement showing an accounting of changes to the Contract Sum.
  2. This application shall reflect Certificate(s) of Substantial Completion issued previously for Owner occupancy of designated portions of the Work.
- I. Final Payment Application: After completing Project closeout requirements, submit final Application for Payment with releases and supporting documentation not previously submitted and accepted, including, but not limited, to the following:
1. Evidence of completion of Project closeout requirements.
  2. Insurance certificates for products and completed operations where required and proof that taxes, fees, and similar obligations were paid.
  3. Updated final statement, accounting for final changes to the Contract Sum.
  4. AIA Document G706.
  5. AIA Document G706A.
  6. Evidence that claims have been settled.
  7. Final meter readings for utilities, a measured record of stored fuel, and similar data as of date of Substantial Completion or when Owner took possession of and assumed responsibility for corresponding elements of the Work.

PART 2 - PRODUCTS (Not Used)

PART 3 - EXECUTION (Not Used)

END OF SECTION 01 29 00

## SECTION 01 31 00 - PROJECT MANAGEMENT AND COORDINATION

### PART 1 - GENERAL

#### 1.1 SUMMARY

- A. Section includes administrative provisions for coordinating construction operations on Project including, but not limited to, the following:
  - 1. General coordination procedures.
  - 2. Coordination drawings.
  - 3. RFIs.
  - 4. Digital project management procedures.
  - 5. Project meetings.
- B. Related Requirements:

#### 1.2 INFORMATIONAL SUBMITTALS

- A. Subcontract List: Prepare a written summary identifying individuals or firms proposed for each portion of the Work, including those who are to furnish products or equipment fabricated to a special design. Include the following information in tabular form:
  - 1. Name, address, telephone number, and email address of entity performing subcontract or supplying products.
  - 2. Number and title of related Specification Section(s) covered by subcontract.
  - 3. Drawing number and detail references, as appropriate, covered by subcontract.

#### 1.3 GENERAL COORDINATION PROCEDURES

- A. Coordination: Coordinate construction operations included in different Sections of the Specifications to ensure efficient and orderly installation of each part of the Work. Coordinate construction operations included in different Sections that depend on each other for proper installation, connection, and operation.
  - 1. Schedule construction operations in sequence required to obtain the best results where installation of one part of the Work depends on installation of other components, before or after its own installation.
  - 2. Coordinate installation of different components to ensure maximum performance and accessibility for required maintenance, service, and repair.
  - 3. Make adequate provisions to accommodate items scheduled for later installation.
- B. Administrative Procedures: Coordinate scheduling and timing of required administrative procedures with other construction activities to avoid conflicts and to ensure orderly progress of the Work. Such administrative activities include, but are not limited to, the following:



1. Preparation of Contractor's construction schedule.
2. Preparation of the schedule of values.
3. Installation and removal of temporary facilities and controls.
4. Delivery and processing of submittals.
5. Progress meetings.
6. Preinstallation conferences.
7. Project closeout activities.
8. Startup and adjustment of systems.

#### 1.4 COORDINATION DRAWINGS

- A. Coordination Drawings, General: Prepare coordination drawings according to requirements in individual Sections, and additionally where installation is not completely indicated on Shop Drawings, where limited space availability necessitates coordination, or if coordination is required to facilitate integration of products and materials fabricated or installed by more than one entity.
1. Content: Project-specific information, drawn accurately to a scale large enough to indicate and resolve conflicts. Do not base coordination drawings on standard printed data. Include the following information, as applicable:
    - a. Indicate functional and spatial relationships of components of architectural, structural, civil, mechanical, and electrical systems.
    - b. Indicate dimensions shown on Drawings. Specifically note dimensions that appear to be in conflict with submitted equipment and minimum clearance requirements. Provide alternative sketches to Architect indicating proposed resolution of such conflicts. Minor dimension changes and difficult installations will not be considered changes to the Contract.
- B. Coordination Drawing Organization: Organize coordination drawings as follows:
1. Floor Plans and Reflected Ceiling Plans: Show architectural and structural elements, and mechanical, plumbing, fire-protection, fire-alarm, and electrical Work. Show locations of visible ceiling-mounted devices relative to acoustical ceiling grid. Supplement plan drawings with section drawings where required to adequately represent the Work.
  2. Mechanical Rooms: Provide coordination drawings for mechanical rooms showing plans and elevations of mechanical, plumbing, fire-protection, fire-alarm, and electrical equipment.
  3. Structural Penetrations: Indicate penetrations and openings required for all disciplines.
  4. Slab Edge and Embedded Items: Indicate slab edge locations and sizes and locations of embedded items for metal fabrications, sleeves, anchor bolts, bearing plates, angles, door floor closers, slab depressions for floor finishes, curbs and housekeeping pads, and similar items.
  5. Review: Architect will review coordination drawings to confirm that, in general, the Work is being coordinated, but not for the details of the coordination, which are Contractor's responsibility. If Architect determines that coordination drawings are not being prepared in sufficient scope or detail, or are otherwise deficient,

Architect will so inform Contractor, who shall make suitable modifications and resubmit.

#### 1.5 REQUEST FOR INFORMATION (RFI)

- A. General: Immediately on discovery of the need for additional information, clarification, or interpretation of the Contract Documents, Contractor shall prepare and submit an RFI in the form specified.
1. Architect will return without response those RFIs submitted to Architect by other entities controlled by Contractor.
  2. Coordinate and submit RFIs in a prompt manner so as to avoid delays in Contractor's work or work of subcontractors.
- B. Content of the RFI: Include a detailed, legible description of item needing information or interpretation and the following:
1. Owner name.
  2. Owner's Project number.
  3. Name of Architect.
  4. Architect's Project number.
  5. Date.
  6. Name of Contractor.
  7. RFI number, numbered sequentially.
  8. RFI subject.
  9. Specification Section number and title and related paragraphs, as appropriate.
  10. Drawing number and detail references, as appropriate.
  11. Field dimensions and conditions, as appropriate.
  12. Contractor's suggested resolution. If Contractor's suggested resolution impacts the Contract Time or the Contract Sum, Contractor shall state impact in the RFI.
  13. Contractor's signature.
  14. Attachments: Include sketches, descriptions, measurements, photos, Product Data, Shop Drawings, coordination drawings, and other information necessary to fully describe items needing interpretation.
- C. RFI Forms: AIA Document G716 or Software-generated form with substantially the same content as indicated above, acceptable to Architect.
- D. Architect's Action: Architect will review each RFI, determine action required, and respond. Allow **three** days for Architect's response for each RFI. RFIs received by Architect after 3:00 p.m. will be considered as received the following working day.
1. The following Contractor-generated RFIs will be returned without action:
    - a. Requests for approval of submittals.
    - b. Requests for approval of substitutions.
    - c. Requests for approval of Contractor's means and methods.
    - d. Requests for coordination information already indicated in the Contract Documents.
    - e. Requests for adjustments in the Contract Time or the Contract Sum.

- f. Requests for interpretation of Architect's actions on submittals.
    - g. Incomplete RFIs or inaccurately prepared RFIs.
  2. Architect's action may include a request for additional information, in which case Architect's time for response will date from time of receipt by Architect of additional information.
  3. Architect's action on RFIs that may result in a change to the Contract Time or the Contract Sum may be eligible for Contractor to submit Change Proposal according to Owner's Contract Modification Procedures.
    - a. If Contractor believes the RFI response warrants change in the Contract Time or the Contract Sum, notify Architect in writing within five days of receipt of the RFI response.
- E. RFI Log: Prepare, maintain, and submit a tabular log of RFIs organized by the RFI number.
  1. Project name.
  2. Name and address of Contractor.
  3. Name and address of Architect.
  4. RFI number including RFIs that were returned without action or withdrawn.
  5. RFI description.
  6. Date the RFI was submitted.
  7. Date Architect's response was received.
- F. On receipt of Architect's action, update the RFI log and immediately distribute the RFI response to affected parties. Review response and notify Architect within three days if Contractor disagrees with response.

## 1.6 DIGITAL PROJECT MANAGEMENT PROCEDURES

- A. Use of Architect's Digital Data Files: Digital data files of Architect's BIM model will be provided by Architect for Contractor's use during construction.
  1. Digital data files may be used by Contractor in preparing coordination drawings, Shop Drawings, and Project record Drawings.
  2. Architect makes no representations as to the accuracy or completeness of digital data files as they relate to Contract Drawings.
  3. Contractor shall execute a data licensing agreement form acceptable to Owner and Architect.
- B. PDF Document Preparation: Where PDFs are required to be submitted to Architect, prepare as follows:
  1. Assemble complete submittal package into a single indexed file incorporating submittal requirements of a single Specification Section and transmittal form with links enabling navigation to each item.
  2. Name file with submittal number or other unique identifier, including revision identifier.

3. Certifications: Where digitally submitted certificates and certifications are required, provide a digital signature with digital certificate on where indicated.

## 1.7 PROJECT MEETINGS

- A. General: **Schedule and conduct** meetings and conferences at Project site unless otherwise indicated.
- B. Preconstruction Conference: **Schedule and conduct** a preconstruction conference before starting construction, at a time convenient to Owner and Architect, but no later than **15** days after execution of the Agreement.
  1. Attendees: Authorized representatives of Owner, Architect, and their consultants; Contractor and its superintendent; major subcontractors; suppliers; and other concerned parties shall attend the conference. Participants at the conference shall be familiar with Project and authorized to conclude matters relating to the Work.
  2. Agenda: Discuss items of significance that could affect progress, including the following:
    - a. Responsibilities and personnel assignments.
    - b. Tentative construction schedule.
    - c. Phasing.
    - d. Critical work sequencing and long lead items.
    - e. Designation of key personnel and their duties.
    - f. Lines of communications.
    - g. Use of any web-based Project software.
    - h. Procedures for processing field decisions and Change Orders.
    - i. Procedures for RFIs.
    - j. Procedures for testing and inspecting.
    - k. Procedures for processing Applications for Payment.
    - l. Distribution of the Contract Documents.
    - m. Submittal procedures.
    - n. Preparation of Record Documents.
    - o. Use of the premises and existing building.
    - p. Work restrictions.
    - q. Working hours.
    - r. Owner's occupancy requirements.
    - s. Responsibility for temporary facilities and controls.
    - t. Procedures for moisture and mold control.
    - u. Procedures for disruptions and shutdowns.
    - v. Construction waste management and recycling.
    - w. Parking availability.
    - x. Office, work, and storage areas.
    - y. Equipment deliveries and priorities.
    - z. First aid.
    - aa. Security.
    - bb. Progress cleaning.
  3. Minutes: Contractor will record and distribute meeting minutes.

- C. Progress Meetings: Conduct progress meetings at regular intervals to correspond with construction activity milestones as deemed appropriate by the contractor, but at least monthly.
1. Agenda: Review and correct or approve minutes of previous progress meeting. Review other items of significance that could affect progress. Include topics for discussion as appropriate to status of Project.
    - a. Contractor's Construction Schedule: Review progress since the last meeting. Determine whether each activity is on time, ahead of schedule, or behind schedule, in relation to Contractor's construction schedule. Determine how construction behind schedule will be expedited; secure commitments from parties involved to do so. Discuss whether schedule revisions are required to ensure that current and subsequent activities will be completed within the Contract Time.
      - 1) Review schedule for next period.
    - b. Review present and future needs of each entity present, including the following:
      - 1) Interface requirements.
      - 2) Sequence of operations.
      - 3) Status of submittals.
      - 4) Deliveries.
      - 5) Off-site fabrication.
      - 6) Access.
      - 7) Site use.
      - 8) Temporary facilities and controls.
      - 9) Progress cleaning.
      - 10) Quality and work standards.
      - 11) Status of correction of deficient items.
      - 12) Field observations.
      - 13) Status of RFIs.
      - 14) Status of Proposal Requests.
      - 15) Pending changes.
      - 16) Status of Change Orders.
      - 17) Pending claims and disputes.
      - 18) Documentation of information for payment requests.
  2. Minutes: Contractor will record and distribute the meeting minutes to each party present and to parties requiring information.

PART 2 - PRODUCTS (Not Used)

PART 3 - EXECUTION (Not Used)

END OF SECTION 01 31 00

## SECTION 01 33 00 - SUBMITTAL PROCEDURES

### PART 1 - GENERAL

#### 1.1 SUMMARY

A. Section Includes:

1. Submittal schedule requirements.
2. Administrative and procedural requirements for submittals.

#### 1.2 DEFINITIONS

- A. Action Submittals: Written and graphic information and physical samples that require Architect's responsive action. Action submittals are those submittals indicated in individual Specification Sections as "action submittals."
- B. Informational Submittals: Written and graphic information and physical samples that do not require Architect's responsive action. Submittals may be rejected for not complying with requirements. Informational submittals are those submittals indicated in individual Specification Sections as "informational submittals."

#### 1.3 SUBMITTAL SCHEDULE

- A. Submittal Schedule: Submit, as an action submittal, a list of submittals, arranged in chronological order by dates required by construction schedule. Include time required for review, ordering, manufacturing, fabrication, and delivery when establishing dates. Include additional time required for making corrections or revisions to submittals noted by Architect and additional time for handling and reviewing submittals required by those corrections.

#### 1.4 SUBMITTAL FORMATS

A. Submittal Information: Include the following information in each submittal:

1. Project name.
2. Date.
3. Name of Architect.
4. Name of Contractor.
5. Name of firm or entity that prepared submittal.
6. Names of subcontractor, manufacturer, and supplier.
7. Unique submittal number, including revision identifier. Include Specification Section number with sequential alphanumeric identifier; and alphanumeric suffix for resubmittals.
8. Category and type of submittal.
9. Submittal purpose and description.



10. Number and title of Specification Section, with paragraph number and generic name for each of multiple items.
  11. Drawing number and detail references, as appropriate.
  12. Indication of full or partial submittal.
  13. Location(s) where product is to be installed, as appropriate.
  14. Other necessary identification.
  15. Remarks.
  16. Signature of transmitter.
- B. Options: Identify options requiring selection by Architect.
- C. Deviations and Additional Information: On each submittal, clearly indicate deviations from requirements in the Contract Documents, including minor variations and limitations; include relevant additional information and revisions, other than those requested by Architect on previous submittals. Indicate by highlighting on each submittal or noting on attached separate sheet.
- D. Electronic Submittals: Prepare submittals as PDF package, incorporating complete information into each PDF file. Name PDF file with submittal number.

#### 1.5 SUBMITTAL PROCEDURES

- A. Prepare and submit submittals required by individual Specification Sections. Types of submittals are indicated in individual Specification Sections.
1. Email: Prepare submittals as PDF package, and transmit to Architect by sending via email. Include PDF transmittal form. Include information in email subject line as requested by Architect.
- B. Coordination: Coordinate preparation and processing of submittals with performance of construction activities.
1. Coordinate each submittal with fabrication, purchasing, testing, delivery, other submittals, and related activities that require sequential activity.
  2. Submit all submittal items required for each Specification Section concurrently unless partial submittals for portions of the Work are indicated on approved submittal schedule.
  3. Submit action submittals and informational submittals required by the same Specification Section as separate packages under separate transmittals.
- C. Processing Time: Allow time for submittal review, including time for resubmittals, as follows. Time for review shall commence on **Architect's** receipt of submittal. No extension of the Contract Time will be authorized because of failure to transmit submittals enough in advance of the Work to permit processing, including resubmittals.
1. Initial Review: Allow **10** days for initial review of each submittal. Allow additional time if coordination with subsequent submittals is required. **Architect** will advise Contractor when a submittal being processed must be delayed for coordination.
  2. Resubmittal Review: Allow **10** days for review of each resubmittal.

- D. Resubmittals: Make resubmittals in same form and number of copies as initial submittal.
- E. Distribution: Furnish copies of final submittals to manufacturers, subcontractors, suppliers, fabricators, installers, authorities having jurisdiction, and others as necessary for performance of construction activities. Show distribution on transmittal forms.
- F. Use for Construction: Retain complete copies of submittals on Project site. Use only final action submittals that are marked with approval notation from Architect's action stamp.

## 1.6 SUBMITTAL REQUIREMENTS

- A. Product Data: Collect information into a single submittal for each element of construction and type of product or equipment.
  - 1. If information must be specially prepared for submittal because standard published data are unsuitable for use, submit as Shop Drawings, not as Product Data.
  - 2. Mark each copy of each submittal to show which products and options are applicable.
  - 3. Include the following information, as applicable:
    - a. Manufacturer's catalog cuts.
    - b. Manufacturer's product specifications.
    - c. Standard color charts.
    - d. Statement of compliance with specified referenced standards.
    - e. Testing by recognized testing agency.
    - f. Application of testing agency labels and seals.
    - g. Notation of coordination requirements.
    - h. Availability and delivery time information.
  - 4. For equipment, include the following in addition to the above, as applicable:
    - a. Wiring diagrams that show factory-installed wiring.
    - b. Printed performance curves.
    - c. Operational range diagrams.
    - d. Clearances required to other construction, if not indicated on accompanying Shop Drawings.
  - 5. Submit Product Data before Shop Drawings, and before or concurrent with Samples.
- B. Shop Drawings: Prepare Project-specific information, drawn accurately to scale. Do not base Shop Drawings on reproductions of the Contract Documents or standard printed data.
  - 1. Preparation: Fully illustrate requirements in the Contract Documents. Include the following information, as applicable:

- a. Identification of products.
  - b. Schedules.
  - c. Compliance with specified standards.
  - d. Notation of coordination requirements.
  - e. Notation of dimensions established by field measurement.
  - f. Relationship and attachment to adjoining construction clearly indicated.
  - g. Seal and signature of professional engineer if specified.
2. Paper Sheet Size: Except for templates, patterns, and similar full-size Drawings, submit Shop Drawings on sheets at least 8-1/2 by 11 inches, but no larger than 30 by 42 inches.
- C. Samples: Submit Samples for review of kind, color, pattern, and texture for a check of these characteristics with other materials.
1. Transmit Samples that contain multiple, related components such as accessories together in one submittal package.
  2. Identification: Permanently attach label on unexposed side of Samples that includes the following:
    - a. Project name and submittal number.
    - b. Generic description of Sample.
    - c. Product name and name of manufacturer.
    - d. Sample source.
    - e. Number and title of applicable Specification Section.
    - f. Specification paragraph number and generic name of each item.
  3. Email Transmittal: Provide PDF transmittal. Include digital image file illustrating Sample characteristics, and identification information for record.
  4. Disposition: Maintain sets of approved Samples at Project site, available for quality-control comparisons throughout the course of construction activity. Sample sets may be used to determine final acceptance of construction associated with each set.
    - a. Samples that may be incorporated into the Work are indicated in individual Specification Sections. Such Samples must be in an undamaged condition at time of use.
    - b. Samples not incorporated into the Work, or otherwise designated as Owner's property, are the property of Contractor.
  5. Samples for Initial Selection: Submit manufacturer's color charts consisting of units or sections of units showing the full range of colors, textures, and patterns available.
    - a. Number of Samples: Submit **one** full set(s) of available choices where color, pattern, texture, or similar characteristics are required to be selected from manufacturer's product line. Architect will return submittal with options selected.
  6. Samples for Verification: Submit full-size units or Samples of size indicated, prepared from same material to be used for the Work, cured and finished in

manner specified, and physically identical with material or product proposed for use, and that show full range of color and texture variations expected. Samples include, but are not limited to, the following: partial sections of manufactured or fabricated components; small cuts or containers of materials; complete units of repetitively used materials; swatches showing color, texture, and pattern; color range sets; and components used for independent testing and inspection.

- a. Number of Samples: Submit **three** sets of Samples. Architect will retain two Sample sets; remainder will be returned.
- D. Product Schedule: As required in individual Specification Sections, prepare a written summary indicating types of products required for the Work and their intended location. Include the following information in tabular form:
- E. Qualification Data: Prepare written information that demonstrates capabilities and experience of firm or person. Include lists of completed projects with project names and addresses, contact information of architects and owners, and other information specified.
- F. Design Data: Prepare and submit written and graphic information indicating compliance with indicated performance and design criteria in individual Specification Sections. Include list of assumptions and summary of loads. Include load diagrams if applicable. Provide name and version of software, if any, used for calculations. Number each page of submittal.
- G. Certificates:
1. Certificates and Certifications Submittals: Submit a statement that includes signature of entity responsible for preparing certification. Certificates and certifications shall be signed by an officer or other individual authorized to sign documents on behalf of that entity. Provide a notarized signature where indicated.
  2. Installer Certificates: Submit written statements on manufacturer's letterhead certifying that Installer complies with requirements in the Contract Documents and, where required, is authorized by manufacturer for this specific Project.
  3. Manufacturer Certificates: Submit written statements on manufacturer's letterhead certifying that manufacturer complies with requirements in the Contract Documents. Include evidence of manufacturing experience where required.
  4. Material Certificates: Submit written statements on manufacturer's letterhead certifying that material complies with requirements in the Contract Documents.
  5. Product Certificates: Submit written statements on manufacturer's letterhead certifying that product complies with requirements in the Contract Documents.
  6. Welding Certificates: Prepare written certification that welding procedures and personnel comply with requirements in the Contract Documents. Submit record of Welding Procedure Specification and Procedure Qualification Record on AWS forms. Include names of firms and personnel certified.
- H. Test and Research Reports:

1. Compatibility Test Reports: Submit reports written by a qualified testing agency, on testing agency's standard form, indicating and interpreting results of compatibility tests performed before installation of product. Include written recommendations for substrate preparation and primers required.
2. Field Test Reports: Submit written reports indicating and interpreting results of field tests performed either during installation of product or after product is installed in its final location, for compliance with requirements in the Contract Documents.
3. Material Test Reports: Submit reports written by a qualified testing agency, on testing agency's standard form, indicating and interpreting test results of material for compliance with requirements in the Contract Documents.
4. Preconstruction Test Reports: Submit reports written by a qualified testing agency, on testing agency's standard form, indicating and interpreting results of tests performed before installation of product, for compliance with performance requirements in the Contract Documents.
5. Product Test Reports: Submit written reports indicating that current product produced by manufacturer complies with requirements in the Contract Documents. Base reports on evaluation of tests performed by manufacturer and witnessed by a qualified testing agency, or on comprehensive tests performed by a qualified testing agency.
6. Research Reports: Submit written evidence, from a model code organization acceptable to authorities having jurisdiction, that product complies with building code in effect for Project. Include the following information:
  - a. Name of evaluation organization.
  - b. Date of evaluation.
  - c. Time period when report is in effect.
  - d. Product and manufacturers' names.
  - e. Description of product.
  - f. Test procedures and results.
  - g. Limitations of use.

#### 1.7 DELEGATED-DESIGN SERVICES

- A. Performance and Design Criteria: Where professional design services or certifications by a design professional are specifically required of Contractor by the Contract Documents, provide products and systems complying with specific performance and design criteria indicated.
  1. If criteria indicated are insufficient to perform services or certification required, submit a written request for additional information to Architect.
- B. Delegated-Design Services Certification: In addition to Shop Drawings, Product Data, and other required submittals, submit paper copies of certificate, signed and sealed by the responsible design professional, for each product and system specifically assigned to Contractor to be designed or certified by a design professional.
  1. Indicate that products and systems comply with performance and design criteria in the Contract Documents. Include list of codes, loads, and other factors used in performing these services.

#### 1.8 CONTRACTOR'S REVIEW

- A. Action Submittals and Informational Submittals: Review each submittal and check for coordination with other Work of the Contract and for compliance with the Contract Documents. Note corrections and field dimensions. Mark with approval stamp before submitting to Architect.
- B. Contractor's Approval: Indicate Contractor's approval for each submittal with a uniform approval stamp. Include name of reviewer, date of Contractor's approval, and statement certifying that submittal has been reviewed, checked, and approved for compliance with the Contract Documents.
  - 1. Architect will not review submittals received from Contractor that do not have Contractor's review and approval.

#### 1.9 ARCHITECT'S REVIEW

- A. Action Submittals: Architect will review each submittal, indicate corrections or revisions required, and return it.
  - 1. PDF Submittals: Architect will indicate, via markup on each submittal, the appropriate action.
- B. Informational Submittals: Architect will review each submittal and will not return it, or will return it if it does not comply with requirements. Architect will forward each submittal to appropriate party.
- C. Partial submittals prepared for a portion of the Work will be reviewed when use of partial submittals has received prior approval from Architect.
- D. Incomplete submittals are unacceptable, will be considered nonresponsive, and will be returned for resubmittal without review.
- E. Architect will return without review submittals received from sources other than Contractor.
- F. Submittals not required by the Contract Documents will be returned by Architect without action.

PART 2 - PRODUCTS (Not Used)

PART 3 - EXECUTION (Not Used)

END OF SECTION 01 33 00



## SECTION 01 74 19 - CONSTRUCTION WASTE MANAGEMENT AND DISPOSAL

### PART 1 - GENERAL

#### 1.1 SUMMARY

- A. Section includes administrative and procedural requirements for the following:
  - 1. Salvaging nonhazardous demolition and construction waste.
  - 2. Recycling nonhazardous demolition and construction waste.
  - 3. Disposing of nonhazardous demolition and construction waste.
- B. Related Requirements:
  - 1. Section 04 20 00 "Unit Masonry" for disposal requirements for masonry waste.
  - 2. Section 31 10 00 "Site Clearing" for disposition of waste resulting from site clearing and removal of above- and below-grade improvements.

#### 1.2 DEFINITIONS

- A. Construction Waste: Building, structure, and site improvement materials and other solid waste resulting from construction, remodeling, renovation, or repair operations. Construction waste includes packaging.
- B. Demolition Waste: Building, structure, and site improvement materials resulting from demolition operations.
- C. Disposal: Removal of demolition or construction waste and subsequent salvage, sale, recycling, or deposit in landfill, incinerator acceptable to authorities having jurisdiction, or designated spoil areas on Owner's property.
- D. Recycle: Recovery of demolition or construction waste for subsequent processing in preparation for reuse.
- E. Salvage: Recovery of demolition or construction waste and subsequent sale or reuse in another facility.
- F. Salvage and Reuse: Recovery of demolition or construction waste and subsequent incorporation into the Work.

#### 1.3 ACTION SUBMITTALS

- A. Waste Management Plan: Submit plan within 7 days of the Notice to Proceed.
- B. Recycling and Processing Facility Records: Indicate receipt and acceptance of recyclable waste by recycling and processing facilities licensed to accept them. Include manifests, weight tickets, receipts, and invoices.

- C. Landfill and Incinerator Disposal Records: Indicate receipt and acceptance of waste by landfills and incinerator facilities licensed to accept them. Include manifests, weight tickets, receipts, and invoices.

#### 1.4 WASTE MANAGEMENT PLAN

- A. General: Develop a waste management plan according to requirements in this Section. Plan shall consist of waste identification, waste reduction work plan, and cost/revenue analysis. Distinguish between demolition and construction waste. Indicate quantities by weight or volume, but use same units of measure throughout waste management plan.

### PART 2 - PRODUCTS

#### 2.1 PERFORMANCE REQUIREMENTS

- A. General: Achieve end-of-Project rates for salvage/recycling of 50 percent by weight of total nonhazardous solid waste generated by the Work. Facilitate recycling and salvage of materials.

### PART 3 - EXECUTION

#### 3.1 PLAN IMPLEMENTATION

- A. General: Implement approved waste management plan. Provide handling, containers, storage, signage, transportation, and other items as required to implement waste management plan during the entire duration of the Contract.

#### 3.2 RECYCLING DEMOLITION AND CONSTRUCTION WASTE, GENERAL

- A. General: Recycle paper and beverage containers used by on-site workers.
- B. Recycling Incentives: Revenues, savings, rebates, tax credits, and other incentives received for recycling waste materials shall accrue to Contractor.
- C. Preparation of Waste: Prepare and maintain recyclable waste materials according to recycling or reuse facility requirements. Maintain materials free of dirt, adhesives, solvents, petroleum contamination, and other substances deleterious to the recycling process.
- D. Procedures: Separate recyclable waste from other waste materials, trash, and debris. Separate recyclable waste by type at Project site to the maximum extent practical according to approved construction waste management plan.
  - 1. Provide appropriately marked containers or bins for controlling recyclable waste until removed from Project site. Include list of acceptable and unacceptable materials at each container and bin.

- a. Inspect containers and bins for contamination and remove contaminated materials if found.
2. Stockpile processed materials on-site without intermixing with other materials. Place, grade, and shape stockpiles to drain surface water. Cover to prevent windblown dust.
3. Stockpile materials away from construction area. Do not store within drip line of remaining trees.
4. Store components off the ground and protect from the weather.
5. Remove recyclable waste from Owner's property and transport to recycling receiver or processor as often as required to prevent overfilling bins.

### 3.3 RECYCLING DEMOLITION WASTE

- A. Asphalt Paving: Break up and transport paving to asphalt-recycling facility.
- B. Concrete: Remove reinforcement and other metals from concrete and sort with other metals.
  1. Pulverize concrete to maximum 1-1/2-inch size.
- C. Masonry: Remove metal reinforcement, anchors, and ties from masonry and sort with other metals.
  1. Pulverize masonry to maximum 1-1/2-inch size.
  2. Clean and stack undamaged, whole masonry units on wood pallets.
- D. Metals: Separate metals by type.
  1. Structural Steel: Stack members according to size, type of member, and length.
  2. Remove and dispose of bolts, nuts, washers, and other rough hardware.
- E. Piping: Reduce piping to straight lengths and store by material and size. Separate supports, hangers, valves, sprinklers, and other components by material and size.
- F. Conduit: Reduce conduit to straight lengths and store by material and size.
- G. Lamps: Separate lamps by type and store according to requirements in 40 CFR 273.

### 3.4 RECYCLING CONSTRUCTION WASTE

- A. Packaging:
  1. Cardboard and Boxes: Break down packaging into flat sheets. Bundle and store in a dry location.
  2. Polystyrene Packaging: Separate and bag materials.
  3. Pallets: As much as possible, require deliveries using pallets to remove pallets from Project site. For pallets that remain on-site, break down pallets into component wood pieces and comply with requirements for recycling wood.

4. Crates: Break down crates into component wood pieces and comply with requirements for recycling wood.
- B. Wood Materials:
1. Clean Cut-Offs of Lumber: Grind or chip into small pieces.
  2. Clean Sawdust: Bag sawdust that does not contain painted or treated wood.
- C. Gypsum Board: Stack large clean pieces on wood pallets or in container and store in a dry location.
1. Clean Gypsum Board: Grind scraps of clean gypsum board using small mobile chipper or hammer mill. Screen out paper after grinding.
- D. Paint: Seal containers and store by type.

### 3.5 DISPOSAL OF WASTE

- A. General: Except for items or materials to be salvaged or recycled, remove waste materials from Project site and legally dispose of them in a landfill or incinerator acceptable to authorities having jurisdiction.
1. Except as otherwise specified, do not allow waste materials that are to be disposed of accumulate on-site.
  2. Remove and transport debris in a manner that will prevent spillage on adjacent surfaces and areas.
- B. General: Except for items or materials to be salvaged or recycled, remove waste materials and legally dispose of at designated spoil areas on Owner's property.
- C. Burning: Do not burn waste materials.

END OF SECTION 01 74 19

# DRAFT AIA® Document A201® - 2017

## General Conditions of the Contract for Construction

for the following PROJECT:  
(Name and location or address)

«Maintenance Facility Expansion»  
«Evansville, WI»

THE OWNER:  
(Name, legal status and address)

«City of Evansville»«», Other»  
«31 S. Madison St.  
Evansville, WI 53536»

THE ARCHITECT:  
(Name, legal status and address)

«Sketchworks Architecture, LLC»«», Limited Liability Company»  
«7780 Elmwood Ave.  
suite 208  
Middleton, WI 53562»

### TABLE OF ARTICLES

- 1 GENERAL PROVISIONS
- 2 OWNER
- 3 CONTRACTOR
- 4 ARCHITECT
- 5 SUBCONTRACTORS
- 6 CONSTRUCTION BY OWNER OR BY SEPARATE CONTRACTORS
- 7 CHANGES IN THE WORK
- 8 TIME
- 9 PAYMENTS AND COMPLETION
- 10 PROTECTION OF PERSONS AND PROPERTY
- 11 INSURANCE AND BONDS
- 12 UNCOVERING AND CORRECTION OF WORK
- 13 MISCELLANEOUS PROVISIONS

**ADDITIONS AND DELETIONS:**  
The author of this document has added information needed for its completion. The author may also have revised the text of the original AIA standard form. An *Additions and Deletions Report* that notes added information as well as revisions to the standard form text is available from the author and should be reviewed.

This document has important legal consequences. Consultation with an attorney is encouraged with respect to its completion or modification.

For guidance in modifying this document to include supplementary conditions, see AIA Document A503™, Guide for Supplementary Conditions.

**ELECTRONIC COPYING** of any portion of this AIA® Document to another electronic file is prohibited and constitutes a violation of copyright laws as set forth in the footer of this document.

- 14 TERMINATION OR SUSPENSION OF THE CONTRACT
- 15 CLAIMS AND DISPUTES





## INDEX

(Topics and numbers in bold are Section headings.)

### **Acceptance of Nonconforming Work**

9.6.6, 9.9.3, **12.3**

Acceptance of Work

9.6.6, 9.8.2, 9.9.3, 9.10.1, 9.10.3, 12.3

### **Access to Work**

**3.16**, 6.2.1, 12.1

Accident Prevention

10

Acts and Omissions

3.2, 3.3.2, 3.12.8, 3.18, 4.2.3, 8.3.1, 9.5.1, 10.2.5,

10.2.8, 13.3.2, 14.1, 15.1.2, 15.2

Addenda

1.1.1

Additional Costs, Claims for

3.7.4, 3.7.5, 10.3.2, 15.1.5

### **Additional Inspections and Testing**

9.4.2, 9.8.3, 12.2.1, **13.4**

### **Additional Time, Claims for**

3.2.4, 3.7.4, 3.7.5, 3.10.2, 8.3.2, **15.1.6**

### **Administration of the Contract**

3.1.3, **4.2**, 9.4, 9.5

Advertisement or Invitation to Bid

1.1.1

Aesthetic Effect

4.2.13

### **Allowances**

**3.8**

### **Applications for Payment**

4.2.5, 7.3.9, 9.2, **9.3**, 9.4, 9.5.1, 9.5.4, 9.6.3, 9.7, 9.10

Approvals

2.1.1, 2.3.1, 2.5, 3.1.3, 3.10.2, 3.12.8, 3.12.9,

3.12.10.1, 4.2.7, 9.3.2, 13.4.1

### **Arbitration**

8.3.1, 15.3.2, **15.4**

## **ARCHITECT**

**4**

**Architect**, Definition of

**4.1.1**

Architect, Extent of Authority

2.5, 3.12.7, 4.1.2, 4.2, 5.2, 6.3, 7.1.2, 7.3.4, 7.4, 9.2,

9.3.1, 9.4, 9.5, 9.6.3, 9.8, 9.10.1, 9.10.3, 12.1, 12.2.1,

13.4.1, 13.4.2, 14.2.2, 14.2.4, 15.1.4, 15.2.1

Architect, Limitations of Authority and

Responsibility

2.1.1, 3.12.4, 3.12.8, 3.12.10, 4.1.2, 4.2.1, 4.2.2,

4.2.3, 4.2.6, 4.2.7, 4.2.10, 4.2.12, 4.2.13, 5.2.1, 7.4,

9.4.2, 9.5.4, 9.6.4, 15.1.4, 15.2

Architect's Additional Services and Expenses

2.5, 12.2.1, 13.4.2, 13.4.3, 14.2.4

Architect's Administration of the Contract

3.1.3, 3.7.4, 15.2, 9.4.1, 9.5

Architect's Approvals

2.5, 3.1.3, 3.5, 3.10.2, 4.2.7

Architect's Authority to Reject Work

3.5, 4.2.6, 12.1.2, 12.2.1

Architect's Copyright

1.1.7, 1.5

Architect's Decisions

3.7.4, 4.2.6, 4.2.7, 4.2.11, 4.2.12, 4.2.13, 4.2.14, 6.3,

7.3.4, 7.3.9, 8.1.3, 8.3.1, 9.2, 9.4.1, 9.5, 9.8.4, 9.9.1,

13.4.2, 15.2

Architect's Inspections

3.7.4, 4.2.2, 4.2.9, 9.4.2, 9.8.3, **9.9.2**, 9.10.1, 13.4

Architect's Instructions

3.2.4, 3.3.1, 4.2.6, 4.2.7, 13.4.2

Architect's Interpretations

4.2.11, 4.2.12

Architect's Project Representative

4.2.10

Architect's Relationship with Contractor

1.1.2, 1.5, 2.3.3, 3.1.3, 3.2.2, 3.2.3, 3.2.4, 3.3.1, 3.4.2,

3.5, 3.7.4, 3.7.5, 3.9.2, 3.9.3, 3.10, 3.11, 3.12, 3.16,

3.18, 4.1.2, 4.2, 5.2, 6.2.2, 7, 8.3.1, 9.2, 9.3, 9.4, 9.5,

9.7, 9.8, 9.9, 10.2.6, 10.3, 11.3, 12, 13.3.2, 13.4, 15.2

Architect's Relationship with Subcontractors

1.1.2, 4.2.3, 4.2.4, 4.2.6, 9.6.3, 9.6.4, 11.3

Architect's Representations

9.4.2, 9.5.1, 9.10.1

Architect's Site Visits

3.7.4, 4.2.2, 4.2.9, 9.4.2, 9.5.1, **9.9.2**, 9.10.1, 13.4

Asbestos

10.3.1

Attorneys' Fees

3.18.1, 9.6.8, 9.10.2, 10.3.3

Award of Separate Contracts

6.1.1, 6.1.2

### **Award of Subcontracts and Other Contracts for**

**Portions of the Work**

**5.2**

### **Basic Definitions**

**1.1**

Bidding Requirements

1.1.1

Binding Dispute Resolution

8.3.1, 9.7, 11.5, 13.1, 15.1.2, 15.1.3, 15.2.1, 15.2.5,

15.2.6.1, 15.3.1, 15.3.2, 15.3.3, 15.4.1

Bonds, Lien

7.3.4.4, 9.6.8, 9.10.2, 9.10.3

### **Bonds, Performance, and Payment**

7.3.4.4, 9.6.7, 9.10.3, **11.1.2**, **11.1.3**, **11.5**

### **Building Information Models Use and Reliance**

**1.8**

Building Permit

3.7.1

### **Capitalization**

**1.3**

Certificate of Substantial Completion

9.8.3, 9.8.4, 9.8.5

### **Certificates for Payment**

4.2.1, 4.2.5, 4.2.9, 9.3.3, **9.4**, 9.5, 9.6.1, 9.6.6, 9.7,

9.10.1, 9.10.3, 14.1.1.3, 14.2.4, 15.1.4

Certificates of Inspection, Testing or Approval  
13.4.4  
Certificates of Insurance  
9.10.2  
**Change Orders**  
1.1.1, 3.4.2, 3.7.4, 3.8.2.3, 3.11, 3.12.8, 4.2.8, 5.2.3,  
7.1.2, 7.1.3, **7.2**, 7.3.2, 7.3.7, 7.3.9, 7.3.10, 8.3.1,  
9.3.1.1, 9.10.3, 10.3.2, 11.2, 11.5, 12.1.2  
**Change Orders**, Definition of  
**7.2.1**  
**CHANGES IN THE WORK**  
2.2.2, 3.11, 4.2.8, **7**, 7.2.1, 7.3.1, 7.4, 8.3.1, 9.3.1.1,  
11.5  
**Claims**, Definition of  
**15.1.1**  
Claims, Notice of  
1.6.2, 15.1.3  
**CLAIMS AND DISPUTES**  
3.2.4, 6.1.1, 6.3, 7.3.9, 9.3.3, 9.10.4, 10.3.3, **15**, 15.4  
Claims and Timely Assertion of Claims  
15.4.1  
**Claims for Additional Cost**  
3.2.4, 3.3.1, 3.7.4, 7.3.9, 9.5.2, 10.2.5, 10.3.2, **15.1.5**  
**Claims for Additional Time**  
3.2.4, 3.3.1, 3.7.4, 6.1.1, 8.3.2, 9.5.2, 10.3.2, **15.1.6**  
**Concealed or Unknown Conditions, Claims for**  
**3.7.4**  
Claims for Damages  
3.2.4, 3.18, 8.3.3, 9.5.1, 9.6.7, 10.2.5, 10.3.3, 11.3,  
11.3.2, 14.2.4, 15.1.7  
Claims Subject to Arbitration  
15.4.1  
**Cleaning Up**  
**3.15**, 6.3  
Commencement of the Work, Conditions Relating to  
2.2.1, 3.2.2, 3.4.1, 3.7.1, 3.10.1, 3.12.6, 5.2.1, 5.2.3,  
6.2.2, 8.1.2, 8.2.2, 8.3.1, 11.1, 11.2, **15.1.5**  
**Commencement of the Work**, Definition of  
**8.1.2**  
**Communications**  
3.9.1, **4.2.4**  
Completion, Conditions Relating to  
3.4.1, 3.11, 3.15, 4.2.2, 4.2.9, 8.2, 9.4.2, 9.8, 9.9.1,  
9.10, 12.2, 14.1.2, 15.1.2  
**COMPLETION, PAYMENTS AND**  
**9**  
Completion, Substantial  
3.10.1, 4.2.9, 8.1.1, 8.1.3, 8.2.3, 9.4.2, 9.8, 9.9.1,  
9.10.3, 12.2, 15.1.2  
Compliance with Laws  
2.3.2, 3.2.3, 3.6, 3.7, 3.12.10, 3.13, 9.6.4, 10.2.2,  
13.1, 13.3, 13.4.1, 13.4.2, 13.5, 14.1.1, 14.2.1.3,  
15.2.8, 15.4.2, 15.4.3  
Concealed or Unknown Conditions  
3.7.4, 4.2.8, 8.3.1, 10.3  
Conditions of the Contract  
1.1.1, 6.1.1, 6.1.4

Consent, Written  
3.4.2, 3.14.2, 4.1.2, 9.8.5, 9.9.1, 9.10.2, 9.10.3, 13.2,  
15.4.4.2  
**Consolidation or Joinder**  
**15.4.4**  
**CONSTRUCTION BY OWNER OR BY**  
**SEPARATE CONTRACTORS**  
1.1.4, **6**  
**Construction Change Directive**, Definition of  
**7.3.1**  
**Construction Change Directives**  
1.1.1, 3.4.2, 3.11, 3.12.8, 4.2.8, 7.1.1, 7.1.2, 7.1.3,  
**7.3**, 9.3.1.1  
Construction Schedules, Contractor's  
3.10, 3.11, 3.12.1, 3.12.2, 6.1.3, 15.1.6.2  
**Contingent Assignment of Subcontracts**  
**5.4**, 14.2.2.2  
**Continuing Contract Performance**  
**15.1.4**  
**Contract**, Definition of  
**1.1.2**  
**CONTRACT, TERMINATION OR**  
**SUSPENSION OF THE**  
5.4.1.1, 5.4.2, 11.5, **14**  
Contract Administration  
3.1.3, 4, 9.4, 9.5  
Contract Award and Execution, Conditions Relating  
to  
3.7.1, 3.10, 5.2, 6.1  
Contract Documents, Copies Furnished and Use of  
1.5.2, 2.3.6, 5.3  
**Contract Documents**, Definition of  
**1.1.1**  
**Contract Sum**  
2.2.2, 2.2.4, 3.7.4, 3.7.5, 3.8, 3.10.2, 5.2.3, 7.3, 7.4,  
**9.1**, 9.2, 9.4.2, 9.5.1.4, 9.6.7, 9.7, 10.3.2, 11.5, 12.1.2,  
12.3, 14.2.4, 14.3.2, 15.1.4.2, **15.1.5**, **15.2.5**  
**Contract Sum**, Definition of  
**9.1**  
Contract Time  
1.1.4, 2.2.1, 2.2.2, 3.7.4, 3.7.5, 3.10.2, 5.2.3, 6.1.5,  
7.2.1.3, 7.3.1, 7.3.5, 7.3.6, 7, 7, 7.3.10, 7.4, 8.1.1,  
8.2.1, 8.2.3, 8.3.1, 9.5.1, 9.7, 10.3.2, 12.1.1, 12.1.2,  
14.3.2, 15.1.4.2, 15.1.6.1, 15.2.5  
**Contract Time**, Definition of  
8.1.1  
**CONTRACTOR**  
**3**  
Contractor, Definition of  
**3.1**, **6.1.2**  
**Contractor's Construction and Submittal**  
**Schedules**  
**3.10**, 3.12.1, 3.12.2, 4.2.3, 6.1.3, 15.1.6.2  
Contractor's Employees  
2.2.4, 3.3.2, 3.4.3, 3.8.1, 3.9, 3.18.2, 4.2.3, 4.2.6,  
10.2, 10.3, 11.3, 14.1, 14.2.1.1  
**Contractor's Liability Insurance**  
**11.1**

Contractor's Relationship with Separate Contractors and Owner's Forces  
3.12.5, 3.14.2, 4.2.4, 6, 11.3, 12.2.4  
Contractor's Relationship with Subcontractors  
1.2.2, 2.2.4, 3.3.2, 3.18.1, 3.18.2, 4.2.4, 5, 9.6.2, 9.6.7, 9.10.2, 11.2, 11.3, 11.4  
Contractor's Relationship with the Architect  
1.1.2, 1.5, 2.3.3, 3.1.3, 3.2.2, 3.2.3, 3.2.4, 3.3.1, 3.4.2, 3.5.1, 3.7.4, 3.10, 3.11, 3.12, 3.16, 3.18, 4.2, 5.2, 6.2.2, 7, 8.3.1, 9.2, 9.3, 9.4, 9.5, 9.7, 9.8, 9.9, 10.2.6, 10.3, 11.3, 12, 13.4, 15.1.3, 15.2.1  
Contractor's Representations  
3.2.1, 3.2.2, 3.5, 3.12.6, 6.2.2, 8.2.1, 9.3.3, 9.8.2  
Contractor's Responsibility for Those Performing the Work  
3.3.2, 3.18, 5.3, 6.1.3, 6.2, 9.5.1, 10.2.8  
Contractor's Review of Contract Documents  
3.2  
Contractor's Right to Stop the Work  
2.2.2, 9.7  
Contractor's Right to Terminate the Contract  
14.1  
Contractor's Submittals  
3.10, 3.11, 3.12, 4.2.7, 5.2.1, 5.2.3, 9.2, 9.3, 9.8.2, 9.8.3, 9.9.1, 9.10.2, 9.10.3  
Contractor's Superintendent  
3.9, 10.2.6  
Contractor's Supervision and Construction Procedures  
1.2.2, 3.3, 3.4, 3.12.10, 4.2.2, 4.2.7, 6.1.3, 6.2.4, 7.1.3, 7.3.4, 7.3.6, 8.2, 10, 12, 14, 15.1.4  
Coordination and Correlation  
1.2, 3.2.1, 3.3.1, 3.10, 3.12.6, 6.1.3, 6.2.1  
Copies Furnished of Drawings and Specifications  
1.5, 2.3.6, 3.11  
Copyrights  
1.5, **3.17**  
Correction of Work  
2.5, 3.7.3, 9.4.2, 9.8.2, 9.8.3, 9.9.1, 12.1.2, **12.2**, 12.3, 15.1.3.1, 15.1.3.2, 15.2.1  
**Correlation and Intent of the Contract Documents**  
**1.2**  
**Cost**, Definition of  
**7.3.4**  
Costs  
2.5, 3.2.4, 3.7.3, 3.8.2, 3.15.2, 5.4.2, 6.1.1, 6.2.3, 7.3.3.3, 7.3.4, 7.3.8, 7.3.9, 9.10.2, 10.3.2, 10.3.6, 11.2, 12.1.2, 12.2.1, 12.2.4, 13.4, 14  
**Cutting and Patching**  
**3.14**, 6.2.5  
Damage to Construction of Owner or Separate Contractors  
3.14.2, 6.2.4, 10.2.1.2, 10.2.5, 10.4, 12.2.4  
Damage to the Work  
3.14.2, 9.9.1, 10.2.1.2, 10.2.5, 10.4, 12.2.4  
Damages, Claims for  
3.2.4, 3.18, 6.1.1, 8.3.3, 9.5.1, 9.6.7, 10.3.3, 11.3.2, 11.3, 14.2.4, 15.1.7

Damages for Delay  
6.2.3, 8.3.3, 9.5.1.6, 9.7, 10.3.2, 14.3.2  
**Date of Commencement of the Work**, Definition of  
**8.1.2**  
**Date of Substantial Completion**, Definition of  
**8.1.3**  
**Day**, Definition of  
**8.1.4**  
Decisions of the Architect  
3.7.4, 4.2.6, 4.2.7, 4.2.11, 4.2.12, 4.2.13, 6.3, 7.3.4, 7.3.9, 8.1.3, 8.3.1, 9.2, 9.4, 9.5.1, 9.8.4, 9.9.1, 13.4.2, 14.2.2, 14.2.4, 15.1, 15.2  
**Decisions to Withhold Certification**  
9.4.1, **9.5**, 9.7, 14.1.1.3  
Defective or Nonconforming Work, Acceptance, Rejection and Correction of  
2.5, 3.5, 4.2.6, 6.2.3, 9.5.1, 9.5.3, 9.6.6, 9.8.2, 9.9.3, 9.10.4, 12.2.1  
Definitions  
1.1, 2.1.1, 3.1.1, 3.5, 3.12.1, 3.12.2, 3.12.3, 4.1.1, 5.1, 6.1.2, 7.2.1, 7.3.1, 8.1, 9.1, 9.8.1, 15.1.1  
**Delays and Extensions of Time**  
**3.2**, **3.7.4**, 5.2.3, 7.2.1, 7.3.1, **7.4**, **8.3**, **9.5.1**, **9.7**, 10.3.2, **10.4**, 14.3.2, **15.1.6**, 15.2.5  
**Digital Data Use and Transmission**  
**1.7**  
Disputes  
6.3, 7.3.9, 15.1, 15.2  
**Documents and Samples at the Site**  
**3.11**  
**Drawings**, Definition of  
**1.1.5**  
Drawings and Specifications, Use and Ownership of  
3.11  
Effective Date of Insurance  
8.2.2  
**Emergencies**  
**10.4**, 14.1.1.2, **15.1.5**  
Employees, Contractor's  
3.3.2, 3.4.3, 3.8.1, 3.9, 3.18.2, 4.2.3, 4.2.6, 10.2, 10.3.3, 11.3, 14.1, 14.2.1.1  
Equipment, Labor, or Materials  
1.1.3, 1.1.6, 3.4, 3.5, 3.8.2, 3.8.3, 3.12, 3.13, 3.15.1, 4.2.6, 4.2.7, 5.2.1, 6.2.1, 7.3.4, 9.3.2, 9.3.3, 9.5.1.3, 9.10.2, 10.2.1, 10.2.4, 14.2.1.1, 14.2.1.2  
Execution and Progress of the Work  
1.1.3, 1.2.1, 1.2.2, 2.3.4, 2.3.6, 3.1, 3.3.1, 3.4.1, 3.7.1, 3.10.1, 3.12, 3.14, 4.2, 6.2.2, 7.1.3, 7.3.6, 8.2, 9.5.1, 9.9.1, 10.2, 10.3, 12.1, 12.2, 14.2, 14.3.1, 15.1.4  
Extensions of Time  
3.2.4, 3.7.4, 5.2.3, 7.2.1, 7.3, 7.4, 9.5.1, 9.7, 10.3.2, 10.4, 14.3, 15.1.6, **15.2.5**  
**Failure of Payment**  
9.5.1.3, **9.7**, 9.10.2, 13.5, 14.1.1.3, 14.2.1.2  
Faulty Work  
(See Defective or Nonconforming Work)  
**Final Completion and Final Payment**  
4.2.1, 4.2.9, 9.8.2, **9.10**, 12.3, 14.2.4, 14.4.3

Financial Arrangements, Owner's

2.2.1, 13.2.2, 14.1.1.4

## **GENERAL PROVISIONS**

### **1**

#### **Governing Law**

##### **13.1**

Guarantees (See Warranty)

#### **Hazardous Materials and Substances**

10.2.4, **10.3**

Identification of Subcontractors and Suppliers

5.2.1

#### **Indemnification**

3.17, **3.18**, 9.6.8, 9.10.2, 10.3.3, 11.3

#### **Information and Services Required of the Owner**

2.1.2, **2.2**, 2.3, 3.2.2, 3.12.10.1, 6.1.3, 6.1.4, 6.2.5,

9.6.1, 9.9.2, 9.10.3, 10.3.3, 11.2, 13.4.1, 13.4.2,

14.1.1.4, 14.1.4, 15.1.4

#### **Initial Decision**

##### **15.2**

#### **Initial Decision Maker, Definition of**

1.1.8

Initial Decision Maker, Decisions

14.2.4, 15.1.4.2, 15.2.1, 15.2.2, 15.2.3, 15.2.4, 15.2.5

Initial Decision Maker, Extent of Authority

14.2.4, 15.1.4.2, 15.2.1, 15.2.2, 15.2.3, 15.2.4, 15.2.5

#### **Injury or Damage to Person or Property**

**10.2.8**, 10.4

Inspections

3.1.3, 3.3.3, 3.7.1, 4.2.2, 4.2.6, 4.2.9, 9.4.2, 9.8.3,

9.9.2, 9.10.1, 12.2.1, 13.4

Instructions to Bidders

1.1.1

Instructions to the Contractor

3.2.4, 3.3.1, 3.8.1, 5.2.1, 7, 8.2.2, 12, 13.4.2

#### **Instruments of Service, Definition of**

##### **1.1.7**

Insurance

6.1.1, 7.3.4, 8.2.2, 9.3.2, 9.8.4, 9.9.1, 9.10.2, 10.2.5,

##### **11**

Insurance, Notice of Cancellation or Expiration

11.1.4, 11.2.3

#### **Insurance, Contractor's Liability**

##### **11.1**

Insurance, Effective Date of

8.2.2, 14.4.2

#### **Insurance, Owner's Liability**

##### **11.2**

#### **Insurance, Property**

**10.2.5**, 11.2, 11.4, 11.5

Insurance, Stored Materials

9.3.2

## **INSURANCE AND BONDS**

### **11**

Insurance Companies, Consent to Partial Occupancy

9.9.1

Insured loss, Adjustment and Settlement of

11.5

Intent of the Contract Documents

1.2.1, 4.2.7, 4.2.12, 4.2.13

## **Interest**

### **13.5**

#### **Interpretation**

1.1.8, 1.2.3, **1.4**, 4.1.1, 5.1, 6.1.2, 15.1.1

Interpretations, Written

4.2.11, 4.2.12

Judgment on Final Award

15.4.2

#### **Labor and Materials, Equipment**

1.1.3, 1.1.6, **3.4**, 3.5, 3.8.2, 3.8.3, 3.12, 3.13, 3.15.1,

5.2.1, 6.2.1, 7.3.4, 9.3.2, 9.3.3, 9.5.1.3, 9.10.2, 10.2.1,

10.2.4, 14.2.1.1, 14.2.1.2

Labor Disputes

8.3.1

Laws and Regulations

1.5, 2.3.2, 3.2.3, 3.2.4, 3.6, 3.7, 3.12.10, 3.13, 9.6.4,

9.9.1, 10.2.2, 13.1, 13.3.1, 13.4.2, 13.5, 14, 15.2.8,

15.4

Liens

2.1.2, 9.3.1, 9.3.3, 9.6.8, 9.10.2, 9.10.4, 15.2.8

Limitations, Statutes of

12.2.5, 15.1.2, 15.4.1.1

Limitations of Liability

3.2.2, 3.5, 3.12.10, 3.12.10.1, 3.17, 3.18.1, 4.2.6,

4.2.7, 6.2.2, 9.4.2, 9.6.4, 9.6.7, 9.6.8, 10.2.5, 10.3.3,

11.3, 12.2.5, 13.3.1

Limitations of Time

2.1.2, 2.2, 2.5, 3.2.2, 3.10, 3.11, 3.12.5, 3.15.1, 4.2.7,

5.2, 5.3, 5.4.1, 6.2.4, 7.3, 7.4, 8.2, 9.2, 9.3.1, 9.3.3,

9.4.1, 9.5, 9.6, 9.7, 9.8, 9.9, 9.10, 12.2, 13.4, 14, 15,

15.1.2, 15.1.3, 15.1.5

#### **Materials, Hazardous**

10.2.4, **10.3**

Materials, Labor, Equipment and

1.1.3, 1.1.6, 3.4.1, 3.5, 3.8.2, 3.8.3, 3.12, 3.13, 3.15.1,

5.2.1, 6.2.1, 7.3.4, 9.3.2, 9.3.3, 9.5.1.3, 9.10.2,

10.2.1.2, 10.2.4, 14.2.1.1, 14.2.1.2

Means, Methods, Techniques, Sequences and

Procedures of Construction

3.3.1, 3.12.10, 4.2.2, 4.2.7, 9.4.2

Mechanic's Lien

2.1.2, 9.3.1, 9.3.3, 9.6.8, 9.10.2, 9.10.4, 15.2.8

#### **Mediation**

8.3.1, 15.1.3.2, 15.2.1, 15.2.5, 15.2.6, **15.3**, 15.4.1,

15.4.1.1

#### **Minor Changes in the Work**

1.1.1, 3.4.2, 3.12.8, 4.2.8, 7.1, **7.4**

## **MISCELLANEOUS PROVISIONS**

### **13**

#### **Modifications, Definition of**

##### **1.1.1**

Modifications to the Contract

1.1.1, 1.1.2, 2.5, 3.11, 4.1.2, 4.2.1, 5.2.3, 7, 8.3.1, 9.7,

10.3.2

#### **Mutual Responsibility**

##### **6.2**

## **Nonconforming Work, Acceptance of**

9.6.6, 9.9.3, **12.3**

Nonconforming Work, Rejection and Correction of  
2.4, 2.5, 3.5, 4.2.6, 6.2.4, 9.5.1, 9.8.2, 9.9.3, 9.10.4,  
12.2

### **Notice**

**1.6**, 1.6.1, 1.6.2, 2.1.2, 2.2.2., 2.2.3, 2.2.4, 2.5, 3.2.4,  
3.3.1, 3.7.4, 3.7.5, 3.9.2, 3.12.9, 3.12.10, 5.2.1, 7.4,  
8.2.2 9.6.8, 9.7, 9.10.1, 10.2.8, 10.3.2, 11.5, 12.2.2.1,  
13.4.1, 13.4.2, 14.1, 14.2.2, 14.4.2, 15.1.3, 15.1.5,  
15.1.6, 15.4.1

Notice of Cancellation or Expiration of Insurance  
11.1.4, 11.2.3

### **Notice of Claims**

1.6.2, 2.1.2, 3.7.4, 9.6.8, 10.2.8, **15.1.3**, 15.1.5,  
15.1.6, 15.2.8, 15.3.2, 15.4.1

Notice of Testing and Inspections  
13.4.1, 13.4.2

Observations, Contractor's  
3.2, 3.7.4

### **Occupancy**

2.3.1, 9.6.6, 9.8

### **Orders, Written**

1.1.1, 2.4, 3.9.2, 7, 8.2.2, 11.5, 12.1, 12.2.2.1, 13.4.2,  
14.3.1

## **OWNER**

**2**

**Owner**, Definition of

### **2.1.1**

**Owner**, Evidence of Financial Arrangements  
**2.2**, 13.2.2, 14.1.1.4

**Owner**, Information and Services Required of the  
2.1.2, **2.2**, 2.3, 3.2.2, 3.12.10, 6.1.3, 6.1.4, 6.2.5,  
9.3.2, 9.6.1, 9.6.4, 9.9.2, 9.10.3, 10.3.3, 11.2, 13.4.1,  
13.4.2, 14.1.1.4, 14.1.4, 15.1.4

### **Owner's Authority**

1.5, 2.1.1, 2.3.32.4, 2.5, 3.4.2, 3.8.1, 3.12.10, 3.14.2,  
4.1.2, 4.2.4, 4.2.9, 5.2.1, 5.2.4, 5.4.1, 6.1, 6.3, 7.2.1,  
7.3.1, 8.2.2, 8.3.1, 9.3.2, 9.5.1, 9.6.4, 9.9.1, 9.10.2,  
10.3.2, 11.4, 11.5, 12.2.2, 12.3, 13.2.2, 14.3, 14.4,  
15.2.7

### **Owner's Insurance**

**11.2**

Owner's Relationship with Subcontractors

1.1.2, 5.2, 5.3, 5.4, 9.6.4, 9.10.2, 14.2.2

### **Owner's Right to Carry Out the Work**

**2.5**, 14.2.2

### **Owner's Right to Clean Up**

**6.3**

### **Owner's Right to Perform Construction and to Award Separate Contracts**

**6.1**

### **Owner's Right to Stop the Work**

**2.4**

Owner's Right to Suspend the Work

14.3

Owner's Right to Terminate the Contract

14.2, 14.4

## **Ownership and Use of Drawings, Specifications and Other Instruments of Service**

1.1.1, 1.1.6, 1.1.7, **1.5**, 2.3.6, 3.2.2, 3.11, 3.17, 4.2.12,  
5.3

### **Partial Occupancy or Use**

9.6.6, **9.9**

### **Patching, Cutting and**

**3.14**, 6.2.5

### **Patents**

3.17

### **Payment, Applications for**

4.2.5, 7.3.9, 9.2, **9.3**, 9.4, 9.5, 9.6.3, 9.7, 9.8.5, 9.10.1,  
14.2.3, 14.2.4, 14.4.3

### **Payment, Certificates for**

4.2.5, 4.2.9, 9.3.3, **9.4**, 9.5, 9.6.1, 9.6.6, 9.7, 9.10.1,  
9.10.3, 14.1.1.3, 14.2.4

### **Payment, Failure of**

9.5.1.3, **9.7**, 9.10.2, 13.5, 14.1.1.3, 14.2.1.2

### **Payment, Final**

4.2.1, 4.2.9, **9.10**, 12.3, 14.2.4, 14.4.3

### **Payment Bond, Performance Bond and**

7.3.4.4, 9.6.7, 9.10.3, **11.1.2**

### **Payments, Progress**

9.3, **9.6**, 9.8.5, 9.10.3, 14.2.3, 15.1.4

## **PAYMENTS AND COMPLETION**

**9**

Payments to Subcontractors

5.4.2, 9.5.1.3, 9.6.2, 9.6.3, 9.6.4, 9.6.7, 14.2.1.2

### **PCB**

10.3.1

### **Performance Bond and Payment Bond**

7.3.4.4, 9.6.7, 9.10.3, **11.1.2**

### **Permits, Fees, Notices and Compliance with Laws**

2.3.1, **3.7**, 3.13, 7.3.4.4, 10.2.2

## **PERSONS AND PROPERTY, PROTECTION**

### **OF**

**10**

Polychlorinated Biphenyl

10.3.1

**Product Data**, Definition of

**3.12.2**

**Product Data and Samples, Shop Drawings**

3.11, **3.12**, 4.2.7

### **Progress and Completion**

4.2.2, **8.2**, 9.8, 9.9.1, 14.1.4, 15.1.4

### **Progress Payments**

9.3, **9.6**, 9.8.5, 9.10.3, 14.2.3, 15.1.4

**Project**, Definition of

**1.1.4**

Project Representatives

4.2.10

### **Property Insurance**

10.2.5, **11.2**

### **Proposal Requirements**

1.1.1

## **PROTECTION OF PERSONS AND PROPERTY**

**10**

## Regulations and Laws

1.5, 2.3.2, 3.2.3, 3.6, 3.7, 3.12.10, 3.13, 9.6.4, 9.9.1, 10.2.2, 13.1, 13.3, 13.4.1, 13.4.2, 13.5, 14, 15.2.8, 15.4

## Rejection of Work

4.2.6, 12.2.1

## Releases and Waivers of Liens

9.3.1, 9.10.2

## Representations

3.2.1, 3.5, 3.12.6, 8.2.1, 9.3.3, 9.4.2, 9.5.1, 9.10.1

## Representatives

2.1.1, 3.1.1, 3.9, 4.1.1, 4.2.10, 13.2.1

## Responsibility for Those Performing the Work

3.3.2, 3.18, 4.2.2, 4.2.3, 5.3, 6.1.3, 6.2, 6.3, 9.5.1, 10

## Retainage

9.3.1, 9.6.2, 9.8.5, 9.9.1, 9.10.2, 9.10.3

## Review of Contract Documents and Field

### Conditions by Contractor

3.2, 3.12.7, 6.1.3

### Review of Contractor's Submittals by Owner and Architect

3.10.1, 3.10.2, 3.11, 3.12, 4.2, 5.2, 6.1.3, 9.2, 9.8.2

### Review of Shop Drawings, Product Data and Samples by Contractor

3.12

## Rights and Remedies

1.1.2, 2.4, 2.5, 3.5, 3.7.4, 3.15.2, 4.2.6, 5.3, 5.4, 6.1, 6.3, 7.3.1, 8.3, 9.5.1, 9.7, 10.2.5, 10.3, 12.2.1, 12.2.2, 12.2.4, 13.3, 14, 15.4

## Royalties, Patents and Copyrights

3.17

## Rules and Notices for Arbitration

15.4.1

## Safety of Persons and Property

10.2, 10.4

## Safety Precautions and Programs

3.3.1, 4.2.2, 4.2.7, 5.3, 10.1, 10.2, 10.4

## Samples, Definition of

3.12.3

## Samples, Shop Drawings, Product Data and

3.11, 3.12, 4.2.7

## Samples at the Site, Documents and

3.11

## Schedule of Values

9.2, 9.3.1

## Schedules, Construction

3.10, 3.12.1, 3.12.2, 6.1.3, 15.1.6.2

## Separate Contracts and Contractors

1.1.4, 3.12.5, 3.14.2, 4.2.4, 4.2.7, 6, 8.3.1, 12.1.2

## Separate Contractors, Definition of

6.1.1

## Shop Drawings, Definition of

3.12.1

## Shop Drawings, Product Data and Samples

3.11, 3.12, 4.2.7

## Site, Use of

3.13, 6.1.1, 6.2.1

## Site Inspections

3.2.2, 3.3.3, 3.7.1, 3.7.4, 4.2, 9.9.2, 9.4.2, 9.10.1, 13.4

## Site Visits, Architect's

3.7.4, 4.2.2, 4.2.9, 9.4.2, 9.5.1, 9.9.2, 9.10.1, 13.4

## Special Inspections and Testing

4.2.6, 12.2.1, 13.4

## Specifications, Definition of

1.1.6

## Specifications

1.1.1, 1.1.6, 1.2.2, 1.5, 3.12.10, 3.17, 4.2.14

## Statute of Limitations

15.1.2, 15.4.1.1

## Stopping the Work

2.2.2, 2.4, 9.7, 10.3, 14.1

## Stored Materials

6.2.1, 9.3.2, 10.2.1.2, 10.2.4

## Subcontractor, Definition of

5.1.1

## SUBCONTRACTORS

5

### Subcontractors, Work by

1.2.2, 3.3.2, 3.12.1, 3.18, 4.2.3, 5.2.3, 5.3, 5.4, 9.3.1.2, 9.6.7

### Subcontractual Relations

5.3, 5.4, 9.3.1.2, 9.6, 9.10, 10.2.1, 14.1, 14.2.1

### Submittals

3.10, 3.11, 3.12, 4.2.7, 5.2.1, 5.2.3, 7.3.4, 9.2, 9.3, 9.8, 9.9.1, 9.10.2, 9.10.3

### Submittal Schedule

3.10.2, 3.12.5, 4.2.7

### Subrogation, Waivers of

6.1.1, 11.3

### Substances, Hazardous

10.3

### Substantial Completion

4.2.9, 8.1.1, 8.1.3, 8.2.3, 9.4.2, 9.8, 9.9.1, 9.10.3, 12.2, 15.1.2

### Substantial Completion, Definition of

9.8.1

### Substitution of Subcontractors

5.2.3, 5.2.4

### Substitution of Architect

2.3.3

### Substitutions of Materials

3.4.2, 3.5, 7.3.8

### Sub-subcontractor, Definition of

5.1.2

### Subsurface Conditions

3.7.4

### Successors and Assigns

13.2

### Superintendent

3.9, 10.2.6

### Supervision and Construction Procedures

1.2.2, 3.3, 3.4, 3.12.10, 4.2.2, 4.2.7, 6.1.3, 6.2.4, 7.1.3, 7.3.4, 8.2, 8.3.1, 9.4.2, 10, 12, 14, 15.1.4



Suppliers  
1.5, 3.12.1, 4.2.4, 4.2.6, 5.2.1, 9.3, 9.4.2, 9.5.4, 9.6, 9.10.5, 14.2.1

Surety  
5.4.1.2, 9.6.8, 9.8.5, 9.10.2, 9.10.3, 11.1.2, 14.2.2, 15.2.7

Surety, Consent of  
9.8.5, 9.10.2, 9.10.3

Surveys  
1.1.7, 2.3.4

### **Suspension by the Owner for Convenience** **14.3**

Suspension of the Work  
3.7.5, 5.4.2, 14.3

Suspension or Termination of the Contract  
5.4.1.1, 14

**Taxes**  
3.6, 3.8.2.1, 7.3.4.4

**Termination by the Contractor**  
**14.1**, 15.1.7

**Termination by the Owner for Cause**  
5.4.1.1, **14.2**, 15.1.7

**Termination by the Owner for Convenience**  
**14.4**

Termination of the Architect  
2.3.3

Termination of the Contractor Employment  
14.2.2

## **TERMINATION OR SUSPENSION OF THE CONTRACT**

### **14**

**Tests and Inspections**  
3.1.3, 3.3.3, 3.7.1, 4.2.2, 4.2.6, 4.2.9, 9.4.2, 9.8.3, 9.9.2, 9.10.1, 10.3.2, 12.2.1, **13.4**

### **TIME**

#### **8**

**Time, Delays and Extensions of**  
3.2.4, 3.7.4, 5.2.3, 7.2.1, 7.3.1, 7.4, **8.3**, 9.5.1, 9.7, 10.3.2, 10.4, 14.3.2, 15.1.6, 15.2.5

Time Limits  
2.1.2, 2.2, 2.5, 3.2.2, 3.10, 3.11, 3.12.5, 3.15.1, 4.2, 5.2, 5.3, 5.4, 6.2.4, 7.3, 7.4, 8.2, 9.2, 9.3.1, 9.3.3, 9.4.1, 9.5, 9.6, 9.7, 9.8, 9.9, 9.10, 12.2, 13.4, 14, 15.1.2, 15.1.3, 15.4

### **Time Limits on Claims**

3.7.4, 10.2.8, 15.1.2, 15.1.3

Title to Work

9.3.2, 9.3.3

## **UNCOVERING AND CORRECTION OF WORK**

### **12**

#### **Uncovering of Work**

##### **12.1**

Unforeseen Conditions, Concealed or Unknown  
3.7.4, 8.3.1, 10.3

Unit Prices  
7.3.3.2, 9.1.2

Use of Documents  
1.1.1, 1.5, 2.3.6, 3.12.6, 5.3

#### **Use of Site**

**3.13**, 6.1.1, 6.2.1

#### **Values, Schedule of**

**9.2**, 9.3.1

Waiver of Claims by the Architect  
13.3.2

Waiver of Claims by the Contractor  
9.10.5, 13.3.2, **15.1.7**

Waiver of Claims by the Owner  
9.9.3, 9.10.3, 9.10.4, 12.2.2.1, 13.3.2, 14.2.4, **15.1.7**

Waiver of Consequential Damages  
14.2.4, 15.1.7

Waiver of Liens  
9.3, 9.10.2, 9.10.4

#### **Waivers of Subrogation**

6.1.1, **11.3**

#### **Warranty**

**3.5**, 4.2.9, 9.3.3, 9.8.4, 9.9.1, 9.10.2, 9.10.4, 12.2.2, 15.1.2

Weather Delays  
8.3, 15.1.6.2

#### **Work, Definition of**

**1.1.3**

Written Consent  
1.5.2, 3.4.2, 3.7.4, 3.12.8, 3.14.2, 4.1.2, 9.3.2, 9.10.3, 13.2, 13.3.2, 15.4.4.2

Written Interpretations

4.2.11, 4.2.12

Written Orders

1.1.1, 2.4, 3.9, 7, 8.2.2, 12.1, 12.2, 13.4.2, 14.3.1

## ARTICLE 1 GENERAL PROVISIONS

### § 1.1 Basic Definitions

#### § 1.1.1 The Contract Documents

The Contract Documents are enumerated in the Agreement between the Owner and Contractor (hereinafter the Agreement) and consist of the Agreement, Conditions of the Contract (General, Supplementary and other Conditions), Drawings, Specifications, Addenda issued prior to execution of the Contract, other documents listed in the Agreement, and Modifications issued after execution of the Contract. A Modification is (1) a written amendment to the Contract signed by both parties, (2) a Change Order, (3) a Construction Change Directive, or (4) a written order for a minor change in the Work issued by the Architect. Unless specifically enumerated in the Agreement, the Contract Documents do not include the advertisement or invitation to bid, Instructions to Bidders, sample forms, other information furnished by the Owner in anticipation of receiving bids or proposals, the Contractor's bid or proposal, or portions of Addenda relating to bidding or proposal requirements.

#### § 1.1.2 The Contract

The Contract Documents form the Contract for Construction. The Contract represents the entire and integrated agreement between the parties hereto and supersedes prior negotiations, representations, or agreements, either written or oral. The Contract may be amended or modified only by a Modification. The Contract Documents shall not be construed to create a contractual relationship of any kind (1) between the Contractor and the Architect or the Architect's consultants, (2) between the Owner and a Subcontractor or a Sub-subcontractor, (3) between the Owner and the Architect or the Architect's consultants, or (4) between any persons or entities other than the Owner and the Contractor. The Architect shall, however, be entitled to performance and enforcement of obligations under the Contract intended to facilitate performance of the Architect's duties.

#### § 1.1.3 The Work

The term "Work" means the construction and services required by the Contract Documents, whether completed or partially completed, and includes all other labor, materials, equipment, and services provided or to be provided by the Contractor to fulfill the Contractor's obligations. The Work may constitute the whole or a part of the Project.

#### § 1.1.4 The Project

The Project is the total construction of which the Work performed under the Contract Documents may be the whole or a part and which may include construction by the Owner and by Separate Contractors.

#### § 1.1.5 The Drawings

The Drawings are the graphic and pictorial portions of the Contract Documents showing the design, location and dimensions of the Work, generally including plans, elevations, sections, details, schedules, and diagrams.

#### § 1.1.6 The Specifications

The Specifications are that portion of the Contract Documents consisting of the written requirements for materials, equipment, systems, standards and workmanship for the Work, and performance of related services.

#### § 1.1.7 Instruments of Service

Instruments of Service are representations, in any medium of expression now known or later developed, of the tangible and intangible creative work performed by the Architect and the Architect's consultants under their respective professional services agreements. Instruments of Service may include, without limitation, studies, surveys, models, sketches, drawings, specifications, and other similar materials.

#### § 1.1.8 Initial Decision Maker

The Initial Decision Maker is the person identified in the Agreement to render initial decisions on Claims in accordance with Section 15.2. The Initial Decision Maker shall not show partiality to the Owner or Contractor and shall not be liable for results of interpretations or decisions rendered in good faith.

### § 1.2 Correlation and Intent of the Contract Documents

§ 1.2.1 The intent of the Contract Documents is to include all items necessary for the proper execution and completion of the Work by the Contractor. The Contract Documents are complementary, and what is required by one shall be as binding as if required by all; performance by the Contractor shall be required only to the extent consistent with the Contract Documents and reasonably inferable from them as being necessary to produce the indicated results.

§ 1.2.1.1 The invalidity of any provision of the Contract Documents shall not invalidate the Contract or its remaining provisions. If it is determined that any provision of the Contract Documents violates any law, or is otherwise invalid or unenforceable, then that provision shall be revised to the extent necessary to make that provision legal and enforceable. In such case the Contract Documents shall be construed, to the fullest extent permitted by law, to give effect to the parties' intentions and purposes in executing the Contract.

§ 1.2.2 Organization of the Specifications into divisions, sections and articles, and arrangement of Drawings shall not control the Contractor in dividing the Work among Subcontractors or in establishing the extent of Work to be performed by any trade.

§ 1.2.3 Unless otherwise stated in the Contract Documents, words that have well-known technical or construction industry meanings are used in the Contract Documents in accordance with such recognized meanings.

### § 1.3 Capitalization

Terms capitalized in these General Conditions include those that are (1) specifically defined, (2) the titles of numbered articles, or (3) the titles of other documents published by the American Institute of Architects.

### § 1.4 Interpretation

In the interest of brevity the Contract Documents frequently omit modifying words such as "all" and "any" and articles such as "the" and "an," but the fact that a modifier or an article is absent from one statement and appears in another is not intended to affect the interpretation of either statement.

### § 1.5 Ownership and Use of Drawings, Specifications, and Other Instruments of Service

§ 1.5.1 The Architect and the Architect's consultants shall be deemed the authors and owners of their respective Instruments of Service, including the Drawings and Specifications, and retain all common law, statutory, and other reserved rights in their Instruments of Service, including copyrights. The Contractor, Subcontractors, Sub-subcontractors, and suppliers shall not own or claim a copyright in the Instruments of Service. Submittal or distribution to meet official regulatory requirements or for other purposes in connection with the Project is not to be construed as publication in derogation of the Architect's or Architect's consultants' reserved rights.

§ 1.5.2 The Contractor, Subcontractors, Sub-subcontractors, and suppliers are authorized to use and reproduce the Instruments of Service provided to them, subject to any protocols established pursuant to Sections 1.7 and 1.8, solely and exclusively for execution of the Work. All copies made under this authorization shall bear the copyright notice, if any, shown on the Instruments of Service. The Contractor, Subcontractors, Sub-subcontractors, and suppliers may not use the Instruments of Service on other projects or for additions to the Project outside the scope of the Work without the specific written consent of the Owner, Architect, and the Architect's consultants.

### § 1.6 Notice

§ 1.6.1 Except as otherwise provided in Section 1.6.2, where the Contract Documents require one party to notify or give notice to the other party, such notice shall be provided in writing to the designated representative of the party to whom the notice is addressed and shall be deemed to have been duly served if delivered in person, by mail, by courier, or by electronic transmission if a method for electronic transmission is set forth in the Agreement.

§ 1.6.2 Notice of Claims as provided in Section 15.1.3 shall be provided in writing and shall be deemed to have been duly served only if delivered to the designated representative of the party to whom the notice is addressed by certified or registered mail, or by courier providing proof of delivery.

### § 1.7 Digital Data Use and Transmission

The parties shall agree upon protocols governing the transmission and use of Instruments of Service or any other information or documentation in digital form. The parties will use AIA Document E203™–2013, Building Information Modeling and Digital Data Exhibit, to establish the protocols for the development, use, transmission, and exchange of digital data.

### § 1.8 Building Information Models Use and Reliance

Any use of, or reliance on, all or a portion of a building information model without agreement to protocols governing the use of, and reliance on, the information contained in the model and without having those protocols set forth in AIA Document E203™–2013, Building Information Modeling and Digital Data Exhibit, and the requisite AIA Document G202™–2013, Project Building Information Modeling Protocol Form, shall be at the using or

relying party's sole risk and without liability to the other party and its contractors or consultants, the authors of, or contributors to, the building information model, and each of their agents and employees.

## ARTICLE 2 OWNER

### § 2.1 General

§ 2.1.1 The Owner is the person or entity identified as such in the Agreement and is referred to throughout the Contract Documents as if singular in number. The Owner shall designate in writing a representative who shall have express authority to bind the Owner with respect to all matters requiring the Owner's approval or authorization. Except as otherwise provided in Section 4.2.1, the Architect does not have such authority. The term "Owner" means the Owner or the Owner's authorized representative.

§ 2.1.2 The Owner shall furnish to the Contractor, within fifteen days after receipt of a written request, information necessary and relevant for the Contractor to evaluate, give notice of, or enforce mechanic's lien rights. Such information shall include a correct statement of the record legal title to the property on which the Project is located, usually referred to as the site, and the Owner's interest therein.

### § 2.2 Evidence of the Owner's Financial Arrangements

§ 2.2.1 Prior to commencement of the Work and upon written request by the Contractor, the Owner shall furnish to the Contractor reasonable evidence that the Owner has made financial arrangements to fulfill the Owner's obligations under the Contract. The Contractor shall have no obligation to commence the Work until the Owner provides such evidence. If commencement of the Work is delayed under this Section 2.2.1, the Contract Time shall be extended appropriately.

§ 2.2.2 Following commencement of the Work and upon written request by the Contractor, the Owner shall furnish to the Contractor reasonable evidence that the Owner has made financial arrangements to fulfill the Owner's obligations under the Contract only if (1) the Owner fails to make payments to the Contractor as the Contract Documents require; (2) the Contractor identifies in writing a reasonable concern regarding the Owner's ability to make payment when due; or (3) a change in the Work materially changes the Contract Sum. If the Owner fails to provide such evidence, as required, within fourteen days of the Contractor's request, the Contractor may immediately stop the Work and, in that event, shall notify the Owner that the Work has stopped. However, if the request is made because a change in the Work materially changes the Contract Sum under (3) above, the Contractor may immediately stop only that portion of the Work affected by the change until reasonable evidence is provided. If the Work is stopped under this Section 2.2.2, the Contract Time shall be extended appropriately and the Contract Sum shall be increased by the amount of the Contractor's reasonable costs of shutdown, delay and start-up, plus interest as provided in the Contract Documents.

§ 2.2.3 After the Owner furnishes evidence of financial arrangements under this Section 2.2, the Owner shall not materially vary such financial arrangements without prior notice to the Contractor.

§ 2.2.4 Where the Owner has designated information furnished under this Section 2.2 as "confidential," the Contractor shall keep the information confidential and shall not disclose it to any other person. However, the Contractor may disclose "confidential" information, after seven (7) days' notice to the Owner, where disclosure is required by law, including a subpoena or other form of compulsory legal process issued by a court or governmental entity, or by court or arbitrator(s) order. The Contractor may also disclose "confidential" information to its employees, consultants, sureties, Subcontractors and their employees, Sub-subcontractors, and others who need to know the content of such information solely and exclusively for the Project and who agree to maintain the confidentiality of such information.

### § 2.3 Information and Services Required of the Owner

§ 2.3.1 Except for permits and fees that are the responsibility of the Contractor under the Contract Documents, including those required under Section 3.7.1, the Owner shall secure and pay for necessary approvals, easements, assessments and charges required for construction, use or occupancy of permanent structures or for permanent changes in existing facilities.

§ 2.3.2 The Owner shall retain an architect lawfully licensed to practice architecture, or an entity lawfully practicing architecture, in the jurisdiction where the Project is located. That person or entity is identified as the Architect in the Agreement and is referred to throughout the Contract Documents as if singular in number.

§ 2.3.3 If the employment of the Architect terminates, the Owner shall employ a successor to whom the Contractor has no reasonable objection and whose status under the Contract Documents shall be that of the Architect.

§ 2.3.4 The Owner shall furnish surveys describing physical characteristics, legal limitations and utility locations for the site of the Project, and a legal description of the site. The Contractor shall be entitled to rely on the accuracy of information furnished by the Owner but shall exercise proper precautions relating to the safe performance of the Work.

§ 2.3.5 The Owner shall furnish information or services required of the Owner by the Contract Documents with reasonable promptness. The Owner shall also furnish any other information or services under the Owner's control and relevant to the Contractor's performance of the Work with reasonable promptness after receiving the Contractor's written request for such information or services.

§ 2.3.6 Unless otherwise provided in the Contract Documents, the Owner shall furnish to the Contractor one copy of the Contract Documents for purposes of making reproductions pursuant to Section 1.5.2.

#### § 2.4 Owner's Right to Stop the Work

If the Contractor fails to correct Work that is not in accordance with the requirements of the Contract Documents as required by Section 12.2 or repeatedly fails to carry out Work in accordance with the Contract Documents, the Owner may issue a written order to the Contractor to stop the Work, or any portion thereof, until the cause for such order has been eliminated; however, the right of the Owner to stop the Work shall not give rise to a duty on the part of the Owner to exercise this right for the benefit of the Contractor or any other person or entity, except to the extent required by Section 6.1.3.

#### § 2.5 Owner's Right to Carry Out the Work

If the Contractor defaults or neglects to carry out the Work in accordance with the Contract Documents and fails within a ten-day period after receipt of notice from the Owner to commence and continue correction of such default or neglect with diligence and promptness, the Owner may, without prejudice to other remedies the Owner may have, correct such default or neglect. Such action by the Owner and amounts charged to the Contractor are both subject to prior approval of the Architect and the Architect may, pursuant to Section 9.5.1, withhold or nullify a Certificate for Payment in whole or in part, to the extent reasonably necessary to reimburse the Owner for the reasonable cost of correcting such deficiencies, including Owner's expenses and compensation for the Architect's additional services made necessary by such default, neglect, or failure. If current and future payments are not sufficient to cover such amounts, the Contractor shall pay the difference to the Owner. If the Contractor disagrees with the actions of the Owner or the Architect, or the amounts claimed as costs to the Owner, the Contractor may file a Claim pursuant to Article 15.

### ARTICLE 3 CONTRACTOR

#### § 3.1 General

§ 3.1.1 The Contractor is the person or entity identified as such in the Agreement and is referred to throughout the Contract Documents as if singular in number. The Contractor shall be lawfully licensed, if required in the jurisdiction where the Project is located. The Contractor shall designate in writing a representative who shall have express authority to bind the Contractor with respect to all matters under this Contract. The term "Contractor" means the Contractor or the Contractor's authorized representative.

§ 3.1.2 The Contractor shall perform the Work in accordance with the Contract Documents.

§ 3.1.3 The Contractor shall not be relieved of its obligations to perform the Work in accordance with the Contract Documents either by activities or duties of the Architect in the Architect's administration of the Contract, or by tests, inspections or approvals required or performed by persons or entities other than the Contractor.

#### § 3.2 Review of Contract Documents and Field Conditions by Contractor

§ 3.2.1 Execution of the Contract by the Contractor is a representation that the Contractor has visited the site, become generally familiar with local conditions under which the Work is to be performed, and correlated personal observations with requirements of the Contract Documents.

§ 3.2.2 Because the Contract Documents are complementary, the Contractor shall, before starting each portion of the Work, carefully study and compare the various Contract Documents relative to that portion of the Work, as well as



the information furnished by the Owner pursuant to Section 2.3.4, shall take field measurements of any existing conditions related to that portion of the Work, and shall observe any conditions at the site affecting it. These obligations are for the purpose of facilitating coordination and construction by the Contractor and are not for the purpose of discovering errors, omissions, or inconsistencies in the Contract Documents; however, the Contractor shall promptly report to the Architect any errors, inconsistencies or omissions discovered by or made known to the Contractor as a request for information in such form as the Architect may require. It is recognized that the Contractor's review is made in the Contractor's capacity as a contractor and not as a licensed design professional, unless otherwise specifically provided in the Contract Documents.

§ 3.2.3 The Contractor is not required to ascertain that the Contract Documents are in accordance with applicable laws, statutes, ordinances, codes, rules and regulations, or lawful orders of public authorities, but the Contractor shall promptly report to the Architect any nonconformity discovered by or made known to the Contractor as a request for information in such form as the Architect may require.

§ 3.2.4 If the Contractor believes that additional cost or time is involved because of clarifications or instructions the Architect issues in response to the Contractor's notices or requests for information pursuant to Sections 3.2.2 or 3.2.3, the Contractor shall submit Claims as provided in Article 15. If the Contractor fails to perform the obligations of Sections 3.2.2 or 3.2.3, the Contractor shall pay such costs and damages to the Owner, subject to Section 15.1.7, as would have been avoided if the Contractor had performed such obligations. If the Contractor performs those obligations, the Contractor shall not be liable to the Owner or Architect for damages resulting from errors, inconsistencies or omissions in the Contract Documents, for differences between field measurements or conditions and the Contract Documents, or for nonconformities of the Contract Documents to applicable laws, statutes, ordinances, codes, rules and regulations, and lawful orders of public authorities.

### § 3.3 Supervision and Construction Procedures

§ 3.3.1 The Contractor shall supervise and direct the Work, using the Contractor's best skill and attention. The Contractor shall be solely responsible for, and have control over, construction means, methods, techniques, sequences, and procedures, and for coordinating all portions of the Work under the Contract. If the Contract Documents give specific instructions concerning construction means, methods, techniques, sequences, or procedures, the Contractor shall evaluate the jobsite safety thereof and shall be solely responsible for the jobsite safety of such means, methods, techniques, sequences, or procedures. If the Contractor determines that such means, methods, techniques, sequences or procedures may not be safe, the Contractor shall give timely notice to the Owner and Architect, and shall propose alternative means, methods, techniques, sequences, or procedures. The Architect shall evaluate the proposed alternative solely for conformance with the design intent for the completed construction. Unless the Architect objects to the Contractor's proposed alternative, the Contractor shall perform the Work using its alternative means, methods, techniques, sequences, or procedures.

§ 3.3.2 The Contractor shall be responsible to the Owner for acts and omissions of the Contractor's employees, Subcontractors and their agents and employees, and other persons or entities performing portions of the Work for, or on behalf of, the Contractor or any of its Subcontractors.

§ 3.3.3 The Contractor shall be responsible for inspection of portions of Work already performed to determine that such portions are in proper condition to receive subsequent Work.

### § 3.4 Labor and Materials

§ 3.4.1 Unless otherwise provided in the Contract Documents, the Contractor shall provide and pay for labor, materials, equipment, tools, construction equipment and machinery, water, heat, utilities, transportation, and other facilities and services necessary for proper execution and completion of the Work, whether temporary or permanent and whether or not incorporated or to be incorporated in the Work.

§ 3.4.2 Except in the case of minor changes in the Work approved by the Architect in accordance with Section 3.12.8 or ordered by the Architect in accordance with Section 7.4, the Contractor may make substitutions only with the consent of the Owner, after evaluation by the Architect and in accordance with a Change Order or Construction Change Directive.

§ 3.4.3 The Contractor shall enforce strict discipline and good order among the Contractor's employees and other persons carrying out the Work. The Contractor shall not permit employment of unfit persons or persons not properly skilled in tasks assigned to them.



### § 3.5 Warranty

§ 3.5.1 The Contractor warrants to the Owner and Architect that materials and equipment furnished under the Contract will be of good quality and new unless the Contract Documents require or permit otherwise. The Contractor further warrants that the Work will conform to the requirements of the Contract Documents and will be free from defects, except for those inherent in the quality of the Work the Contract Documents require or permit. Work, materials, or equipment not conforming to these requirements may be considered defective. The Contractor's warranty excludes remedy for damage or defect caused by abuse, alterations to the Work not executed by the Contractor, improper or insufficient maintenance, improper operation, or normal wear and tear and normal usage. If required by the Architect, the Contractor shall furnish satisfactory evidence as to the kind and quality of materials and equipment.

§ 3.5.2 All material, equipment, or other special warranties required by the Contract Documents shall be issued in the name of the Owner, or shall be transferable to the Owner, and shall commence in accordance with Section 9.8.4.

### § 3.6 Taxes

The Contractor shall pay sales, consumer, use and similar taxes for the Work provided by the Contractor that are legally enacted when bids are received or negotiations concluded, whether or not yet effective or merely scheduled to go into effect.

The City of Evansville is exempt from Wisconsin State sales and use taxes on materials and equipment to be incorporated in the Work; said taxes shall not be included in the Bid.

### § 3.7 Permits, Fees, Notices and Compliance with Laws

§ 3.7.1 Unless otherwise provided in the Contract Documents, the Contractor shall secure and pay for the building permit as well as for other permits, fees, licenses, and inspections by government agencies necessary for proper execution and completion of the Work that are customarily secured after execution of the Contract and legally required at the time bids are received or negotiations concluded.

§ 3.7.2 The Contractor shall comply with and give notices required by applicable laws, statutes, ordinances, codes, rules and regulations, and lawful orders of public authorities applicable to performance of the Work.

§ 3.7.3 If the Contractor performs Work knowing it to be contrary to applicable laws, statutes, ordinances, codes, rules and regulations, or lawful orders of public authorities, the Contractor shall assume appropriate responsibility for such Work and shall bear the costs attributable to correction.

### § 3.7.4 Concealed or Unknown Conditions

If the Contractor encounters conditions at the site that are (1) subsurface or otherwise concealed physical conditions that differ materially from those indicated in the Contract Documents or (2) unknown physical conditions of an unusual nature that differ materially from those ordinarily found to exist and generally recognized as inherent in construction activities of the character provided for in the Contract Documents, the Contractor shall promptly provide notice to the Owner and the Architect before conditions are disturbed and in no event later than 14 days after first observance of the conditions. The Architect will promptly investigate such conditions and, if the Architect determines that they differ materially and cause an increase or decrease in the Contractor's cost of, or time required for, performance of any part of the Work, will recommend that an equitable adjustment be made in the Contract Sum or Contract Time, or both. If the Architect determines that the conditions at the site are not materially different from those indicated in the Contract Documents and that no change in the terms of the Contract is justified, the Architect shall promptly notify the Owner and Contractor, stating the reasons. If either party disputes the Architect's determination or recommendation, that party may submit a Claim as provided in Article 15.

§ 3.7.5 If, in the course of the Work, the Contractor encounters human remains or recognizes the existence of burial markers, archaeological sites or wetlands not indicated in the Contract Documents, the Contractor shall immediately suspend any operations that would affect them and shall notify the Owner and Architect. Upon receipt of such notice, the Owner shall promptly take any action necessary to obtain governmental authorization required to resume the operations. The Contractor shall continue to suspend such operations until otherwise instructed by the Owner but shall continue with all other operations that do not affect those remains or features. Requests for adjustments in the Contract Sum and Contract Time arising from the existence of such remains or features may be made as provided in Article 15.

## § 3.8 Allowances

§ 3.8.1 The Contractor shall include in the Contract Sum all allowances stated in the Contract Documents. Items covered by allowances shall be supplied for such amounts and by such persons or entities as the Owner may direct, but the Contractor shall not be required to employ persons or entities to whom the Contractor has reasonable objection.

§ 3.8.2 Unless otherwise provided in the Contract Documents,

- .1 allowances shall cover the cost to the Contractor of materials and equipment delivered at the site and all required taxes, less applicable trade discounts;
- .2 Contractor's costs for unloading and handling at the site, labor, installation costs, overhead, profit, and other expenses contemplated for stated allowance amounts shall be included in the Contract Sum but not in the allowances; and
- .3 whenever costs are more than or less than allowances, the Contract Sum shall be adjusted accordingly by Change Order. The amount of the Change Order shall reflect (1) the difference between actual costs and the allowances under Section 3.8.2.1 and (2) changes in Contractor's costs under Section 3.8.2.2.

§ 3.8.3 Materials and equipment under an allowance shall be selected by the Owner with reasonable promptness.

## § 3.9 Superintendent

§ 3.9.1 The Contractor shall employ a competent superintendent and necessary assistants who shall be in attendance at the Project site during performance of the Work. The superintendent shall represent the Contractor, and communications given to the superintendent shall be as binding as if given to the Contractor.

§ 3.9.2 The Contractor, as soon as practicable after award of the Contract, shall notify the Owner and Architect of the name and qualifications of a proposed superintendent. Within 14 days of receipt of the information, the Architect may notify the Contractor, stating whether the Owner or the Architect (1) has reasonable objection to the proposed superintendent or (2) requires additional time for review. Failure of the Architect to provide notice within the 14-day period shall constitute notice of no reasonable objection.

§ 3.9.3 The Contractor shall not employ a proposed superintendent to whom the Owner or Architect has made reasonable and timely objection. The Contractor shall not change the superintendent without the Owner's consent, which shall not unreasonably be withheld or delayed.

## § 3.10 Contractor's Construction and Submittal Schedules

§ 3.10.1 The Contractor, promptly after being awarded the Contract, shall submit for the Owner's and Architect's information a Contractor's construction schedule for the Work. The schedule shall contain detail appropriate for the Project, including (1) the date of commencement of the Work, interim schedule milestone dates, and the date of Substantial Completion; (2) an apportionment of the Work by construction activity; and (3) the time required for completion of each portion of the Work. The schedule shall provide for the orderly progression of the Work to completion and shall not exceed time limits current under the Contract Documents. The schedule shall be revised at appropriate intervals as required by the conditions of the Work and Project.

§ 3.10.2 The Contractor, promptly after being awarded the Contract and thereafter as necessary to maintain a current submittal schedule, shall submit a submittal schedule for the Architect's approval. The Architect's approval shall not be unreasonably delayed or withheld. The submittal schedule shall (1) be coordinated with the Contractor's construction schedule, and (2) allow the Architect reasonable time to review submittals. If the Contractor fails to submit a submittal schedule, or fails to provide submittals in accordance with the approved submittal schedule, the Contractor shall not be entitled to any increase in Contract Sum or extension of Contract Time based on the time required for review of submittals.

§ 3.10.3 The Contractor shall perform the Work in general accordance with the most recent schedules submitted to the Owner and Architect.

## § 3.11 Documents and Samples at the Site

The Contractor shall make available, at the Project site, the Contract Documents, including Change Orders, Construction Change Directives, and other Modifications, in good order and marked currently to indicate field

changes and selections made during construction, and the approved Shop Drawings, Product Data, Samples, and similar required submittals. These shall be in electronic form or paper copy, available to the Architect and Owner, and delivered to the Architect for submittal to the Owner upon completion of the Work as a record of the Work as constructed.

§ 3.12 Shop Drawings, Product Data and Samples

§ 3.12.1 Shop Drawings are drawings, diagrams, schedules, and other data specially prepared for the Work by the Contractor or a Subcontractor, Sub-subcontractor, manufacturer, supplier, or distributor to illustrate some portion of the Work.

§ 3.12.2 Product Data are illustrations, standard schedules, performance charts, instructions, brochures, diagrams, and other information furnished by the Contractor to illustrate materials or equipment for some portion of the Work.

§ 3.12.3 Samples are physical examples that illustrate materials, equipment, or workmanship, and establish standards by which the Work will be judged.

§ 3.12.4 Shop Drawings, Product Data, Samples, and similar submittals are not Contract Documents. Their purpose is to demonstrate how the Contractor proposes to conform to the information given and the design concept expressed in the Contract Documents for those portions of the Work for which the Contract Documents require submittals. Review by the Architect is subject to the limitations of Section 4.2.7. Informational submittals upon which the Architect is not expected to take responsive action may be so identified in the Contract Documents. Submittals that are not required by the Contract Documents may be returned by the Architect without action.

§ 3.12.5 The Contractor shall review for compliance with the Contract Documents, approve, and submit to the Architect, Shop Drawings, Product Data, Samples, and similar submittals required by the Contract Documents, in accordance with the submittal schedule approved by the Architect or, in the absence of an approved submittal schedule, with reasonable promptness and in such sequence as to cause no delay in the Work or in the activities of the Owner or of Separate Contractors.

§ 3.12.6 By submitting Shop Drawings, Product Data, Samples, and similar submittals, the Contractor represents to the Owner and Architect that the Contractor has (1) reviewed and approved them, (2) determined and verified materials, field measurements and field construction criteria related thereto, or will do so, and (3) checked and coordinated the information contained within such submittals with the requirements of the Work and of the Contract Documents.

§ 3.12.7 The Contractor shall perform no portion of the Work for which the Contract Documents require submittal and review of Shop Drawings, Product Data, Samples, or similar submittals, until the respective submittal has been approved by the Architect.

§ 3.12.8 The Work shall be in accordance with approved submittals except that the Contractor shall not be relieved of responsibility for deviations from the requirements of the Contract Documents by the Architect's approval of Shop Drawings, Product Data, Samples, or similar submittals, unless the Contractor has specifically notified the Architect of such deviation at the time of submittal and (1) the Architect has given written approval to the specific deviation as a minor change in the Work, or (2) a Change Order or Construction Change Directive has been issued authorizing the deviation. The Contractor shall not be relieved of responsibility for errors or omissions in Shop Drawings, Product Data, Samples, or similar submittals, by the Architect's approval thereof.

§ 3.12.9 The Contractor shall direct specific attention, in writing or on resubmitted Shop Drawings, Product Data, Samples, or similar submittals, to revisions other than those requested by the Architect on previous submittals. In the absence of such notice, the Architect's approval of a resubmission shall not apply to such revisions.

§ 3.12.10 The Contractor shall not be required to provide professional services that constitute the practice of architecture or engineering unless such services are specifically required by the Contract Documents for a portion of the Work or unless the Contractor needs to provide such services in order to carry out the Contractor's responsibilities for construction means, methods, techniques, sequences, and procedures. The Contractor shall not be required to provide professional services in violation of applicable law.

§ 3.12.10.1 If professional design services or certifications by a design professional related to systems, materials, or equipment are specifically required of the Contractor by the Contract Documents, the Owner and the Architect will specify all performance and design criteria that such services must satisfy. The Contractor shall be entitled to rely upon the adequacy and accuracy of the performance and design criteria provided in the Contract Documents. The Contractor shall cause such services or certifications to be provided by an appropriately licensed design professional, whose signature and seal shall appear on all drawings, calculations, specifications, certifications, Shop Drawings, and other submittals prepared by such professional. Shop Drawings, and other submittals related to the Work, designed or certified by such professional, if prepared by others, shall bear such professional's written approval when submitted to the Architect. The Owner and the Architect shall be entitled to rely upon the adequacy and accuracy of the services, certifications, and approvals performed or provided by such design professionals, provided the Owner and Architect have specified to the Contractor the performance and design criteria that such services must satisfy. Pursuant to this Section 3.12.10, the Architect will review and approve or take other appropriate action on submittals only for the limited purpose of checking for conformance with information given and the design concept expressed in the Contract Documents.

§ 3.12.10.2 If the Contract Documents require the Contractor's design professional to certify that the Work has been performed in accordance with the design criteria, the Contractor shall furnish such certifications to the Architect at the time and in the form specified by the Architect.

### § 3.13 Use of Site

The Contractor shall confine operations at the site to areas permitted by applicable laws, statutes, ordinances, codes, rules and regulations, lawful orders of public authorities, and the Contract Documents and shall not unreasonably encumber the site with materials or equipment.

### § 3.14 Cutting and Patching

§ 3.14.1 The Contractor shall be responsible for cutting, fitting, or patching required to complete the Work or to make its parts fit together properly. All areas requiring cutting, fitting, or patching shall be restored to the condition existing prior to the cutting, fitting, or patching, unless otherwise required by the Contract Documents.

§ 3.14.2 The Contractor shall not damage or endanger a portion of the Work or fully or partially completed construction of the Owner or Separate Contractors by cutting, patching, or otherwise altering such construction, or by excavation. The Contractor shall not cut or otherwise alter construction by the Owner or a Separate Contractor except with written consent of the Owner and of the Separate Contractor. Consent shall not be unreasonably withheld. The Contractor shall not unreasonably withhold, from the Owner or a Separate Contractor, its consent to cutting or otherwise altering the Work.

### § 3.15 Cleaning Up

§ 3.15.1 The Contractor shall keep the premises and surrounding area free from accumulation of waste materials and rubbish caused by operations under the Contract. At completion of the Work, the Contractor shall remove waste materials, rubbish, the Contractor's tools, construction equipment, machinery, and surplus materials from and about the Project.

§ 3.15.2 If the Contractor fails to clean up as provided in the Contract Documents, the Owner may do so and the Owner shall be entitled to reimbursement from the Contractor.

### § 3.16 Access to Work

The Contractor shall provide the Owner and Architect with access to the Work in preparation and progress wherever located.

### § 3.17 Royalties, Patents and Copyrights

The Contractor shall pay all royalties and license fees. The Contractor shall defend suits or claims for infringement of copyrights and patent rights and shall hold the Owner and Architect harmless from loss on account thereof, but shall not be responsible for defense or loss when a particular design, process, or product of a particular manufacturer or manufacturers is required by the Contract Documents, or where the copyright violations are contained in Drawings, Specifications, or other documents prepared by the Owner or Architect. However, if an infringement of a copyright or patent is discovered by, or made known to, the Contractor, the Contractor shall be responsible for the loss unless the information is promptly furnished to the Architect.

## § 3.18 Indemnification

§ 3.18.1 To the fullest extent permitted by law, the Contractor shall indemnify and hold harmless the Owner, Architect, Architect's consultants, and agents and employees of any of them from and against claims, damages, losses, and expenses, including but not limited to attorneys' fees, arising out of or resulting from performance of the Work, provided that such claim, damage, loss, or expense is attributable to bodily injury, sickness, disease or death, or to injury to or destruction of tangible property (other than the Work itself), but only to the extent caused by the negligent acts or omissions of the Contractor, a Subcontractor, anyone directly or indirectly employed by them, or anyone for whose acts they may be liable, regardless of whether or not such claim, damage, loss, or expense is caused in part by a party indemnified hereunder. Such obligation shall not be construed to negate, abridge, or reduce other rights or obligations of indemnity that would otherwise exist as to a party or person described in this Section 3.18.

§ 3.18.2 In claims against any person or entity indemnified under this Section 3.18 by an employee of the Contractor, a Subcontractor, anyone directly or indirectly employed by them, or anyone for whose acts they may be liable, the indemnification obligation under Section 3.18.1 shall not be limited by a limitation on amount or type of damages, compensation, or benefits payable by or for the Contractor or a Subcontractor under workers' compensation acts, disability benefit acts, or other employee benefit acts.

## ARTICLE 4 ARCHITECT

### § 4.1 General

§ 4.1.1 The Architect is the person or entity retained by the Owner pursuant to Section 2.3.2 and identified as such in the Agreement.

§ 4.1.2 Duties, responsibilities, and limitations of authority of the Architect as set forth in the Contract Documents shall not be restricted, modified, or extended without written consent of the Owner, Contractor, and Architect. Consent shall not be unreasonably withheld.

### § 4.2 Administration of the Contract

§ 4.2.1 The Architect will provide administration of the Contract as described in the Contract Documents and will be an Owner's representative during construction until the date the Architect issues the final Certificate for Payment. The Architect will have authority to act on behalf of the Owner only to the extent provided in the Contract Documents.

§ 4.2.2 The Architect will visit the site at intervals appropriate to the stage of construction, or as otherwise agreed with the Owner, to become generally familiar with the progress and quality of the portion of the Work completed, and to determine in general if the Work observed is being performed in a manner indicating that the Work, when fully completed, will be in accordance with the Contract Documents. However, the Architect will not be required to make exhaustive or continuous on-site inspections to check the quality or quantity of the Work. The Architect will not have control over, charge of, or responsibility for the construction means, methods, techniques, sequences or procedures, or for the safety precautions and programs in connection with the Work, since these are solely the Contractor's rights and responsibilities under the Contract Documents.

§ 4.2.3 On the basis of the site visits, the Architect will keep the Owner reasonably informed about the progress and quality of the portion of the Work completed, and promptly report to the Owner (1) known deviations from the Contract Documents, (2) known deviations from the most recent construction schedule submitted by the Contractor, and (3) defects and deficiencies observed in the Work. The Architect will not be responsible for the Contractor's failure to perform the Work in accordance with the requirements of the Contract Documents. The Architect will not have control over or charge of, and will not be responsible for acts or omissions of, the Contractor, Subcontractors, or their agents or employees, or any other persons or entities performing portions of the Work.

### § 4.2.4 Communications

The Owner and Contractor shall include the Architect in all communications that relate to or affect the Architect's services or professional responsibilities. The Owner shall promptly notify the Architect of the substance of any direct communications between the Owner and the Contractor otherwise relating to the Project. Communications by and with the Architect's consultants shall be through the Architect. Communications by and with Subcontractors and suppliers shall be through the Contractor. Communications by and with Separate Contractors shall be through the Owner. The Contract Documents may specify other communication protocols.



§ 4.2.5 Based on the Architect's evaluations of the Contractor's Applications for Payment, the Architect will review and certify the amounts due the Contractor and will issue Certificates for Payment in such amounts.

§ 4.2.6 The Architect has authority to reject Work that does not conform to the Contract Documents. Whenever the Architect considers it necessary or advisable, the Architect will have authority to require inspection or testing of the Work in accordance with Sections 13.4.2 and 13.4.3, whether or not the Work is fabricated, installed or completed. However, neither this authority of the Architect nor a decision made in good faith either to exercise or not to exercise such authority shall give rise to a duty or responsibility of the Architect to the Contractor, Subcontractors, suppliers, their agents or employees, or other persons or entities performing portions of the Work.

§ 4.2.7 The Architect will review and approve, or take other appropriate action upon, the Contractor's submittals such as Shop Drawings, Product Data, and Samples, but only for the limited purpose of checking for conformance with information given and the design concept expressed in the Contract Documents. The Architect's action will be taken in accordance with the submittal schedule approved by the Architect or, in the absence of an approved submittal schedule, with reasonable promptness while allowing sufficient time in the Architect's professional judgment to permit adequate review. Review of such submittals is not conducted for the purpose of determining the accuracy and completeness of other details such as dimensions and quantities, or for substantiating instructions for installation or performance of equipment or systems, all of which remain the responsibility of the Contractor as required by the Contract Documents. The Architect's review of the Contractor's submittals shall not relieve the Contractor of the obligations under Sections 3.3, 3.5, and 3.12. The Architect's review shall not constitute approval of safety precautions or of any construction means, methods, techniques, sequences, or procedures. The Architect's approval of a specific item shall not indicate approval of an assembly of which the item is a component.

§ 4.2.8 The Architect will prepare Change Orders and Construction Change Directives, and may order minor changes in the Work as provided in Section 7.4. The Architect will investigate and make determinations and recommendations regarding concealed and unknown conditions as provided in Section 3.7.4.

§ 4.2.9 The Architect will conduct inspections to determine the date or dates of Substantial Completion and the date of final completion; issue Certificates of Substantial Completion pursuant to Section 9.8; receive and forward to the Owner, for the Owner's review and records, written warranties and related documents required by the Contract and assembled by the Contractor pursuant to Section 9.10; and issue a final Certificate for Payment pursuant to Section 9.10.

§ 4.2.10 If the Owner and Architect agree, the Architect will provide one or more Project representatives to assist in carrying out the Architect's responsibilities at the site. The Owner shall notify the Contractor of any change in the duties, responsibilities and limitations of authority of the Project representatives.

§ 4.2.11 The Architect will interpret and decide matters concerning performance under, and requirements of, the Contract Documents on written request of either the Owner or Contractor. The Architect's response to such requests will be made in writing within any time limits agreed upon or otherwise with reasonable promptness.

§ 4.2.12 Interpretations and decisions of the Architect will be consistent with the intent of, and reasonably inferable from, the Contract Documents and will be in writing or in the form of drawings. When making such interpretations and decisions, the Architect will endeavor to secure faithful performance by both Owner and Contractor, will not show partiality to either, and will not be liable for results of interpretations or decisions rendered in good faith.

§ 4.2.13 The Architect's decisions on matters relating to aesthetic effect will be final if consistent with the intent expressed in the Contract Documents.

§ 4.2.14 The Architect will review and respond to requests for information about the Contract Documents. The Architect's response to such requests will be made in writing within any time limits agreed upon or otherwise with reasonable promptness. If appropriate, the Architect will prepare and issue supplemental Drawings and Specifications in response to the requests for information.

## ARTICLE 5 SUBCONTRACTORS

### § 5.1 Definitions

§ 5.1.1 A Subcontractor is a person or entity who has a direct contract with the Contractor to perform a portion of the Work at the site. The term "Subcontractor" is referred to throughout the Contract Documents as if singular in



number and means a Subcontractor or an authorized representative of the Subcontractor. The term “Subcontractor” does not include a Separate Contractor or the subcontractors of a Separate Contractor.

§ 5.1.2 A Sub-subcontractor is a person or entity who has a direct or indirect contract with a Subcontractor to perform a portion of the Work at the site. The term “Sub-subcontractor” is referred to throughout the Contract Documents as if singular in number and means a Sub-subcontractor or an authorized representative of the Sub-subcontractor.

#### § 5.2 Award of Subcontracts and Other Contracts for Portions of the Work

§ 5.2.1 Unless otherwise stated in the Contract Documents, the Contractor, as soon as practicable after award of the Contract, shall notify the Owner and Architect of the persons or entities proposed for each principal portion of the Work, including those who are to furnish materials or equipment fabricated to a special design. Within 14 days of receipt of the information, the Architect may notify the Contractor whether the Owner or the Architect (1) has reasonable objection to any such proposed person or entity or (2) requires additional time for review. Failure of the Architect to provide notice within the 14-day period shall constitute notice of no reasonable objection.

§ 5.2.2 The Contractor shall not contract with a proposed person or entity to whom the Owner or Architect has made reasonable and timely objection. The Contractor shall not be required to contract with anyone to whom the Contractor has made reasonable objection.

§ 5.2.3 If the Owner or Architect has reasonable objection to a person or entity proposed by the Contractor, the Contractor shall propose another to whom the Owner or Architect has no reasonable objection. If the proposed but rejected Subcontractor was reasonably capable of performing the Work, the Contract Sum and Contract Time shall be increased or decreased by the difference, if any, occasioned by such change, and an appropriate Change Order shall be issued before commencement of the substitute Subcontractor’s Work. However, no increase in the Contract Sum or Contract Time shall be allowed for such change unless the Contractor has acted promptly and responsively in submitting names as required.

§ 5.2.4 The Contractor shall not substitute a Subcontractor, person, or entity for one previously selected if the Owner or Architect makes reasonable objection to such substitution.

#### § 5.3 Subcontractual Relations

By appropriate written agreement, the Contractor shall require each Subcontractor, to the extent of the Work to be performed by the Subcontractor, to be bound to the Contractor by terms of the Contract Documents, and to assume toward the Contractor all the obligations and responsibilities, including the responsibility for safety of the Subcontractor’s Work that the Contractor, by these Contract Documents, assumes toward the Owner and Architect. Each subcontract agreement shall preserve and protect the rights of the Owner and Architect under the Contract Documents with respect to the Work to be performed by the Subcontractor so that subcontracting thereof will not prejudice such rights, and shall allow to the Subcontractor, unless specifically provided otherwise in the subcontract agreement, the benefit of all rights, remedies, and redress against the Contractor that the Contractor, by the Contract Documents, has against the Owner. Where appropriate, the Contractor shall require each Subcontractor to enter into similar agreements with Sub-subcontractors. The Contractor shall make available to each proposed Subcontractor, prior to the execution of the subcontract agreement, copies of the Contract Documents to which the Subcontractor will be bound, and, upon written request of the Subcontractor, identify to the Subcontractor terms and conditions of the proposed subcontract agreement that may be at variance with the Contract Documents. Subcontractors will similarly make copies of applicable portions of such documents available to their respective proposed Sub-subcontractors.

#### § 5.4 Contingent Assignment of Subcontracts

§ 5.4.1 Each subcontract agreement for a portion of the Work is assigned by the Contractor to the Owner, provided that

- .1 assignment is effective only after termination of the Contract by the Owner for cause pursuant to Section 14.2 and only for those subcontract agreements that the Owner accepts by notifying the Subcontractor and Contractor; and
- .2 assignment is subject to the prior rights of the surety, if any, obligated under bond relating to the Contract.

When the Owner accepts the assignment of a subcontract agreement, the Owner assumes the Contractor's rights and obligations under the subcontract.

§ 5.4.2 Upon such assignment, if the Work has been suspended for more than 30 days, the Subcontractor's compensation shall be equitably adjusted for increases in cost resulting from the suspension.

§ 5.4.3 Upon assignment to the Owner under this Section 5.4, the Owner may further assign the subcontract to a successor contractor or other entity. If the Owner assigns the subcontract to a successor contractor or other entity, the Owner shall nevertheless remain legally responsible for all of the successor contractor's obligations under the subcontract.

## ARTICLE 6 CONSTRUCTION BY OWNER OR BY SEPARATE CONTRACTORS

### § 6.1 Owner's Right to Perform Construction and to Award Separate Contracts

§ 6.1.1 The term "Separate Contractor(s)" shall mean other contractors retained by the Owner under separate agreements. The Owner reserves the right to perform construction or operations related to the Project with the Owner's own forces, and with Separate Contractors retained under Conditions of the Contract substantially similar to those of this Contract, including those provisions of the Conditions of the Contract related to insurance and waiver of subrogation.

§ 6.1.2 When separate contracts are awarded for different portions of the Project or other construction or operations on the site, the term "Contractor" in the Contract Documents in each case shall mean the Contractor who executes each separate Owner-Contractor Agreement.

§ 6.1.3 The Owner shall provide for coordination of the activities of the Owner's own forces and of each Separate Contractor with the Work of the Contractor, who shall cooperate with them. The Contractor shall participate with any Separate Contractors and the Owner in reviewing their construction schedules. The Contractor shall make any revisions to its construction schedule deemed necessary after a joint review and mutual agreement. The construction schedules shall then constitute the schedules to be used by the Contractor, Separate Contractors, and the Owner until subsequently revised.

§ 6.1.4 Unless otherwise provided in the Contract Documents, when the Owner performs construction or operations related to the Project with the Owner's own forces or with Separate Contractors, the Owner or its Separate Contractors shall have the same obligations and rights that the Contractor has under the Conditions of the Contract, including, without excluding others, those stated in Article 3, this Article 6, and Articles 10, 11, and 12.

### § 6.2 Mutual Responsibility

§ 6.2.1 The Contractor shall afford the Owner and Separate Contractors reasonable opportunity for introduction and storage of their materials and equipment and performance of their activities, and shall connect and coordinate the Contractor's construction and operations with theirs as required by the Contract Documents.

§ 6.2.2 If part of the Contractor's Work depends for proper execution or results upon construction or operations by the Owner or a Separate Contractor, the Contractor shall, prior to proceeding with that portion of the Work, promptly notify the Architect of apparent discrepancies or defects in the construction or operations by the Owner or Separate Contractor that would render it unsuitable for proper execution and results of the Contractor's Work. Failure of the Contractor to notify the Architect of apparent discrepancies or defects prior to proceeding with the Work shall constitute an acknowledgment that the Owner's or Separate Contractor's completed or partially completed construction is fit and proper to receive the Contractor's Work. The Contractor shall not be responsible for discrepancies or defects in the construction or operations by the Owner or Separate Contractor that are not apparent.

§ 6.2.3 The Contractor shall reimburse the Owner for costs the Owner incurs that are payable to a Separate Contractor because of the Contractor's delays, improperly timed activities or defective construction. The Owner shall be responsible to the Contractor for costs the Contractor incurs because of a Separate Contractor's delays, improperly timed activities, damage to the Work or defective construction.

§ 6.2.4 The Contractor shall promptly remedy damage that the Contractor wrongfully causes to completed or partially completed construction or to property of the Owner or Separate Contractor as provided in Section 10.2.5.

§ 6.2.5 The Owner and each Separate Contractor shall have the same responsibilities for cutting and patching as are described for the Contractor in Section 3.14.

### § 6.3 Owner's Right to Clean Up

If a dispute arises among the Contractor, Separate Contractors, and the Owner as to the responsibility under their respective contracts for maintaining the premises and surrounding area free from waste materials and rubbish, the Owner may clean up and the Architect will allocate the cost among those responsible.

## ARTICLE 7 CHANGES IN THE WORK

### § 7.1 General

§ 7.1.1 Changes in the Work may be accomplished after execution of the Contract, and without invalidating the Contract, by Change Order, Construction Change Directive or order for a minor change in the Work, subject to the limitations stated in this Article 7 and elsewhere in the Contract Documents.

§ 7.1.2 A Change Order shall be based upon agreement among the Owner, Contractor, and Architect. A Construction Change Directive requires agreement by the Owner and Architect and may or may not be agreed to by the Contractor. An order for a minor change in the Work may be issued by the Architect alone.

§ 7.1.3 Changes in the Work shall be performed under applicable provisions of the Contract Documents. The Contractor shall proceed promptly with changes in the Work, unless otherwise provided in the Change Order, Construction Change Directive, or order for a minor change in the Work.

### § 7.2 Change Orders

§ 7.2.1 A Change Order is a written instrument prepared by the Architect and signed by the Owner, Contractor, and Architect stating their agreement upon all of the following:

- .1 The change in the Work;
- .2 The amount of the adjustment, if any, in the Contract Sum; and
- .3 The extent of the adjustment, if any, in the Contract Time.

### § 7.3 Construction Change Directives

§ 7.3.1 A Construction Change Directive is a written order prepared by the Architect and signed by the Owner and Architect, directing a change in the Work prior to agreement on adjustment, if any, in the Contract Sum or Contract Time, or both. The Owner may by Construction Change Directive, without invalidating the Contract, order changes in the Work within the general scope of the Contract consisting of additions, deletions, or other revisions, the Contract Sum and Contract Time being adjusted accordingly.

§ 7.3.2 A Construction Change Directive shall be used in the absence of total agreement on the terms of a Change Order.

§ 7.3.3 If the Construction Change Directive provides for an adjustment to the Contract Sum, the adjustment shall be based on one of the following methods:

- .1 Mutual acceptance of a lump sum properly itemized and supported by sufficient substantiating data to permit evaluation;
- .2 Unit prices stated in the Contract Documents or subsequently agreed upon;
- .3 Cost to be determined in a manner agreed upon by the parties and a mutually acceptable fixed or percentage fee; or
- .4 As provided in Section 7.3.4.

§ 7.3.4 If the Contractor does not respond promptly or disagrees with the method for adjustment in the Contract Sum, the Architect shall determine the adjustment on the basis of reasonable expenditures and savings of those performing the Work attributable to the change, including, in case of an increase in the Contract Sum, an amount for overhead and profit as set forth in the Agreement, or if no such amount is set forth in the Agreement, a reasonable amount. In such case, and also under Section 7.3.3.3, the Contractor shall keep and present, in such form as the Architect may prescribe, an itemized accounting together with appropriate supporting data. Unless otherwise provided in the Contract Documents, costs for the purposes of this Section 7.3.4 shall be limited to the following:

- .1 Costs of labor, including applicable payroll taxes, fringe benefits required by agreement or custom, workers' compensation insurance, and other employee costs approved by the Architect;

- 2 Costs of materials, supplies, and equipment, including cost of transportation, whether incorporated or consumed;
- 3 Rental costs of machinery and equipment, exclusive of hand tools, whether rented from the Contractor or others;
- 4 Costs of premiums for all bonds and insurance, permit fees, and sales, use, or similar taxes, directly related to the change; and
- 5 Costs of supervision and field office personnel directly attributable to the change.

§ 7.3.5 If the Contractor disagrees with the adjustment in the Contract Time, the Contractor may make a Claim in accordance with applicable provisions of Article 15.

§ 7.3.6 Upon receipt of a Construction Change Directive, the Contractor shall promptly proceed with the change in the Work involved and advise the Architect of the Contractor's agreement or disagreement with the method, if any, provided in the Construction Change Directive for determining the proposed adjustment in the Contract Sum or Contract Time.

§ 7.3.7 A Construction Change Directive signed by the Contractor indicates the Contractor's agreement therewith, including adjustment in Contract Sum and Contract Time or the method for determining them. Such agreement shall be effective immediately and shall be recorded as a Change Order.

§ 7.3.8 The amount of credit to be allowed by the Contractor to the Owner for a deletion or change that results in a net decrease in the Contract Sum shall be actual net cost as confirmed by the Architect. When both additions and credits covering related Work or substitutions are involved in a change, the allowance for overhead and profit shall be figured on the basis of net increase, if any, with respect to that change.

§ 7.3.9 Pending final determination of the total cost of a Construction Change Directive to the Owner, the Contractor may request payment for Work completed under the Construction Change Directive in Applications for Payment. The Architect will make an interim determination for purposes of monthly certification for payment for those costs and certify for payment the amount that the Architect determines, in the Architect's professional judgment, to be reasonably justified. The Architect's interim determination of cost shall adjust the Contract Sum on the same basis as a Change Order, subject to the right of either party to disagree and assert a Claim in accordance with Article 15.

§ 7.3.10 When the Owner and Contractor agree with a determination made by the Architect concerning the adjustments in the Contract Sum and Contract Time, or otherwise reach agreement upon the adjustments, such agreement shall be effective immediately and the Architect will prepare a Change Order. Change Orders may be issued for all or any part of a Construction Change Directive.

#### § 7.4 Minor Changes in the Work

The Architect may order minor changes in the Work that are consistent with the intent of the Contract Documents and do not involve an adjustment in the Contract Sum or an extension of the Contract Time. The Architect's order for minor changes shall be in writing. If the Contractor believes that the proposed minor change in the Work will affect the Contract Sum or Contract Time, the Contractor shall notify the Architect and shall not proceed to implement the change in the Work. If the Contractor performs the Work set forth in the Architect's order for a minor change without prior notice to the Architect that such change will affect the Contract Sum or Contract Time, the Contractor waives any adjustment to the Contract Sum or extension of the Contract Time.

### ARTICLE 8 TIME

#### § 8.1 Definitions

§ 8.1.1 Unless otherwise provided, Contract Time is the period of time, including authorized adjustments, allotted in the Contract Documents for Substantial Completion of the Work.

§ 8.1.2 The date of commencement of the Work is the date established in the Agreement.

§ 8.1.3 The date of Substantial Completion is the date certified by the Architect in accordance with Section 9.8.

§ 8.1.4 The term "day" as used in the Contract Documents shall mean calendar day unless otherwise specifically defined.

## § 8.2 Progress and Completion

§ 8.2.1 Time limits stated in the Contract Documents are of the essence of the Contract. By executing the Agreement, the Contractor confirms that the Contract Time is a reasonable period for performing the Work.

§ 8.2.2 The Contractor shall not knowingly, except by agreement or instruction of the Owner in writing, commence the Work prior to the effective date of insurance required to be furnished by the Contractor and Owner.

§ 8.2.3 The Contractor shall proceed expeditiously with adequate forces and shall achieve Substantial Completion within the Contract Time.

## § 8.3 Delays and Extensions of Time

§ 8.3.1 If the Contractor is delayed at any time in the commencement or progress of the Work by (1) an act or neglect of the Owner or Architect, of an employee of either, or of a Separate Contractor; (2) by changes ordered in the Work; (3) by labor disputes, fire, unusual delay in deliveries, unavoidable casualties, adverse weather conditions documented in accordance with Section 15.1.6.2, or other causes beyond the Contractor's control; (4) by delay authorized by the Owner pending mediation and binding dispute resolution; or (5) by other causes that the Contractor asserts, and the Architect determines, justify delay, then the Contract Time shall be extended for such reasonable time as the Architect may determine.

§ 8.3.2 Claims relating to time shall be made in accordance with applicable provisions of Article 15.

§ 8.3.3 This Section 8.3 does not preclude recovery of damages for delay by either party under other provisions of the Contract Documents.

## ARTICLE 9 PAYMENTS AND COMPLETION

### § 9.1 Contract Sum

§ 9.1.1 The Contract Sum is stated in the Agreement and, including authorized adjustments, is the total amount payable by the Owner to the Contractor for performance of the Work under the Contract Documents.

§ 9.1.2 If unit prices are stated in the Contract Documents or subsequently agreed upon, and if quantities originally contemplated are materially changed so that application of such unit prices to the actual quantities causes substantial inequity to the Owner or Contractor, the applicable unit prices shall be equitably adjusted.

### § 9.2 Schedule of Values

Where the Contract is based on a stipulated sum or Guaranteed Maximum Price, the Contractor shall submit a schedule of values to the Architect before the first Application for Payment, allocating the entire Contract Sum to the various portions of the Work. The schedule of values shall be prepared in the form, and supported by the data to substantiate its accuracy, required by the Architect. This schedule, unless objected to by the Architect, shall be used as a basis for reviewing the Contractor's Applications for Payment. Any changes to the schedule of values shall be submitted to the Architect and supported by such data to substantiate its accuracy as the Architect may require, and unless objected to by the Architect, shall be used as a basis for reviewing the Contractor's subsequent Applications for Payment.

### § 9.3 Applications for Payment

§ 9.3.1 At least ten days before the date established for each progress payment, the Contractor shall submit to the Architect an itemized Application for Payment prepared in accordance with the schedule of values, if required under Section 9.2, for completed portions of the Work. The application shall be notarized, if required, and supported by all data substantiating the Contractor's right to payment that the Owner or Architect require, such as copies of requisitions, and releases and waivers of liens from Subcontractors and suppliers, and shall reflect retainage if provided for in the Contract Documents.

§ 9.3.1.1 As provided in Section 7.3.9, such applications may include requests for payment on account of changes in the Work that have been properly authorized by Construction Change Directives, or by interim determinations of the Architect, but not yet included in Change Orders.

§ 9.3.1.2 Applications for Payment shall not include requests for payment for portions of the Work for which the Contractor does not intend to pay a Subcontractor or supplier, unless such Work has been performed by others whom the Contractor intends to pay.



§ 9.3.2 Unless otherwise provided in the Contract Documents, payments shall be made on account of materials and equipment delivered and suitably stored at the site for subsequent incorporation in the Work. If approved in advance by the Owner, payment may similarly be made for materials and equipment suitably stored off the site at a location agreed upon in writing. Payment for materials and equipment stored on or off the site shall be conditioned upon compliance by the Contractor with procedures satisfactory to the Owner to establish the Owner's title to such materials and equipment or otherwise protect the Owner's interest, and shall include the costs of applicable insurance, storage, and transportation to the site, for such materials and equipment stored off the site.

§ 9.3.3 The Contractor warrants that title to all Work covered by an Application for Payment will pass to the Owner no later than the time of payment. The Contractor further warrants that upon submittal of an Application for Payment all Work for which Certificates for Payment have been previously issued and payments received from the Owner shall, to the best of the Contractor's knowledge, information, and belief, be free and clear of liens, claims, security interests, or encumbrances, in favor of the Contractor, Subcontractors, suppliers, or other persons or entities that provided labor, materials, and equipment relating to the Work.

#### § 9.4 Certificates for Payment

§ 9.4.1 The Architect will, within seven days after receipt of the Contractor's Application for Payment, either (1) issue to the Owner a Certificate for Payment in the full amount of the Application for Payment, with a copy to the Contractor; or (2) issue to the Owner a Certificate for Payment for such amount as the Architect determines is properly due, and notify the Contractor and Owner of the Architect's reasons for withholding certification in part as provided in Section 9.5.1; or (3) withhold certification of the entire Application for Payment, and notify the Contractor and Owner of the Architect's reason for withholding certification in whole as provided in Section 9.5.1.

§ 9.4.2 The issuance of a Certificate for Payment will constitute a representation by the Architect to the Owner, based on the Architect's evaluation of the Work and the data in the Application for Payment, that, to the best of the Architect's knowledge, information, and belief, the Work has progressed to the point indicated, the quality of the Work is in accordance with the Contract Documents, and that the Contractor is entitled to payment in the amount certified. The foregoing representations are subject to an evaluation of the Work for conformance with the Contract Documents upon Substantial Completion, to results of subsequent tests and inspections, to correction of minor deviations from the Contract Documents prior to completion, and to specific qualifications expressed by the Architect. However, the issuance of a Certificate for Payment will not be a representation that the Architect has (1) made exhaustive or continuous on-site inspections to check the quality or quantity of the Work; (2) reviewed construction means, methods, techniques, sequences, or procedures; (3) reviewed copies of requisitions received from Subcontractors and suppliers and other data requested by the Owner to substantiate the Contractor's right to payment; or (4) made examination to ascertain how or for what purpose the Contractor has used money previously paid on account of the Contract Sum.

#### § 9.5 Decisions to Withhold Certification

§ 9.5.1 The Architect may withhold a Certificate for Payment in whole or in part, to the extent reasonably necessary to protect the Owner, if in the Architect's opinion the representations to the Owner required by Section 9.4.2 cannot be made. If the Architect is unable to certify payment in the amount of the Application, the Architect will notify the Contractor and Owner as provided in Section 9.4.1. If the Contractor and Architect cannot agree on a revised amount, the Architect will promptly issue a Certificate for Payment for the amount for which the Architect is able to make such representations to the Owner. The Architect may also withhold a Certificate for Payment or, because of subsequently discovered evidence, may nullify the whole or a part of a Certificate for Payment previously issued, to such extent as may be necessary in the Architect's opinion to protect the Owner from loss for which the Contractor is responsible, including loss resulting from acts and omissions described in Section 3.3.2, because of

- .1 defective Work not remedied;
  - .2 third party claims filed or reasonable evidence indicating probable filing of such claims, unless security acceptable to the Owner is provided by the Contractor;
  - .3 failure of the Contractor to make payments properly to Subcontractors or suppliers for labor, materials or equipment;
  - .4 reasonable evidence that the Work cannot be completed for the unpaid balance of the Contract Sum;
  - .5 damage to the Owner or a Separate Contractor;
  - .6 reasonable evidence that the Work will not be completed within the Contract Time, and that the unpaid balance would not be adequate to cover actual or liquidated damages for the anticipated delay;
- or



.7 repeated failure to carry out the Work in accordance with the Contract Documents.

§ 9.5.2 When either party disputes the Architect's decision regarding a Certificate for Payment under Section 9.5.1, in whole or in part, that party may submit a Claim in accordance with Article 15.

§ 9.5.3 When the reasons for withholding certification are removed, certification will be made for amounts previously withheld.

§ 9.5.4 If the Architect withholds certification for payment under Section 9.5.1.3, the Owner may, at its sole option, issue joint checks to the Contractor and to any Subcontractor or supplier to whom the Contractor failed to make payment for Work properly performed or material or equipment suitably delivered. If the Owner makes payments by joint check, the Owner shall notify the Architect and the Contractor shall reflect such payment on its next Application for Payment.

#### § 9.6 Progress Payments

§ 9.6.1 After the Architect has issued a Certificate for Payment, the Owner shall make payment in the manner and within the time provided in the Contract Documents, and shall so notify the Architect.

§ 9.6.2 The Contractor shall pay each Subcontractor, no later than seven days after receipt of payment from the Owner, the amount to which the Subcontractor is entitled, reflecting percentages actually retained from payments to the Contractor on account of the Subcontractor's portion of the Work. The Contractor shall, by appropriate agreement with each Subcontractor, require each Subcontractor to make payments to Sub-subcontractors in a similar manner.

§ 9.6.3 The Architect will, on request, furnish to a Subcontractor, if practicable, information regarding percentages of completion or amounts applied for by the Contractor and action taken thereon by the Architect and Owner on account of portions of the Work done by such Subcontractor.

§ 9.6.4 The Owner has the right to request written evidence from the Contractor that the Contractor has properly paid Subcontractors and suppliers amounts paid by the Owner to the Contractor for subcontracted Work. If the Contractor fails to furnish such evidence within seven days, the Owner shall have the right to contact Subcontractors and suppliers to ascertain whether they have been properly paid. Neither the Owner nor Architect shall have an obligation to pay, or to see to the payment of money to, a Subcontractor or supplier, except as may otherwise be required by law.

§ 9.6.5 The Contractor's payments to suppliers shall be treated in a manner similar to that provided in Sections 9.6.2, 9.6.3 and 9.6.4.

§ 9.6.6 A Certificate for Payment, a progress payment, or partial or entire use or occupancy of the Project by the Owner shall not constitute acceptance of Work not in accordance with the Contract Documents.

§ 9.6.7 Unless the Contractor provides the Owner with a payment bond in the full penal sum of the Contract Sum, payments received by the Contractor for Work properly performed by Subcontractors or provided by suppliers shall be held by the Contractor for those Subcontractors or suppliers who performed Work or furnished materials, or both, under contract with the Contractor for which payment was made by the Owner. Nothing contained herein shall require money to be placed in a separate account and not commingled with money of the Contractor, create any fiduciary liability or tort liability on the part of the Contractor for breach of trust, or entitle any person or entity to an award of punitive damages against the Contractor for breach of the requirements of this provision.

§ 9.6.8 Provided the Owner has fulfilled its payment obligations under the Contract Documents, the Contractor shall defend and indemnify the Owner from all loss, liability, damage or expense, including reasonable attorney's fees and litigation expenses, arising out of any lien claim or other claim for payment by any Subcontractor or supplier of any tier. Upon receipt of notice of a lien claim or other claim for payment, the Owner shall notify the Contractor. If approved by the applicable court, when required, the Contractor may substitute a surety bond for the property against which the lien or other claim for payment has been asserted.

## § 9.7 Failure of Payment

If the Architect does not issue a Certificate for Payment, through no fault of the Contractor, within seven days after receipt of the Contractor's Application for Payment, or if the Owner does not pay the Contractor within seven days after the date established in the Contract Documents, the amount certified by the Architect or awarded by binding dispute resolution, then the Contractor may, upon seven additional days' notice to the Owner and Architect, stop the Work until payment of the amount owing has been received. The Contract Time shall be extended appropriately and the Contract Sum shall be increased by the amount of the Contractor's reasonable costs of shutdown, delay and start-up, plus interest as provided for in the Contract Documents.

## § 9.8 Substantial Completion

§ 9.8.1 Substantial Completion is the stage in the progress of the Work when the Work or designated portion thereof is sufficiently complete in accordance with the Contract Documents so that the Owner can occupy or utilize the Work for its intended use.

§ 9.8.2 When the Contractor considers that the Work, or a portion thereof which the Owner agrees to accept separately, is substantially complete, the Contractor shall prepare and submit to the Architect a comprehensive list of items to be completed or corrected prior to final payment. Failure to include an item on such list does not alter the responsibility of the Contractor to complete all Work in accordance with the Contract Documents.

§ 9.8.3 Upon receipt of the Contractor's list, the Architect will make an inspection to determine whether the Work or designated portion thereof is substantially complete. If the Architect's inspection discloses any item, whether or not included on the Contractor's list, which is not sufficiently complete in accordance with the Contract Documents so that the Owner can occupy or utilize the Work or designated portion thereof for its intended use, the Contractor shall, before issuance of the Certificate of Substantial Completion, complete or correct such item upon notification by the Architect. In such case, the Contractor shall then submit a request for another inspection by the Architect to determine Substantial Completion.

§ 9.8.4 When the Work or designated portion thereof is substantially complete, the Architect will prepare a Certificate of Substantial Completion that shall establish the date of Substantial Completion; establish responsibilities of the Owner and Contractor for security, maintenance, heat, utilities, damage to the Work and insurance; and fix the time within which the Contractor shall finish all items on the list accompanying the Certificate. Warranties required by the Contract Documents shall commence on the date of Substantial Completion of the Work or designated portion thereof unless otherwise provided in the Certificate of Substantial Completion.

§ 9.8.5 The Certificate of Substantial Completion shall be submitted to the Owner and Contractor for their written acceptance of responsibilities assigned to them in the Certificate. Upon such acceptance, and consent of surety if any, the Owner shall make payment of retainage applying to the Work or designated portion thereof. Such payment shall be adjusted for Work that is incomplete or not in accordance with the requirements of the Contract Documents.

## § 9.9 Partial Occupancy or Use

§ 9.9.1 The Owner may occupy or use any completed or partially completed portion of the Work at any stage when such portion is designated by separate agreement with the Contractor, provided such occupancy or use is consented to by the insurer and authorized by public authorities having jurisdiction over the Project. Such partial occupancy or use may commence whether or not the portion is substantially complete, provided the Owner and Contractor have accepted in writing the responsibilities assigned to each of them for payments, retainage, if any, security, maintenance, heat, utilities, damage to the Work and insurance, and have agreed in writing concerning the period for correction of the Work and commencement of warranties required by the Contract Documents. When the Contractor considers a portion substantially complete, the Contractor shall prepare and submit a list to the Architect as provided under Section 9.8.2. Consent of the Contractor to partial occupancy or use shall not be unreasonably withheld. The stage of the progress of the Work shall be determined by written agreement between the Owner and Contractor or, if no agreement is reached, by decision of the Architect.

§ 9.9.2 Immediately prior to such partial occupancy or use, the Owner, Contractor, and Architect shall jointly inspect the area to be occupied or portion of the Work to be used in order to determine and record the condition of the Work.

§ 9.9.3 Unless otherwise agreed upon, partial occupancy or use of a portion or portions of the Work shall not constitute acceptance of Work not complying with the requirements of the Contract Documents.

## § 9.10 Final Completion and Final Payment

§ 9.10.1 Upon receipt of the Contractor's notice that the Work is ready for final inspection and acceptance and upon receipt of a final Application for Payment, the Architect will promptly make such inspection. When the Architect finds the Work acceptable under the Contract Documents and the Contract fully performed, the Architect will promptly issue a final Certificate for Payment stating that to the best of the Architect's knowledge, information and belief, and on the basis of the Architect's on-site visits and inspections, the Work has been completed in accordance with the Contract Documents and that the entire balance found to be due the Contractor and noted in the final Certificate is due and payable. The Architect's final Certificate for Payment will constitute a further representation that conditions listed in Section 9.10.2 as precedent to the Contractor's being entitled to final payment have been fulfilled.

§ 9.10.2 Neither final payment nor any remaining retained percentage shall become due until the Contractor submits to the Architect (1) an affidavit that payrolls, bills for materials and equipment, and other indebtedness connected with the Work for which the Owner or the Owner's property might be responsible or encumbered (less amounts withheld by Owner) have been paid or otherwise satisfied, (2) a certificate evidencing that insurance required by the Contract Documents to remain in force after final payment is currently in effect, (3) a written statement that the Contractor knows of no reason that the insurance will not be renewable to cover the period required by the Contract Documents, (4) consent of surety, if any, to final payment, (5) documentation of any special warranties, such as manufacturers' warranties or specific Subcontractor warranties, and (6) if required by the Owner, other data establishing payment or satisfaction of obligations, such as receipts and releases and waivers of liens, claims, security interests, or encumbrances arising out of the Contract, to the extent and in such form as may be designated by the Owner. If a Subcontractor refuses to furnish a release or waiver required by the Owner, the Contractor may furnish a bond satisfactory to the Owner to indemnify the Owner against such lien, claim, security interest, or encumbrance. If a lien, claim, security interest, or encumbrance remains unsatisfied after payments are made, the Contractor shall refund to the Owner all money that the Owner may be compelled to pay in discharging the lien, claim, security interest, or encumbrance, including all costs and reasonable attorneys' fees.

§ 9.10.3 If, after Substantial Completion of the Work, final completion thereof is materially delayed through no fault of the Contractor or by issuance of Change Orders affecting final completion, and the Architect so confirms, the Owner shall, upon application by the Contractor and certification by the Architect, and without terminating the Contract, make payment of the balance due for that portion of the Work fully completed, corrected, and accepted. If the remaining balance for Work not fully completed or corrected is less than retainage stipulated in the Contract Documents, and if bonds have been furnished, the written consent of the surety to payment of the balance due for that portion of the Work fully completed and accepted shall be submitted by the Contractor to the Architect prior to certification of such payment. Such payment shall be made under terms and conditions governing final payment, except that it shall not constitute a waiver of Claims.

§ 9.10.4 The making of final payment shall constitute a waiver of Claims by the Owner except those arising from

- .1 liens, Claims, security interests, or encumbrances arising out of the Contract and unsettled;
- .2 failure of the Work to comply with the requirements of the Contract Documents;
- .3 terms of special warranties required by the Contract Documents; or
- .4 audits performed by the Owner, if permitted by the Contract Documents, after final payment.

§ 9.10.5 Acceptance of final payment by the Contractor, a Subcontractor, or a supplier, shall constitute a waiver of claims by that payee except those previously made in writing and identified by that payee as unsettled at the time of final Application for Payment.

## ARTICLE 10 PROTECTION OF PERSONS AND PROPERTY

### § 10.1 Safety Precautions and Programs

The Contractor shall be responsible for initiating, maintaining, and supervising all safety precautions and programs in connection with the performance of the Contract.

### § 10.2 Safety of Persons and Property

§ 10.2.1 The Contractor shall take reasonable precautions for safety of, and shall provide reasonable protection to prevent damage, injury, or loss to

- .1 employees on the Work and other persons who may be affected thereby;

- 2 the Work and materials and equipment to be incorporated therein, whether in storage on or off the site, under care, custody, or control of the Contractor, a Subcontractor, or a Sub-subcontractor; and
- 3 other property at the site or adjacent thereto, such as trees, shrubs, lawns, walks, pavements, roadways, structures, and utilities not designated for removal, relocation, or replacement in the course of construction.

§ 10.2.2 The Contractor shall comply with, and give notices required by applicable laws, statutes, ordinances, codes, rules and regulations, and lawful orders of public authorities, bearing on safety of persons or property or their protection from damage, injury, or loss.

§ 10.2.3 The Contractor shall implement, erect, and maintain, as required by existing conditions and performance of the Contract, reasonable safeguards for safety and protection, including posting danger signs and other warnings against hazards; promulgating safety regulations; and notifying the owners and users of adjacent sites and utilities of the safeguards.

§ 10.2.4 When use or storage of explosives or other hazardous materials or equipment, or unusual methods are necessary for execution of the Work, the Contractor shall exercise utmost care and carry on such activities under supervision of properly qualified personnel.

§ 10.2.5 The Contractor shall promptly remedy damage and loss (other than damage or loss insured under property insurance required by the Contract Documents) to property referred to in Sections 10.2.1.2 and 10.2.1.3 caused in whole or in part by the Contractor, a Subcontractor, a Sub-subcontractor, or anyone directly or indirectly employed by any of them, or by anyone for whose acts they may be liable and for which the Contractor is responsible under Sections 10.2.1.2 and 10.2.1.3. The Contractor may make a Claim for the cost to remedy the damage or loss to the extent such damage or loss is attributable to acts or omissions of the Owner or Architect or anyone directly or indirectly employed by either of them, or by anyone for whose acts either of them may be liable, and not attributable to the fault or negligence of the Contractor. The foregoing obligations of the Contractor are in addition to the Contractor's obligations under Section 3.18.

§ 10.2.6 The Contractor shall designate a responsible member of the Contractor's organization at the site whose duty shall be the prevention of accidents. This person shall be the Contractor's superintendent unless otherwise designated by the Contractor in writing to the Owner and Architect.

§ 10.2.7 The Contractor shall not permit any part of the construction or site to be loaded so as to cause damage or create an unsafe condition.

#### § 10.2.8 Injury or Damage to Person or Property

If either party suffers injury or damage to person or property because of an act or omission of the other party, or of others for whose acts such party is legally responsible, notice of the injury or damage, whether or not insured, shall be given to the other party within a reasonable time not exceeding 21 days after discovery. The notice shall provide sufficient detail to enable the other party to investigate the matter.

#### § 10.3 Hazardous Materials and Substances

§ 10.3.1 The Contractor is responsible for compliance with any requirements included in the Contract Documents regarding hazardous materials or substances. If the Contractor encounters a hazardous material or substance not addressed in the Contract Documents and if reasonable precautions will be inadequate to prevent foreseeable bodily injury or death to persons resulting from a material or substance, including but not limited to asbestos or polychlorinated biphenyl (PCB), encountered on the site by the Contractor, the Contractor shall, upon recognizing the condition, immediately stop Work in the affected area and notify the Owner and Architect of the condition.

§ 10.3.2 Upon receipt of the Contractor's notice, the Owner shall obtain the services of a licensed laboratory to verify the presence or absence of the material or substance reported by the Contractor and, in the event such material or substance is found to be present, to cause it to be rendered harmless. Unless otherwise required by the Contract Documents, the Owner shall furnish in writing to the Contractor and Architect the names and qualifications of persons or entities who are to perform tests verifying the presence or absence of the material or substance or who are to perform the task of removal or safe containment of the material or substance. The Contractor and the Architect will promptly reply to the Owner in writing stating whether or not either has reasonable objection to the persons or entities proposed by the Owner. If either the Contractor or Architect has an objection to a person or entity proposed

by the Owner, the Owner shall propose another to whom the Contractor and the Architect have no reasonable objection. When the material or substance has been rendered harmless, Work in the affected area shall resume upon written agreement of the Owner and Contractor. By Change Order, the Contract Time shall be extended appropriately and the Contract Sum shall be increased by the amount of the Contractor's reasonable additional costs of shutdown, delay, and start-up.

§ 10.3.3 To the fullest extent permitted by law, the Owner shall indemnify and hold harmless the Contractor, Subcontractors, Architect, Architect's consultants, and agents and employees of any of them from and against claims, damages, losses, and expenses, including but not limited to attorneys' fees, arising out of or resulting from performance of the Work in the affected area if in fact the material or substance presents the risk of bodily injury or death as described in Section 10.3.1 and has not been rendered harmless, provided that such claim, damage, loss, or expense is attributable to bodily injury, sickness, disease or death, or to injury to or destruction of tangible property (other than the Work itself), except to the extent that such damage, loss, or expense is due to the fault or negligence of the party seeking indemnity.

§ 10.3.4 The Owner shall not be responsible under this Section 10.3 for hazardous materials or substances the Contractor brings to the site unless such materials or substances are required by the Contract Documents. The Owner shall be responsible for hazardous materials or substances required by the Contract Documents, except to the extent of the Contractor's fault or negligence in the use and handling of such materials or substances.

§ 10.3.5 The Contractor shall reimburse the Owner for the cost and expense the Owner incurs (1) for remediation of hazardous materials or substances the Contractor brings to the site and negligently handles, or (2) where the Contractor fails to perform its obligations under Section 10.3.1, except to the extent that the cost and expense are due to the Owner's fault or negligence.

§ 10.3.6 If, without negligence on the part of the Contractor, the Contractor is held liable by a government agency for the cost of remediation of a hazardous material or substance solely by reason of performing Work as required by the Contract Documents, the Owner shall reimburse the Contractor for all cost and expense thereby incurred.

#### § 10.4 Emergencies

In an emergency affecting safety of persons or property, the Contractor shall act, at the Contractor's discretion, to prevent threatened damage, injury, or loss. Additional compensation or extension of time claimed by the Contractor on account of an emergency shall be determined as provided in Article 15 and Article 7.

### ARTICLE 11 INSURANCE AND BONDS

#### § 11.1 Contractor's Insurance and Bonds

§ 11.1.1 The Contractor shall purchase and maintain insurance of the types and limits of liability, containing the endorsements, and subject to the terms and conditions, as described in the Agreement or elsewhere in the Contract Documents. The Contractor shall purchase and maintain the required insurance from an insurance company or insurance companies lawfully authorized to issue insurance in the jurisdiction where the Project is located. The Owner, Architect, and Architect's consultants shall be named as additional insureds under the Contractor's commercial general liability policy or as otherwise described in the Contract Documents.

§ 11.1.2 The Contractor shall provide surety bonds of the types, for such penal sums, and subject to such terms and conditions as required by the Contract Documents. The Contractor shall purchase and maintain the required bonds from a company or companies lawfully authorized to issue surety bonds in the jurisdiction where the Project is located.

§ 11.1.3 Upon the request of any person or entity appearing to be a potential beneficiary of bonds covering payment of obligations arising under the Contract, the Contractor shall promptly furnish a copy of the bonds or shall authorize a copy to be furnished.

§ 11.1.4 Notice of Cancellation or Expiration of Contractor's Required Insurance. Within three (3) business days of the date the Contractor becomes aware of an impending or actual cancellation or expiration of any insurance required by the Contract Documents, the Contractor shall provide notice to the Owner of such impending or actual cancellation or expiration. Upon receipt of notice from the Contractor, the Owner shall, unless the lapse in coverage arises from an act or omission of the Owner, have the right to stop the Work until the lapse in coverage has been cured by the



procurement of replacement coverage by the Contractor. The furnishing of notice by the Contractor shall not relieve the Contractor of any contractual obligation to provide any required coverage.

## § 11.2 Owner's Insurance

§ 11.2.1 The Owner shall purchase and maintain insurance of the types and limits of liability, containing the endorsements, and subject to the terms and conditions, as described in the Agreement or elsewhere in the Contract Documents. The Owner shall purchase and maintain the required insurance from an insurance company or insurance companies lawfully authorized to issue insurance in the jurisdiction where the Project is located.

§ 11.2.2 Failure to Purchase Required Property Insurance. If the Owner fails to purchase and maintain the required property insurance, with all of the coverages and in the amounts described in the Agreement or elsewhere in the Contract Documents, the Owner shall inform the Contractor in writing prior to commencement of the Work. Upon receipt of notice from the Owner, the Contractor may delay commencement of the Work and may obtain insurance that will protect the interests of the Contractor, Subcontractors, and Sub-Subcontractors in the Work. When the failure to provide coverage has been cured or resolved, the Contract Sum and Contract Time shall be equitably adjusted. In the event the Owner fails to procure coverage, the Owner waives all rights against the Contractor, Subcontractors, and Sub-subcontractors to the extent the loss to the Owner would have been covered by the insurance to have been procured by the Owner. The cost of the insurance shall be charged to the Owner by a Change Order. If the Owner does not provide written notice, and the Contractor is damaged by the failure or neglect of the Owner to purchase or maintain the required insurance, the Owner shall reimburse the Contractor for all reasonable costs and damages attributable thereto.

§ 11.2.3 Notice of Cancellation or Expiration of Owner's Required Property Insurance. Within three (3) business days of the date the Owner becomes aware of an impending or actual cancellation or expiration of any property insurance required by the Contract Documents, the Owner shall provide notice to the Contractor of such impending or actual cancellation or expiration. Unless the lapse in coverage arises from an act or omission of the Contractor: (1) the Contractor, upon receipt of notice from the Owner, shall have the right to stop the Work until the lapse in coverage has been cured by the procurement of replacement coverage by either the Owner or the Contractor; (2) the Contract Time and Contract Sum shall be equitably adjusted; and (3) the Owner waives all rights against the Contractor, Subcontractors, and Sub-subcontractors to the extent any loss to the Owner would have been covered by the insurance had it not expired or been cancelled. If the Contractor purchases replacement coverage, the cost of the insurance shall be charged to the Owner by an appropriate Change Order. The furnishing of notice by the Owner shall not relieve the Owner of any contractual obligation to provide required insurance.

## § 11.3 Waivers of Subrogation

§ 11.3.1 The Owner and Contractor waive all rights against (1) each other and any of their subcontractors, sub-subcontractors, agents, and employees, each of the other; (2) the Architect and Architect's consultants; and (3) Separate Contractors, if any, and any of their subcontractors, sub-subcontractors, agents, and employees, for damages caused by fire, or other causes of loss, to the extent those losses are covered by property insurance required by the Agreement or other property insurance applicable to the Project, except such rights as they have to proceeds of such insurance. The Owner or Contractor, as appropriate, shall require similar written waivers in favor of the individuals and entities identified above from the Architect, Architect's consultants, Separate Contractors, subcontractors, and sub-subcontractors. The policies of insurance purchased and maintained by each person or entity agreeing to waive claims pursuant to this section 11.3.1 shall not prohibit this waiver of subrogation. This waiver of subrogation shall be effective as to a person or entity (1) even though that person or entity would otherwise have a duty of indemnification, contractual or otherwise, (2) even though that person or entity did not pay the insurance premium directly or indirectly, or (3) whether or not the person or entity had an insurable interest in the damaged property.

§ 11.3.2 If during the Project construction period the Owner insures properties, real or personal or both, at or adjacent to the site by property insurance under policies separate from those insuring the Project, or if after final payment property insurance is to be provided on the completed Project through a policy or policies other than those insuring the Project during the construction period, to the extent permissible by such policies, the Owner waives all rights in accordance with the terms of Section 11.3.1 for damages caused by fire or other causes of loss covered by this separate property insurance.

## § 11.4 Loss of Use, Business Interruption, and Delay in Completion Insurance



The Owner, at the Owner's option, may purchase and maintain insurance that will protect the Owner against loss of use of the Owner's property, or the inability to conduct normal operations, due to fire or other causes of loss. The Owner waives all rights of action against the Contractor and Architect for loss of use of the Owner's property, due to fire or other hazards however caused.

#### §11.5 Adjustment and Settlement of Insured Loss

§ 11.5.1 A loss insured under the property insurance required by the Agreement shall be adjusted by the Owner as fiduciary and made payable to the Owner as fiduciary for the insureds, as their interests may appear, subject to requirements of any applicable mortgagee clause and of Section 11.5.2. The Owner shall pay the Architect and Contractor their just shares of insurance proceeds received by the Owner, and by appropriate agreements the Architect and Contractor shall make payments to their consultants and Subcontractors in similar manner.

§ 11.5.2 Prior to settlement of an insured loss, the Owner shall notify the Contractor of the terms of the proposed settlement as well as the proposed allocation of the insurance proceeds. The Contractor shall have 14 days from receipt of notice to object to the proposed settlement or allocation of the proceeds. If the Contractor does not object, the Owner shall settle the loss and the Contractor shall be bound by the settlement and allocation. Upon receipt, the Owner shall deposit the insurance proceeds in a separate account and make the appropriate distributions. Thereafter, if no other agreement is made or the Owner does not terminate the Contract for convenience, the Owner and Contractor shall execute a Change Order for reconstruction of the damaged or destroyed Work in the amount allocated for that purpose. If the Contractor timely objects to either the terms of the proposed settlement or the allocation of the proceeds, the Owner may proceed to settle the insured loss, and any dispute between the Owner and Contractor arising out of the settlement or allocation of the proceeds shall be resolved pursuant to Article 15. Pending resolution of any dispute, the Owner may issue a Construction Change Directive for the reconstruction of the damaged or destroyed Work.

### ARTICLE 12 UNCOVERING AND CORRECTION OF WORK

#### § 12.1 Uncovering of Work

§ 12.1.1 If a portion of the Work is covered contrary to the Architect's request or to requirements specifically expressed in the Contract Documents, it must, if requested in writing by the Architect, be uncovered for the Architect's examination and be replaced at the Contractor's expense without change in the Contract Time.

§ 12.1.2 If a portion of the Work has been covered that the Architect has not specifically requested to examine prior to its being covered, the Architect may request to see such Work and it shall be uncovered by the Contractor. If such Work is in accordance with the Contract Documents, the Contractor shall be entitled to an equitable adjustment to the Contract Sum and Contract Time as may be appropriate. If such Work is not in accordance with the Contract Documents, the costs of uncovering the Work, and the cost of correction, shall be at the Contractor's expense.

#### § 12.2 Correction of Work

##### § 12.2.1 Before Substantial Completion

The Contractor shall promptly correct Work rejected by the Architect or failing to conform to the requirements of the Contract Documents, discovered before Substantial Completion and whether or not fabricated, installed or completed. Costs of correcting such rejected Work, including additional testing and inspections, the cost of uncovering and replacement, and compensation for the Architect's services and expenses made necessary thereby, shall be at the Contractor's expense.

##### § 12.2.2 After Substantial Completion

§ 12.2.2.1 In addition to the Contractor's obligations under Section 3.5, if, within one year after the date of Substantial Completion of the Work or designated portion thereof or after the date for commencement of warranties established under Section 9.9.1, or by terms of any applicable special warranty required by the Contract Documents, any of the Work is found to be not in accordance with the requirements of the Contract Documents, the Contractor shall correct it promptly after receipt of notice from the Owner to do so, unless the Owner has previously given the Contractor a written acceptance of such condition. The Owner shall give such notice promptly after discovery of the condition. During the one-year period for correction of Work, if the Owner fails to notify the Contractor and give the Contractor an opportunity to make the correction, the Owner waives the rights to require correction by the Contractor and to make a claim for breach of warranty. If the Contractor fails to correct nonconforming Work within a reasonable time during that period after receipt of notice from the Owner or Architect, the Owner may correct it in accordance with Section 2.5.

§ 12.2.2.2 The one-year period for correction of Work shall be extended with respect to portions of Work first performed after Substantial Completion by the period of time between Substantial Completion and the actual completion of that portion of the Work.

§ 12.2.2.3 The one-year period for correction of Work shall not be extended by corrective Work performed by the Contractor pursuant to this Section 12.2.

§ 12.2.3 The Contractor shall remove from the site portions of the Work that are not in accordance with the requirements of the Contract Documents and are neither corrected by the Contractor nor accepted by the Owner.

§ 12.2.4 The Contractor shall bear the cost of correcting destroyed or damaged construction of the Owner or Separate Contractors, whether completed or partially completed, caused by the Contractor's correction or removal of Work that is not in accordance with the requirements of the Contract Documents.

§ 12.2.5 Nothing contained in this Section 12.2 shall be construed to establish a period of limitation with respect to other obligations the Contractor has under the Contract Documents. Establishment of the one-year period for correction of Work as described in Section 12.2.2 relates only to the specific obligation of the Contractor to correct the Work, and has no relationship to the time within which the obligation to comply with the Contract Documents may be sought to be enforced, nor to the time within which proceedings may be commenced to establish the Contractor's liability with respect to the Contractor's obligations other than specifically to correct the Work.

### § 12.3 Acceptance of Nonconforming Work

If the Owner prefers to accept Work that is not in accordance with the requirements of the Contract Documents, the Owner may do so instead of requiring its removal and correction, in which case the Contract Sum will be reduced as appropriate and equitable. Such adjustment shall be effected whether or not final payment has been made.

## ARTICLE 13 MISCELLANEOUS PROVISIONS

### § 13.1 Governing Law

The Contract shall be governed by the law of the place where the Project is located, excluding that jurisdiction's choice of law rules. If the parties have selected arbitration as the method of binding dispute resolution, the Federal Arbitration Act shall govern Section 15.4.

### § 13.2 Successors and Assigns

§ 13.2.1 The Owner and Contractor respectively bind themselves, their partners, successors, assigns, and legal representatives to covenants, agreements, and obligations contained in the Contract Documents. Except as provided in Section 13.2.2, neither party to the Contract shall assign the Contract as a whole without written consent of the other. If either party attempts to make an assignment without such consent, that party shall nevertheless remain legally responsible for all obligations under the Contract.

§ 13.2.2 The Owner may, without consent of the Contractor, assign the Contract to a lender providing construction financing for the Project, if the lender assumes the Owner's rights and obligations under the Contract Documents. The Contractor shall execute all consents reasonably required to facilitate the assignment.

### § 13.3 Rights and Remedies

§ 13.3.1 Duties and obligations imposed by the Contract Documents and rights and remedies available thereunder shall be in addition to and not a limitation of duties, obligations, rights, and remedies otherwise imposed or available by law.

§ 13.3.2 No action or failure to act by the Owner, Architect, or Contractor shall constitute a waiver of a right or duty afforded them under the Contract, nor shall such action or failure to act constitute approval of or acquiescence in a breach thereunder, except as may be specifically agreed upon in writing.

### § 13.4 Tests and Inspections

§ 13.4.1 Tests, inspections, and approvals of portions of the Work shall be made as required by the Contract Documents and by applicable laws, statutes, ordinances, codes, rules, and regulations or lawful orders of public authorities. Unless otherwise provided, the Contractor shall make arrangements for such tests, inspections, and approvals with an independent testing laboratory or entity acceptable to the Owner, or with the appropriate public authority, and shall bear all related costs of tests, inspections, and approvals. The Contractor shall give the Architect

timely notice of when and where tests and inspections are to be made so that the Architect may be present for such procedures. The Owner shall bear costs of tests, inspections, or approvals that do not become requirements until after bids are received or negotiations concluded. The Owner shall directly arrange and pay for tests, inspections, or approvals where building codes or applicable laws or regulations so require.

§ 13.4.2 If the Architect, Owner, or public authorities having jurisdiction determine that portions of the Work require additional testing, inspection, or approval not included under Section 13.4.1, the Architect will, upon written authorization from the Owner, instruct the Contractor to make arrangements for such additional testing, inspection, or approval, by an entity acceptable to the Owner, and the Contractor shall give timely notice to the Architect of when and where tests and inspections are to be made so that the Architect may be present for such procedures. Such costs, except as provided in Section 13.4.3, shall be at the Owner's expense.

§ 13.4.3 If procedures for testing, inspection, or approval under Sections 13.4.1 and 13.4.2 reveal failure of the portions of the Work to comply with requirements established by the Contract Documents, all costs made necessary by such failure, including those of repeated procedures and compensation for the Architect's services and expenses, shall be at the Contractor's expense.

§ 13.4.4 Required certificates of testing, inspection, or approval shall, unless otherwise required by the Contract Documents, be secured by the Contractor and promptly delivered to the Architect.

§ 13.4.5 If the Architect is to observe tests, inspections, or approvals required by the Contract Documents, the Architect will do so promptly and, where practicable, at the normal place of testing.

§ 13.4.6 Tests or inspections conducted pursuant to the Contract Documents shall be made promptly to avoid unreasonable delay in the Work.

#### § 13.5 Interest

Payments due and unpaid under the Contract Documents shall bear interest from the date payment is due at the rate the parties agree upon in writing or, in the absence thereof, at the legal rate prevailing from time to time at the place where the Project is located.

### ARTICLE 14 TERMINATION OR SUSPENSION OF THE CONTRACT

#### § 14.1 Termination by the Contractor

§ 14.1.1 The Contractor may terminate the Contract if the Work is stopped for a period of 30 consecutive days through no act or fault of the Contractor, a Subcontractor, a Sub-subcontractor, their agents or employees, or any other persons or entities performing portions of the Work, for any of the following reasons:

- .1 Issuance of an order of a court or other public authority having jurisdiction that requires all Work to be stopped;
- .2 An act of government, such as a declaration of national emergency, that requires all Work to be stopped;
- .3 Because the Architect has not issued a Certificate for Payment and has not notified the Contractor of the reason for withholding certification as provided in Section 9.4.1, or because the Owner has not made payment on a Certificate for Payment within the time stated in the Contract Documents; or
- .4 The Owner has failed to furnish to the Contractor reasonable evidence as required by Section 2.2.

§ 14.1.2 The Contractor may terminate the Contract if, through no act or fault of the Contractor, a Subcontractor, a Sub-subcontractor, their agents or employees, or any other persons or entities performing portions of the Work, repeated suspensions, delays, or interruptions of the entire Work by the Owner as described in Section 14.3, constitute in the aggregate more than 100 percent of the total number of days scheduled for completion, or 120 days in any 365-day period, whichever is less.

§ 14.1.3 If one of the reasons described in Section 14.1.1 or 14.1.2 exists, the Contractor may, upon seven days' notice to the Owner and Architect, terminate the Contract and recover from the Owner payment for Work executed, as well as reasonable overhead and profit on Work not executed, and costs incurred by reason of such termination.

§ 14.1.4 If the Work is stopped for a period of 60 consecutive days through no act or fault of the Contractor, a Subcontractor, a Sub-subcontractor, or their agents or employees or any other persons or entities performing portions of the Work because the Owner has repeatedly failed to fulfill the Owner's obligations under the Contract

Documents with respect to matters important to the progress of the Work, the Contractor may, upon seven additional days' notice to the Owner and the Architect, terminate the Contract and recover from the Owner as provided in Section 14.1.3.

§ 14.2 Termination by the Owner for Cause

§ 14.2.1 The Owner may terminate the Contract if the Contractor

- .1 repeatedly refuses or fails to supply enough properly skilled workers or proper materials;
- .2 fails to make payment to Subcontractors or suppliers in accordance with the respective agreements between the Contractor and the Subcontractors or suppliers;
- .3 repeatedly disregards applicable laws, statutes, ordinances, codes, rules and regulations, or lawful orders of a public authority; or
- .4 otherwise is guilty of substantial breach of a provision of the Contract Documents.

§ 14.2.2 When any of the reasons described in Section 14.2.1 exist, and upon certification by the Architect that sufficient cause exists to justify such action, the Owner may, without prejudice to any other rights or remedies of the Owner and after giving the Contractor and the Contractor's surety, if any, seven days' notice, terminate employment of the Contractor and may, subject to any prior rights of the surety:

- .1 Exclude the Contractor from the site and take possession of all materials, equipment, tools, and construction equipment and machinery thereon owned by the Contractor;
- .2 Accept assignment of subcontracts pursuant to Section 5.4; and
- .3 Finish the Work by whatever reasonable method the Owner may deem expedient. Upon written request of the Contractor, the Owner shall furnish to the Contractor a detailed accounting of the costs incurred by the Owner in finishing the Work.

§ 14.2.3 When the Owner terminates the Contract for one of the reasons stated in Section 14.2.1, the Contractor shall not be entitled to receive further payment until the Work is finished.

§ 14.2.4 If the unpaid balance of the Contract Sum exceeds costs of finishing the Work, including compensation for the Architect's services and expenses made necessary thereby, and other damages incurred by the Owner and not expressly waived, such excess shall be paid to the Contractor. If such costs and damages exceed the unpaid balance, the Contractor shall pay the difference to the Owner. The amount to be paid to the Contractor or Owner, as the case may be, shall be certified by the Initial Decision Maker, upon application, and this obligation for payment shall survive termination of the Contract.

§ 14.3 Suspension by the Owner for Convenience

§ 14.3.1 The Owner may, without cause, order the Contractor in writing to suspend, delay or interrupt the Work, in whole or in part for such period of time as the Owner may determine.

§ 14.3.2 The Contract Sum and Contract Time shall be adjusted for increases in the cost and time caused by suspension, delay, or interruption under Section 14.3.1. Adjustment of the Contract Sum shall include profit. No adjustment shall be made to the extent

- .1 that performance is, was, or would have been, so suspended, delayed, or interrupted, by another cause for which the Contractor is responsible; or
- .2 that an equitable adjustment is made or denied under another provision of the Contract.

§ 14.4 Termination by the Owner for Convenience

§ 14.4.1 The Owner may, at any time, terminate the Contract for the Owner's convenience and without cause.

§ 14.4.2 Upon receipt of notice from the Owner of such termination for the Owner's convenience, the Contractor shall

- .1 cease operations as directed by the Owner in the notice;
- .2 take actions necessary, or that the Owner may direct, for the protection and preservation of the Work; and
- .3 except for Work directed to be performed prior to the effective date of termination stated in the notice, terminate all existing subcontracts and purchase orders and enter into no further subcontracts and purchase orders.

§ 14.4.3 In case of such termination for the Owner's convenience, the Owner shall pay the Contractor for Work

properly executed; costs incurred by reason of the termination, including costs attributable to termination of Subcontracts; and the termination fee, if any, set forth in the Agreement.

## ARTICLE 15 CLAIMS AND DISPUTES

### § 15.1 Claims

#### § 15.1.1 Definition

A Claim is a demand or assertion by one of the parties seeking, as a matter of right, payment of money, a change in the Contract Time, or other relief with respect to the terms of the Contract. The term "Claim" also includes other disputes and matters in question between the Owner and Contractor arising out of or relating to the Contract. The responsibility to substantiate Claims shall rest with the party making the Claim. This Section 15.1.1 does not require the Owner to file a Claim in order to impose liquidated damages in accordance with the Contract Documents.

#### § 15.1.2 Time Limits on Claims

The Owner and Contractor shall commence all Claims and causes of action against the other and arising out of or related to the Contract, whether in contract, tort, breach of warranty or otherwise, in accordance with the requirements of the binding dispute resolution method selected in the Agreement and within the period specified by applicable law, but in any case not more than 10 years after the date of Substantial Completion of the Work. The Owner and Contractor waive all Claims and causes of action not commenced in accordance with this Section 15.1.2.

#### § 15.1.3 Notice of Claims

§ 15.1.3.1 Claims by either the Owner or Contractor, where the condition giving rise to the Claim is first discovered prior to expiration of the period for correction of the Work set forth in Section 12.2.2, shall be initiated by notice to the other party and to the Initial Decision Maker with a copy sent to the Architect, if the Architect is not serving as the Initial Decision Maker. Claims by either party under this Section 15.1.3.1 shall be initiated within 21 days after occurrence of the event giving rise to such Claim or within 21 days after the claimant first recognizes the condition giving rise to the Claim, whichever is later.

§ 15.1.3.2 Claims by either the Owner or Contractor, where the condition giving rise to the Claim is first discovered after expiration of the period for correction of the Work set forth in Section 12.2.2, shall be initiated by notice to the other party. In such event, no decision by the Initial Decision Maker is required.

#### § 15.1.4 Continuing Contract Performance

§ 15.1.4.1 Pending final resolution of a Claim, except as otherwise agreed in writing or as provided in Section 9.7 and Article 14, the Contractor shall proceed diligently with performance of the Contract and the Owner shall continue to make payments in accordance with the Contract Documents.

§ 15.1.4.2 The Contract Sum and Contract Time shall be adjusted in accordance with the Initial Decision Maker's decision, subject to the right of either party to proceed in accordance with this Article 15. The Architect will issue Certificates for Payment in accordance with the decision of the Initial Decision Maker.

#### § 15.1.5 Claims for Additional Cost

If the Contractor wishes to make a Claim for an increase in the Contract Sum, notice as provided in Section 15.1.3 shall be given before proceeding to execute the portion of the Work that is the subject of the Claim. Prior notice is not required for Claims relating to an emergency endangering life or property arising under Section 10.4.

#### § 15.1.6 Claims for Additional Time

§ 15.1.6.1 If the Contractor wishes to make a Claim for an increase in the Contract Time, notice as provided in Section 15.1.3 shall be given. The Contractor's Claim shall include an estimate of cost and of probable effect of delay on progress of the Work. In the case of a continuing delay, only one Claim is necessary.

§ 15.1.6.2 If adverse weather conditions are the basis for a Claim for additional time, such Claim shall be documented by data substantiating that weather conditions were abnormal for the period of time, could not have been reasonably anticipated, and had an adverse effect on the scheduled construction.

#### § 15.1.7 Waiver of Claims for Consequential Damages

The Contractor and Owner waive Claims against each other for consequential damages arising out of or relating to this Contract. This mutual waiver includes



- .1 damages incurred by the Owner for rental expenses, for losses of use, income, profit, financing, business and reputation, and for loss of management or employee productivity or of the services of such persons; and
- .2 damages incurred by the Contractor for principal office expenses including the compensation of personnel stationed there, for losses of financing, business and reputation, and for loss of profit, except anticipated profit arising directly from the Work.

This mutual waiver is applicable, without limitation, to all consequential damages due to either party's termination in accordance with Article 14. Nothing contained in this Section 15.1.7 shall be deemed to preclude assessment of liquidated damages, when applicable, in accordance with the requirements of the Contract Documents.

## § 15.2 Initial Decision

§ 15.2.1 Claims, excluding those where the condition giving rise to the Claim is first discovered after expiration of the period for correction of the Work set forth in Section 12.2.2 or arising under Sections 10.3, 10.4, and 11.5, shall be referred to the Initial Decision Maker for initial decision. The Architect will serve as the Initial Decision Maker, unless otherwise indicated in the Agreement. Except for those Claims excluded by this Section 15.2.1, an initial decision shall be required as a condition precedent to mediation of any Claim. If an initial decision has not been rendered within 30 days after the Claim has been referred to the Initial Decision Maker, the party asserting the Claim may demand mediation and binding dispute resolution without a decision having been rendered. Unless the Initial Decision Maker and all affected parties agree, the Initial Decision Maker will not decide disputes between the Contractor and persons or entities other than the Owner.

§ 15.2.2 The Initial Decision Maker will review Claims and within ten days of the receipt of a Claim take one or more of the following actions: (1) request additional supporting data from the claimant or a response with supporting data from the other party, (2) reject the Claim in whole or in part, (3) approve the Claim, (4) suggest a compromise, or (5) advise the parties that the Initial Decision Maker is unable to resolve the Claim if the Initial Decision Maker lacks sufficient information to evaluate the merits of the Claim or if the Initial Decision Maker concludes that, in the Initial Decision Maker's sole discretion, it would be inappropriate for the Initial Decision Maker to resolve the Claim.

§ 15.2.3 In evaluating Claims, the Initial Decision Maker may, but shall not be obligated to, consult with or seek information from either party or from persons with special knowledge or expertise who may assist the Initial Decision Maker in rendering a decision. The Initial Decision Maker may request the Owner to authorize retention of such persons at the Owner's expense.

§ 15.2.4 If the Initial Decision Maker requests a party to provide a response to a Claim or to furnish additional supporting data, such party shall respond, within ten days after receipt of the request, and shall either (1) provide a response on the requested supporting data, (2) advise the Initial Decision Maker when the response or supporting data will be furnished, or (3) advise the Initial Decision Maker that no supporting data will be furnished. Upon receipt of the response or supporting data, if any, the Initial Decision Maker will either reject or approve the Claim in whole or in part.

§ 15.2.5 The Initial Decision Maker will render an initial decision approving or rejecting the Claim, or indicating that the Initial Decision Maker is unable to resolve the Claim. This initial decision shall (1) be in writing; (2) state the reasons therefor; and (3) notify the parties and the Architect, if the Architect is not serving as the Initial Decision Maker, of any change in the Contract Sum or Contract Time or both. The initial decision shall be final and binding on the parties but subject to mediation and, if the parties fail to resolve their dispute through mediation, to binding dispute resolution.

§ 15.2.6 Either party may file for mediation of an initial decision at any time, subject to the terms of Section 15.2.6.1.

§ 15.2.6.1 Either party may, within 30 days from the date of receipt of an initial decision, demand in writing that the other party file for mediation. If such a demand is made and the party receiving the demand fails to file for mediation within 30 days after receipt thereof, then both parties waive their rights to mediate or pursue binding dispute resolution proceedings with respect to the initial decision.



§ 15.2.7 In the event of a Claim against the Contractor, the Owner may, but is not obligated to, notify the surety, if any, of the nature and amount of the Claim. If the Claim relates to a possibility of a Contractor's default, the Owner may, but is not obligated to, notify the surety and request the surety's assistance in resolving the controversy.

§ 15.2.8 If a Claim relates to or is the subject of a mechanic's lien, the party asserting such Claim may proceed in accordance with applicable law to comply with the lien notice or filing deadlines.

### § 15.3 Mediation

§ 15.3.1 Claims, disputes, or other matters in controversy arising out of or related to the Contract, except those waived as provided for in Sections 9.10.4, 9.10.5, and 15.1.7, shall be subject to mediation as a condition precedent to binding dispute resolution.

§ 15.3.2 The parties shall endeavor to resolve their Claims by mediation which, unless the parties mutually agree otherwise, shall be administered by the American Arbitration Association in accordance with its Construction Industry Mediation Procedures in effect on the date of the Agreement. A request for mediation shall be made in writing, delivered to the other party to the Contract, and filed with the person or entity administering the mediation. The request may be made concurrently with the filing of binding dispute resolution proceedings but, in such event, mediation shall proceed in advance of binding dispute resolution proceedings, which shall be stayed pending mediation for a period of 60 days from the date of filing, unless stayed for a longer period by agreement of the parties or court order. If an arbitration is stayed pursuant to this Section 15.3.2, the parties may nonetheless proceed to the selection of the arbitrator(s) and agree upon a schedule for later proceedings.

§ 15.3.3 Either party may, within 30 days from the date that mediation has been concluded without resolution of the dispute or 60 days after mediation has been demanded without resolution of the dispute, demand in writing that the other party file for binding dispute resolution. If such a demand is made and the party receiving the demand fails to file for binding dispute resolution within 60 days after receipt thereof, then both parties waive their rights to binding dispute resolution proceedings with respect to the initial decision.

§ 15.3.4 The parties shall share the mediator's fee and any filing fees equally. The mediation shall be held in the place where the Project is located, unless another location is mutually agreed upon. Agreements reached in mediation shall be enforceable as settlement agreements in any court having jurisdiction thereof.

### § 15.4 Arbitration

§ 15.4.1 If the parties have selected arbitration as the method for binding dispute resolution in the Agreement, any Claim subject to, but not resolved by, mediation shall be subject to arbitration which, unless the parties mutually agree otherwise, shall be administered by the American Arbitration Association in accordance with its Construction Industry Arbitration Rules in effect on the date of the Agreement. The Arbitration shall be conducted in the place where the Project is located, unless another location is mutually agreed upon. A demand for arbitration shall be made in writing, delivered to the other party to the Contract, and filed with the person or entity administering the arbitration. The party filing a notice of demand for arbitration must assert in the demand all Claims then known to that party on which arbitration is permitted to be demanded.

§ 15.4.1.1 A demand for arbitration shall be made no earlier than concurrently with the filing of a request for mediation, but in no event shall it be made after the date when the institution of legal or equitable proceedings based on the Claim would be barred by the applicable statute of limitations. For statute of limitations purposes, receipt of a written demand for arbitration by the person or entity administering the arbitration shall constitute the institution of legal or equitable proceedings based on the Claim.

§ 15.4.2 The award rendered by the arbitrator or arbitrators shall be final, and judgment may be entered upon it in accordance with applicable law in any court having jurisdiction thereof.

§ 15.4.3 The foregoing agreement to arbitrate and other agreements to arbitrate with an additional person or entity duly consented to by parties to the Agreement, shall be specifically enforceable under applicable law in any court having jurisdiction thereof.

### § 15.4.4 Consolidation or Joinder

§ 15.4.4.1 Subject to the rules of the American Arbitration Association or other applicable arbitration rules, either party may consolidate an arbitration conducted under this Agreement with any other arbitration to which it is a party

provided that (1) the arbitration agreement governing the other arbitration permits consolidation, (2) the arbitrations to be consolidated substantially involve common questions of law or fact, and (3) the arbitrations employ materially similar procedural rules and methods for selecting arbitrator(s).

§ 15.4.4.2 Subject to the rules of the American Arbitration Association or other applicable arbitration rules, either party may include by joinder persons or entities substantially involved in a common question of law or fact whose presence is required if complete relief is to be accorded in arbitration, provided that the party sought to be joined consents in writing to such joinder. Consent to arbitration involving an additional person or entity shall not constitute consent to arbitration of any claim, dispute or other matter in question not described in the written consent.

§ 15.4.4.3 The Owner and Contractor grant to any person or entity made a party to an arbitration conducted under this Section 15.4, whether by joinder or consolidation, the same rights of joinder and consolidation as those of the Owner and Contractor under this Agreement.



## SECTION 02 41 19 - SELECTIVE DEMOLITION

### PART 1 - GENERAL

#### 1.1 SUMMARY

A. Section Includes:

1. Demolition and removal of selected portions of building or structure.

#### 1.2 MATERIALS OWNERSHIP

- A. Unless otherwise indicated, demolition waste becomes property of Contractor.

#### 1.3 PREINSTALLATION MEETINGS

- A. Pre-demolition Conference: Conduct conference at project site.

#### 1.4 INFORMATIONAL SUBMITTALS

- A. Engineering Survey: Submit engineering survey of condition of building.
- B. Proposed Protection Measures: Submit report, including Drawings, that indicates the measures proposed for protecting individuals and property. Indicate proposed locations and construction of barriers.
- C. Schedule of selective demolition activities with starting and ending dates for each activity.
- D. Pre-demolition photographs or video.

#### 1.5 FIELD CONDITIONS

- A. Owner will occupy portions of building immediately adjacent to selective demolition area. Conduct selective demolition so Owner's operations will not be disrupted.
- B. Conditions existing at time of inspection for bidding purpose will be maintained by Owner as far as practical.
1. Before selective demolition, Owner will remove the following items:
    - a. Storage racking along exterior walls in work area
- C. Notify Architect of discrepancies between existing conditions and Drawings before proceeding with selective demolition.

- D. Hazardous Materials: It is not expected that hazardous materials will be encountered in the Work.
    - 1. Hazardous materials will be removed by Owner before start of the Work.
    - 2. If suspected hazardous materials are encountered, do not disturb; immediately notify Architect and Owner. Hazardous materials will be removed by Owner under a separate contract.
  - E. Storage or sale of removed items or materials on-site is not permitted.
  - F. Utility Service: Maintain existing utilities indicated to remain in service and protect them against damage during selective demolition operations.
    - 1. Maintain fire-protection facilities in service during selective demolition operations.
  - G. Arrange selective demolition schedule so as not to interfere with Owner's operations.
- 1.6 WARRANTY
- A. Existing Warranties: Remove, replace, patch, and repair materials and surfaces cut or damaged during selective demolition, by methods and with materials and using approved contractors so as not to void existing warranties.

## PART 2 - PRODUCTS

### 2.1 PERFORMANCE REQUIREMENTS

- A. Regulatory Requirements: Comply with governing EPA notification regulations before beginning selective demolition. Comply with hauling and disposal regulations of authorities having jurisdiction.
- B. Standards: Comply with ANSI/ASSP A10.6 and NFPA 241.

## PART 3 - EXECUTION

### 3.1 EXAMINATION

- A. Verify that utilities have been disconnected and capped before starting selective demolition operations.
- B. Perform an engineering survey of condition of building to determine whether removing any element might result in structural deficiency or unplanned collapse of any portion of structure or adjacent structures during selective building demolition operations.

### 3.2 PREPARATION

### 3.3 UTILITY SERVICES AND MECHANICAL/ELECTRICAL SYSTEMS

- A. Existing Services/Systems to Remain: Maintain services/systems indicated to remain and protect them against damage.
  - 1. Owner will arrange to shut off indicated services/systems as required for demolition when requested by Contractor.
  - 2. If services/systems are required to be removed, relocated, or abandoned, provide temporary services/systems that bypass area of selective demolition and that maintain continuity of services/systems to other parts of building.

### 3.4 PROTECTION

- A. Temporary Protection: Provide temporary barricades and other protection required to prevent injury to people and damage to adjacent buildings and facilities to remain.
- B. Temporary Shoring: Design, provide, and maintain shoring, bracing, and structural supports as required to preserve stability and prevent movement, settlement, or collapse of construction and finishes to remain, and to prevent unexpected or uncontrolled movement or collapse of construction being demolished.
- C. Remove temporary barricades and protections where hazards no longer exist.

### 3.5 SELECTIVE DEMOLITION

- A. General: Demolish and remove existing construction only to the extent required by new construction and as indicated. Use methods required to complete the Work within limitations of governing regulations and as follows:
  - 1. Neatly cut openings and holes plumb, square, and true to dimensions required. Use cutting methods least likely to damage construction to remain or adjoining construction. Use hand tools or small power tools designed for sawing or grinding, not hammering and chopping. Temporarily cover openings to remain.
  - 2. Cut or drill from the exposed or finished side into concealed surfaces to avoid marring existing finished surfaces.
  - 3. Do not use cutting torches until work area is cleared of flammable materials. At concealed spaces, such as duct and pipe interiors, verify condition and contents of hidden space before starting flame-cutting operations. Maintain portable fire-suppression devices during flame-cutting operations.
  - 4. Maintain fire watch during and for at least one hour after flame-cutting operations.
  - 5. Locate selective demolition equipment and remove debris and materials so as not to impose excessive loads on supporting walls, floors, or framing.
  - 6. Dispose of demolished items and materials promptly.

- B. Site Access and Temporary Controls: Conduct selective demolition and debris-removal operations to ensure minimum interference with roads, streets, walks, walkways, and other adjacent occupied and used facilities.
- C. Existing Items to Remain: Protect construction indicated to remain against damage and soiling during selective demolition. When permitted by Architect, items may be removed to a suitable, protected storage location during selective demolition and reinstalled in their original locations after selective demolition operations are complete.

### 3.6 CLEANING

- A. Remove demolition waste materials from Project site.
  - 1. Do not allow demolished materials to accumulate on-site.
  - 2. Remove and transport debris in a manner that will prevent spillage on adjacent surfaces and areas.
  - 3. Comply with requirements specified in Section 01 74 19 "Construction Waste Management and Disposal."
- B. Burning: Do not burn demolished materials.
- C. Clean adjacent structures and improvements of dust, dirt, and debris caused by selective demolition operations. Return adjacent areas to condition existing before selective demolition operations began.

END OF SECTION 02 41 19



## SECTION 03 10 00 - CONCRETE FORMING AND ACCESSORIES

### PART 1 - GENERAL

#### 1.1 SUMMARY

A. Section Includes:

1. Form-facing material for cast-in-place concrete.
2. Shoring, bracing, and anchoring.

#### 1.2 PREINSTALLATION MEETINGS

- A. Preinstallation Conference: Conduct conference at the project site.

#### 1.3 ACTION SUBMITTALS

A. Product Data: For each of the following:

1. Exposed surface form-facing material.
2. Concealed surface form-facing material.
3. Form ties.
4. Water stops.
5. Form-release agent.

- B. Shop Drawings: Prepared by, and signed and sealed by, a qualified professional engineer responsible for their preparation, detailing fabrication, assembly, and support of forms.

1. For exposed vertical concrete walls, indicate dimensions and form tie locations.
2. Indicate dimension and locations of construction and movement joints required to construct the structure in accordance with ACI 301.

- a. Location of construction joints is subject to approval of the Architect.

3. Indicate location of water stops.

#### 1.4 INFORMATIONAL SUBMITTALS

- A. Field quality-control reports.
- B. Minutes of preinstallation conference.

## PART 2 - PRODUCTS

### 2.1 PERFORMANCE REQUIREMENTS

- A. Concrete Formwork: Design, engineer, erect, shore, brace, and maintain formwork, shores, and reshores in accordance with ACI 301, to support vertical, lateral, static, and dynamic loads, and construction loads that might be applied, until structure can support such loads, so that resulting concrete conforms to the required shapes, lines, and dimensions.
  - 1. Design wood panel forms in accordance with APA's "Concrete Forming Design/Construction Guide."
  - 2. Design formwork to limit deflection of form-facing material to 1/240 of center-to-center spacing of supports.

### 2.2 FORM-FACING MATERIALS

- A. As-Cast Surface Form-Facing Material:
  - 1. Provide continuous, true, and smooth concrete surfaces.
  - 2. Furnish in largest practicable sizes to minimize number of joints.
  - 3. Acceptable Materials: As required to comply with Surface Finish designations specified in Section 03 30 00 "Cast-In-Place Concrete, and as follows:
    - a. Plywood, metal, or other approved panel materials.
- B. Concealed Surface Form-Facing Material: Lumber, plywood, metal, plastic, or another approved material.
  - 1. Provide lumber dressed on at least two edges and one side for tight fit.

### 2.3 WATERSTOPS

- A. Flexible PVC Waterstops: U.S. Army Corps of Engineers CRD-C 572, with factory-installed metal eyelets, for embedding in concrete to prevent passage of fluids through joints, with factory fabricate corners, intersections, and directional changes.

### 2.4 RELATED MATERIALS

- A. Reglets: Fabricate reglets of not less than 0.022-inch-thick, galvanized-steel sheet. Temporarily fill or cover face opening of reglet to prevent intrusion of concrete or debris.
- B. Dovetail Anchor Slots: Hot-dip galvanized-steel sheet, not less than 0.034 inch thick, with bent tab anchors. Temporarily fill or cover face opening of slots to prevent intrusion of concrete or debris.
- C. Chamfer Strips: Wood, metal, PVC, or rubber strips, 3/4 by 3/4 inch, minimum.

- D. Rustication Strips: Wood, metal, PVC, or rubber strips, kerfed for ease of form removal.
- E. Form-Release Agent: Commercially formulated form-release agent that does not bond with, stain, or adversely affect concrete surfaces and does not impair subsequent treatments of concrete surfaces.
  - 1. Formulate form-release agent with rust inhibitor for steel form-facing materials.
  - 2. Form release agent for form liners shall be acceptable to form liner manufacturer.
- F. Form Ties: Factory-fabricated, removable or snap-off, glass-fiber-reinforced plastic or metal form ties designed to resist lateral pressure of fresh concrete on forms and to prevent spalling of concrete on removal.

### PART 3 - EXECUTION

#### 3.1 INSTALLATION OF FORMWORK

- A. Comply with ACI 301.
- B. Construct formwork, so concrete members and structures are of size, shape, alignment, elevation, and position indicated, within tolerance limits of ACI 117 and to comply with the Surface Finish designations specified in Section 03 30 00 "Cast-In-Place Concrete" for as-cast finishes.
- C. Limit concrete surface irregularities.
- D. Construct forms tight enough to prevent loss of concrete mortar.
  - 1. Minimize joints.
  - 2. Exposed Concrete: Symmetrically align joints in forms.
- E. Construct removable forms for easy removal without hammering or prying against concrete surfaces.
  - 1. Provide crush or wrecking plates where stripping may damage cast-concrete surfaces.
  - 2. Provide top forms for inclined surfaces steeper than 1.5 horizontal to 1 vertical.
  - 3. Install keyways, reglets, recesses, and other accessories, for easy removal.
- F. Do not use rust-stained, steel, form-facing material.
- G. Set edge forms, bulkheads, and intermediate screed strips for slabs to achieve required elevations and slopes in finished concrete surfaces.
  - 1. Provide and secure units to support screed strips.
  - 2. Use strike-off templates or compacting-type screeds.
- H. Provide temporary openings for cleanouts and inspection ports where interior area of formwork is inaccessible.

1. Close openings with panels tightly fitted to forms and securely braced to prevent loss of concrete mortar.
  2. Locate temporary openings in forms at inconspicuous locations.
- I. Chamfer exterior corners and edges of permanently exposed concrete.
- J. At construction joints, overlap forms onto previously placed concrete not less than 12 inches.
- K. Form openings, chases, offsets, sinkages, keyways, reglets, blocking, screeds, and bulkheads required in the Work.
1. Determine sizes and locations from trades providing such items.
  2. Obtain written approval of Architect prior to forming openings not indicated on Drawings.
- L. Construction and Movement Joints:
1. Construct joints true to line with faces perpendicular to surface plane of concrete.
  2. Install so strength and appearance of concrete are not impaired, at locations indicated or as approved by Architect.
  3. Place joints perpendicular to main reinforcement.
  4. Locate joints for beams, slabs, joists, and girders in the middle third of spans.
    - a. Offset joints in girders a minimum distance of twice the beam width from a beam-girder intersection.
  5. Locate horizontal joints in walls and columns at underside of floors, slabs, beams, and girders and at the top of footings or floor slabs.
  6. Space vertical joints in walls as indicated on Drawings.
- M. Provide temporary ports or openings in formwork where required to facilitate cleaning and inspection.
1. Locate ports and openings in bottom of vertical forms, in inconspicuous location, to allow flushing water to drain.
  2. Close temporary ports and openings with tight-fitting panels, flush with inside face of form, and neatly fitted, so joints will not be apparent in exposed concrete surfaces.
- N. Clean forms and adjacent surfaces to receive concrete. Remove chips, wood, sawdust, dirt, and other debris just before placing concrete.
- O. Retighten forms and bracing before placing concrete, as required, to prevent mortar leaks and maintain proper alignment.
- P. Coat contact surfaces of forms with form-release agent, according to manufacturer's written instructions, before placing reinforcement.

### 3.2 INSTALLATION OF EMBEDDED ITEMS

- A. Place and secure anchorage devices and other embedded items required for adjoining work that is attached to or supported by cast-in-place concrete.
  - 1. Use setting drawings, templates, diagrams, instructions, and directions furnished with items to be embedded.
  - 2. Install anchor rods, accurately located, to elevations required and complying with tolerances in Section 7.5 of AISC 303.
  - 3. Install reglets to receive waterproofing and to receive through-wall flashings in outer face of concrete frame at exterior walls, where flashing is shown at lintels, shelf angles, and other conditions.
  - 4. Install dovetail anchor slots in concrete structures, as indicated on Drawings.
  - 5. Clean embedded items immediately prior to concrete placement.

### 3.3 INSTALLATION OF WATERSTOPS

- A. Flexible Water stops: Install in construction joints and at other joints indicated to form a continuous diaphragm.
  - 1. Install in longest lengths practicable.
  - 2. Locate water stops in center of joint unless otherwise indicated on Drawings.
  - 3. Allow clearance between water stop and reinforcing steel of not less than 2 times the largest concrete aggregate size specified in Section 03 30 00 "Cast-In-Place Concrete."
  - 4. Secure water stops in correct position at 12 inches on center.
  - 5. Field fabricate joints in accordance with manufacturer's instructions using heat welding.
  - 6. Clean water stops immediately prior to placement of concrete.
  - 7. Support and protect exposed water stops during progress of the Work.

### 3.4 SHORING AND RESHORING INSTALLATION

- A. Comply with ACI 318 and ACI 301 for design, installation, and removal of shoring and reshoring.
  - 1. Do not remove shoring or reshoring until measurement of slab tolerances is complete.
- B. Plan sequence of removal of shores and reshore to avoid damage to concrete. Locate and provide adequate reshoring to support construction without excessive stress or deflection.

### 3.5 FIELD QUALITY CONTROL

- A. Testing Agency: Engage a qualified testing and inspecting agency to perform tests and inspections and to submit reports.

B. Inspections:

1. Inspect formwork for shape, location, and dimensions of the concrete member being formed.
2. Inspect insulating concrete forms for shape, location, and dimensions of the concrete member being formed.

END OF SECTION 03 10 00



## SECTION 03 20 00 - CONCRETE REINFORCING

### PART 1 - GENERAL

#### 1.1 SUMMARY

A. Section Includes:

1. Steel reinforcement bars.
2. Welded-wire reinforcement.

#### 1.2 PREINSTALLATION MEETINGS

- A. Preinstallation Conference: Conduct conference at Project Site.

#### 1.3 ACTION SUBMITTALS

A. Product Data: For the following:

1. Each type of steel reinforcement.
2. Bar supports.
3. Mechanical splice couplers.

B. Shop Drawings: Comply with ACI SP-066:

1. Include placing drawings that detail fabrication, bending, and placement.
2. Include bar sizes, lengths, materials, grades, bar schedules, stirrup spacing, bent bar diagrams, bar arrangement, location of splices, lengths of lap splices, details of mechanical splice couplers, details of welding splices, tie spacing, hoop spacing, and supports for concrete reinforcement.

C. Construction Joint Layout: Indicate proposed construction joints required to build the structure.

1. Location of construction joints is subject to approval of the Architect.

#### 1.4 INFORMATIONAL SUBMITTALS

A. Welding certificates.

1. Reinforcement to Be Welded: Welding procedure specification in accordance with AWS D1.4/D1.4M

B. Material Certificates: For each of the following, signed by manufacturers:

1. Epoxy-Coated Reinforcement: CRSI's "Epoxy Coating Plant Certification."

- C. Material Test Reports: For the following, from a qualified testing agency:
  - 1. Steel Reinforcement:
    - a. For reinforcement to be welded, mill test analysis for chemical composition and carbon equivalent of the steel in accordance with ASTM A706/A706M.
  - 2. Mechanical splice couplers.
- D. Field quality-control reports.
- E. Minutes of preinstallation conference.

#### 1.5 QUALITY ASSURANCE

- A. Welding Qualifications: Qualify procedures and personnel in accordance with AWS D1.4/D 1.4M.

### PART 2 - PRODUCTS

#### 2.1 STEEL REINFORCEMENT

- A. Reinforcing Bars: ASTM A615/A615M, Grade 60 deformed.
- B. Low-Alloy Steel Reinforcing Bars: ASTM A706/A706M, deformed.
- C. Headed-Steel Reinforcing Bars: ASTM A970/A970M.
- D. Galvanized Reinforcing Bars:
  - 1. Steel Bars: ASTM A615/A615M, Grade 60 deformed bars.
- E. Epoxy-Coated Reinforcing Bars:
  - 1. Steel Bars: ASTM A615/A615M, Grade 60 deformed bars.
  - 2. Epoxy Coating: ASTM A775/A775M with less than 2 percent damaged coating in each 12-inch bar length.
- F. Plain-Steel Welded-Wire Reinforcement: ASTM A1064/A1064M, plain, fabricated from as-drawn steel wire into flat sheets.
- G. Deformed-Steel Welded-Wire Reinforcement: ASTM A1064/A1064M, flat sheet.
- H. Galvanized-Steel Welded-Wire Reinforcement: ASTM A1064/A1064M, plain, fabricated from galvanized-steel wire into flat sheets.
- I. Epoxy-Coated Welded-Wire Reinforcement: ASTM A884/A884M, Class A coated, Type 1.

## 2.2 REINFORCEMENT ACCESSORIES

- A. Bar Supports: Bolsters, chairs, spacers, and other devices for spacing, supporting, and fastening reinforcing bars and welded-wire reinforcement in place.
  - 1. Manufacture bar supports from steel wire, plastic, or precast concrete in accordance with CRSI's "Manual of Standard Practice," of greater compressive strength than concrete.
- B. Mechanical Splice Couplers: ACI 318 Type 1, same material of reinforcing bar being spliced; mechanical-lap type.
- C. Steel Tie Wire: ASTM A1064/A1064M, annealed steel, not less than 0.0508 inch in diameter.

## 2.3 FABRICATING REINFORCEMENT

- A. Fabricate steel reinforcement according to CRSI's "Manual of Standard Practice."

## PART 3 - EXECUTION

### 3.1 PREPARATION

- A. Protection of In-Place Conditions:
  - 1. Do not cut or puncture vapor retarder.
  - 2. Repair damage and reseal vapor retarder before placing concrete.
- B. Clean reinforcement of loose rust and mill scale, earth, ice, and other foreign materials that reduce bond to concrete.

### 3.2 INSTALLATION OF STEEL REINFORCEMENT

- A. Comply with CRSI's "Manual of Standard Practice" for placing and supporting reinforcement.
- B. Accurately position, support, and secure reinforcement against displacement.
  - 1. Locate and support reinforcement with bar supports to maintain minimum concrete cover.
  - 2. Do not tack weld crossing reinforcing bars.
- C. Preserve clearance between bars of not less than 1 inch, not less than one bar diameter, or not less than 1-1/3 times size of large aggregate, whichever is greater.
- D. Provide concrete coverage in accordance with ACI 318.
- E. Set wire ties with ends directed into concrete, not toward exposed concrete surfaces.

- F. Splices: Lap splices as indicated on Drawings.
  - 1. Bars indicated to be continuous, and all vertical bars shall be lapped not less than 36 bar diameters at splices, or 24 inches, whichever is greater.
  - 2. Stagger splices in accordance with ACI 318.
  - 3. Mechanical Splice Couplers: Install in accordance with manufacturer's instructions.
  - 4. Weld reinforcing bars in accordance with AWS D1.4/D 1.4M, where indicated on Drawings.
  
- G. Install welded-wire reinforcement in longest practicable lengths.
  - 1. Support welded-wire reinforcement in accordance with CRSI "Manual of Standard Practice."
    - a. For reinforcement less than W4.0 or D4.0, continuous support spacing shall not exceed 12 inches.
  - 2. Lap edges and ends of adjoining sheets at least one wire spacing plus 2 inches for plain wire and 8 inches for deformed wire.
  - 3. Offset laps of adjoining sheet widths to prevent continuous laps in either direction.
  - 4. Lace overlaps with wire.

### 3.3 JOINTS

- A. Construction Joints: Install so strength and appearance of concrete are not impaired, at locations indicated or as approved by Architect.
  - 1. Place joints perpendicular to main reinforcement.
  - 2. Continue reinforcement across construction joints unless otherwise indicated.
  - 3. Do not continue reinforcement through sides of strip placements of floors and slabs.

### 3.4 INSTALLATION TOLERANCES

- A. Comply with ACI 117.

### 3.5 FIELD QUALITY CONTROL

- A. Testing Agency: Engage a qualified testing and inspecting agency to perform tests and inspections and to submit reports.
  
- B. Inspections:
  - 1. Steel-reinforcement placement.
  - 2. Steel-reinforcement mechanical splice couplers.
  - 3. Steel-reinforcement welding.

END OF SECTION 03 20 00

## SECTION 03 30 00 - CAST-IN-PLACE CONCRETE

### PART 1 - GENERAL

#### 1.1 SUMMARY

##### A. Section Includes:

1. Cast-in-place concrete, including concrete materials, mixture design, placement procedures, and finishes.

##### B. Related Requirements:

1. Section 03 10 00 "Concrete Forming and Accessories" for form-facing materials, form liners, insulating concrete forms, and water stops.
2. Section 03 20 00 "Concrete Reinforcing" for steel reinforcing bars and welded-wire reinforcement.
3. Section 31 20 00 "Earth Moving" for drainage fill under slabs-on-ground.

#### 1.2 DEFINITIONS

- ##### A. Cementitious Materials:
- Portland cement alone or in combination with one or more of the following: blended hydraulic cement, fly ash, slag cement, and other pozzolans materials subject to compliance with requirements.

- ##### B. Water/Cement Ratio (w/cm):
- The ratio by weight of water to cementitious materials.

#### 1.3 PREINSTALLATION MEETINGS

- ##### A. Preinstallation Conference:
- Conduct conference at Project site.

#### 1.4 ACTION SUBMITTALS

- ##### A. Product Data:
- For each of the following.

1. Portland cement.
2. Fly ash.
3. Slag cement.
4. Blended hydraulic cement.
5. Aggregates.
6. Admixtures:

- a. Include limitations of use, including restrictions on cementitious materials, supplementary cementitious materials, air entrainment, aggregates, temperature at time of concrete placement, relative humidity at time of concrete placement, curing conditions, and use of other admixtures.



7. Vapor retarders.
8. Liquid floor treatments.
9. Curing materials.
10. Joint fillers.

B. Design Mixtures: For each concrete mixture, include the following:

1. Mixture identification.
2. Maximum w/cm.
3. Slump limit.
4. Nominal maximum aggregate size.
5. Indicate amounts of mixing water to be withheld for later addition at Project site if permitted.
6. Intended placement method.
7. Submit alternate design mixtures when characteristics of materials, Project conditions, weather, test results, or other circumstances warrant adjustments.

C. Shop Drawings:

1. Construction Joint Layout: Indicate proposed construction joints required to construct the structure.
  - a. Location of construction joints is subject to approval of the Architect.

D. Concrete Schedule: For each location of each Class of concrete indicated in "Concrete Mixtures" Article, including the following:

1. Concrete Class designation.
2. Location within Project.
3. Exposure Class designation.
4. Formed Surface Finish designation and final finish.
5. Final finish for floors.
6. Curing process.
7. Floor treatment if any.

## 1.5 INFORMATIONAL SUBMITTALS

- A. Material Certificates signed by manufacturers.
- B. Material Test Reports from a qualified testing agency.
- C. Research Reports: For concrete admixtures in accordance with ICC's Acceptance Criteria AC198.
- D. Preconstruction Test Reports: For each mix design.
- E. Field quality-control reports.
- F. Minutes of preinstallation conference.

1.6 QUALITY ASSURANCE

- A. Ready-Mixed Concrete Manufacturer Qualifications: A firm experienced in manufacturing ready-mixed concrete products and that complies with ASTM C94/C94M requirements for production facilities and equipment.

1.7 PRECONSTRUCTION TESTING

- A. Preconstruction Testing Service: Engage a qualified testing agency to perform preconstruction testing on each concrete mixture.
  - 1. Include the following information in each test report:
    - a. Admixture dosage rates.
    - b. Slump.
    - c. Air content.
    - d. Seven-day compressive strength.
    - e. 28-day compressive strength.

1.8 DELIVERY, STORAGE, AND HANDLING

- A. Comply with ASTM C94/C94M and ACI 301.

1.9 FIELD CONDITIONS

- A. Cold-Weather Placement: Comply with ACI 301 and ACI 306.1.
- B. Hot-Weather Placement: Comply with ACI 301 and ACI 305.1.

PART 2 - PRODUCTS

2.1 CONCRETE, GENERAL

- A. ACI Publications: Comply with ACI 301 unless modified by requirements in the Contract Documents.

2.2 CONCRETE MATERIALS

- A. Cementitious Materials:
  - 1. Portland Cement: ASTM C150/C150M, per drawings
  - 2. Fly Ash: ASTM C618, Class C or F.
  - 3. Slag Cement: ASTM C989/C989M, Grade 100 or 120.
  - 4. Blended Hydraulic Cement: ASTM C595/C595M, type as noted in drawings.

- B. Normal-Weight Aggregates: ASTM C33/C33M. Provide aggregates from a single source.
  - 1. Maximum Coarse-Aggregate Size: 1-1/2 inches nominal.
- C. Air-Entraining Admixture: ASTM C260/C260M.
- D. Chemical Admixtures: Certified by manufacturer to be compatible with other admixtures that do not contribute water-soluble chloride ions exceeding those permitted in hardened concrete.
  - 1. Water-Reducing Admixture: ASTM C494/C494M, Type A.
  - 2. Retarding Admixture: ASTM C494/C494M, Type B.
  - 3. Water-Reducing and -Retarding Admixture: ASTM C494/C494M, Type D.
  - 4. High-Range, Water-Reducing Admixture: ASTM C494/C494M, Type F.
  - 5. High-Range, Water-Reducing and -Retarding Admixture: ASTM C494/C494M, Type G.
  - 6. Plasticizing and Retarding Admixture: ASTM C1017/C1017M, Type II.
- E. Water and Water Used to Make Ice: ASTM C94/C94M, potable or complying with ASTM C1602.

## 2.3 VAPOR RETARDERS

- A. Sheet Vapor Retarder, Class A: ASTM E1745, Class A, not less than 10 mils thick. Include manufacturer's recommended adhesive or pressure-sensitive tape.

## 2.4 LIQUID FLOOR TREATMENTS

- A. Penetrating Liquid Floor Treatment: Clear, chemically reactive, waterborne solution of inorganic silicate or silicate materials and proprietary components; odorless; that penetrates, hardens, and densifies concrete surfaces.

## 2.5 CURING MATERIALS

- A. Moisture-Retaining Cover: ASTM C171, polyethylene film burlap-polyethylene sheet.
  - 1. Color:
    - a. Ambient Temperature Below 50 deg F: Black.
    - b. Ambient Temperature between 50 deg F and 85 deg F: Any color.
    - c. Ambient Temperature Above 85 deg F: White.
- B. Curing Paper: Eight-foot-wide paper, consisting of two layers of fibered kraft paper laminated with double coating of asphalt.
- C. Water: Potable or complying with ASTM C1602/C1602M.

2.6 RELATED MATERIALS

- A. Expansion- and Isolation-Joint-Filler Strips: ASTM D1751, asphalt-saturated cellulosic fiber.
- B. Floor Slab Protective Covering: Eight-feet-wide cellulose fabric.

2.7 CONCRETE MIXTURES, GENERAL

- A. Prepare design mixtures for each type and strength of concrete, proportioned on the basis of laboratory trial mixture or field test data, or both, in accordance with ACI 301.
  - 1. Use a qualified testing agency for preparing and reporting proposed mixture designs, based on laboratory trial mixtures.

2.8 CONCRETE MIXTURES

- A. Normal-weight concrete used for footings, grade beams, and tie beams.
  - 1. Minimum Compressive Strength: As indicated on drawings at 28 days.
    - a. Exposure Class F1: 6.0 percent, plus or minus 1.5 percent at point of delivery for concrete containing 1-1/2-inch nominal maximum aggregate size.

2.9 CONCRETE MIXING

- A. Project-Site Mixing: Measure, batch, and mix concrete materials and concrete in accordance with ASTM C94/C94M. Mix concrete materials in appropriate drum-type batch machine mixer.
  - 1. For mixer capacity of 1 cu. yd. or smaller, continue mixing at least 1-1/2 minutes, but not more than five minutes after ingredients are in mixer, before any part of batch is released.
  - 2. For mixer capacity larger than 1 cu. yd., increase mixing time by 15 seconds for each additional 1 cu. yd.
  - 3. Provide batch ticket for each batch discharged and used in the Work, indicating Project identification name and number, date, mixture type, mixture time, quantity, and amount of water added. Record approximate location of final deposit in structure.

PART 3 - EXECUTION

3.1 INSTALLATION OF EMBEDDED ITEMS

- A. Place and secure anchorage devices and other embedded items required for adjoining Work that is attached to or supported by cast-in-place concrete.

1. Use setting drawings, templates, diagrams, instructions, and directions furnished with items to be embedded.
2. Install anchor rods, accurately located, to elevations required and complying with tolerances in Section 7.5 of ANSI/AISC 303.
3. Install reglets to receive waterproofing and to receive through-wall flashings in outer face of concrete frame at exterior walls, where flashing is shown at lintels, shelf angles, and other conditions.

### 3.2 INSTALLATION OF VAPOR RETARDER

- A. Sheet Vapor Retarders: Place, protect, and repair sheet vapor retarder in accordance with ASTM E1643 and manufacturer's written instructions.
  1. Install vapor retarder with longest dimension parallel with direction of concrete pour.
  2. Face laps away from exposed direction of concrete pour.
  3. Lap vapor retarder over footings and grade beams not less than 6 inches, sealing vapor retarder to concrete.
  4. Lap joints 6 inches and seal with manufacturer's recommended tape.
  5. Terminate vapor retarder at the top of floor slabs, grade beams, and pile caps, sealing entire perimeter to floor slabs, grade beams, foundation walls, or pile caps.
  6. Seal penetrations in accordance with vapor retarder manufacturer's instructions.
  7. Protect vapor retarder during placement of reinforcement and concrete.
    - a. Repair damaged areas by patching with vapor retarder material, overlapping damages area by 6 inches on all sides, and sealing to vapor retarder.

### 3.3 JOINTS

- A. Construct joints true to line, with faces perpendicular to surface plane of concrete.
- B. Construction Joints: Coordinate with floor slab pattern and concrete placement sequence.
  1. Install so strength and appearance of concrete are not impaired, at locations indicated on Drawings or as approved by Architect.
  2. Place joints perpendicular to main reinforcement.
    - a. Continue reinforcement across construction joints unless otherwise indicated.
    - b. Do not continue reinforcement through sides of strip placements of floors and slabs.
  3. Space vertical joints in walls as indicated on Drawings. Unless otherwise indicated on Drawings, locate vertical joints beside piers integral with walls, near corners, and in concealed locations where possible.

- C. Control Joints in Slabs-on-Ground: Form weakened-plane control joints, sectioning concrete into areas as indicated.
- D. Isolation Joints in Slabs-on-Ground: After removing formwork, install joint-filler strips at slab junctions with vertical surfaces, such as column pedestals, foundation walls, grade beams, and other locations, as indicated.
  - 1. Extend joint-filler strips full width and depth of joint, terminating flush with finished concrete surface unless otherwise indicated on Drawings.
  - 2. Install joint-filler strips in lengths as long as practicable. Where more than one length is required, lace or clip sections together.
- E. Doweled Joints:
  - 1. Install dowel bars and support assemblies at joints where indicated on Drawings.
  - 2. Lubricate or asphalt coat one-half of dowel bar length to prevent concrete bonding to one side of joint.
- F. Dowel Plates: Install dowel plates at joints as indicated on Drawings.

### 3.4 CONCRETE PLACEMENT

- A. Before placing concrete, verify that installation of formwork, reinforcement, embedded items, and vapor retarder is complete and that required inspections are completed.
  - 1. Immediately prior to concrete placement, inspect vapor retarder for damage and deficient installation, and repair defective areas.
  - 2. Provide continuous inspection of vapor retarder during concrete placement and make necessary repairs to damaged areas as Work progresses.
- B. Notify Architect and testing and inspection agencies 24 hours prior to commencement of concrete placement.
- C. Before test sampling and placing concrete, water may be added at Project site, subject to limitations of ACI 301, but not to exceed the amount indicated on the concrete delivery ticket.
- D. Deposit concrete continuously in one layer or in horizontal layers of such thickness that no new concrete is placed on concrete that has hardened enough to cause seams or planes of weakness.
  - 1. If a section cannot be placed continuously, provide construction joints as indicated.
  - 2. Deposit concrete to avoid segregation.
  - 3. Deposit concrete in horizontal layers of depth not to exceed formwork design pressures and in a manner to avoid inclined construction joints.
  - 4. Consolidate placed concrete with mechanical vibrating equipment in accordance with ACI 301.
    - a. Do not use vibrators to transport concrete inside forms.



- b. Insert and withdraw vibrators vertically at uniformly spaced locations to rapidly penetrate placed layer and at least 6 inches into preceding layer.
  - c. Do not insert vibrators into lower layers of concrete that have begun to lose plasticity.
  - d. At each insertion, limit duration of vibration to time necessary to consolidate concrete, and complete embedment of reinforcement and other embedded items without causing mixture constituents to segregate.
- E. Deposit and consolidate concrete for floors and slabs in a continuous operation, within limits of construction joints, until placement of a panel or section is complete.
- 1. Do not place concrete floors and slabs in a checkerboard sequence.
  - 2. Consolidate concrete during placement operations, so concrete is thoroughly worked around reinforcement and other embedded items and into corners.
  - 3. Maintain reinforcement in position on chairs during concrete placement.
  - 4. Screed slab surfaces with a straightedge and strike off to correct elevations.
  - 5. Level concrete, cut high areas, and fill low areas.
  - 6. Slope surfaces uniformly to drains where required.
  - 7. Begin initial floating using bull floats or darbies to form a uniform and open-textured surface plane, before excess bleedwater appears on the surface.
  - 8. Do not further disturb slab surfaces before starting finishing operations.

### 3.5 FINISHING FORMED SURFACES

A. As-Cast Surface Finishes:

- 1. Finish as noted in Drawings.

B. Related Unformed Surfaces:

- 1. At tops of walls, horizontal offsets, and similar unformed surfaces adjacent to formed surfaces, strike off smooth and finish with a color and texture matching adjacent formed surfaces.
- 2. Continue final surface treatment of formed surfaces uniformly across adjacent unformed surfaces unless otherwise indicated.

### 3.6 FINISHING FLOORS AND SLABS

A. Comply with ACI 302.1R recommendations for screeding, re-straightening, and finishing operations for concrete surfaces. Do not wet concrete surfaces.

B. Trowel Finish:

- 1. After applying float finish, apply first troweling and consolidate concrete by hand or power-driven trowel.
- 2. Continue troweling passes and re-straighten until surface is free of trowel marks and uniform in texture and appearance.
- 3. Grind smooth any surface defects that would telegraph through applied coatings or floor coverings.

4. Do not add water to concrete surface.
5. Do not apply hard-troweled finish to concrete, which has a total air content greater than 3 percent.
6. Apply a trowel finish to surfaces exposed to view.

C. Broom Finish: Apply a broom finish to exterior concrete platforms, steps, ramps, and locations indicated on Drawings.

1. Immediately after float finishing, slightly roughen trafficked surface by brooming with fiber-bristle broom perpendicular to main traffic route.
2. Coordinate required final finish with Architect before application.

### 3.7 INSTALLATION OF MISCELLANEOUS CONCRETE ITEMS

A. Filling In:

1. Fill in holes and openings left in concrete structures after Work of other trades is in place unless otherwise indicated.
2. Mix, place, and cure concrete, as specified, to blend with in-place construction.
3. Provide other miscellaneous concrete filling indicated or required to complete the Work.

B. Curbs: Provide monolithic finish to interior curbs by stripping forms while concrete is still green and by steel-troweling surfaces to a hard, dense finish with corners, intersections, and terminations slightly rounded.

### 3.8 CONCRETE CURING

A. Protect freshly placed concrete from premature drying and excessive cold or hot temperatures.

1. Comply with ACI 301 and ACI 306.1 for cold weather protection during curing.
2. Comply with ACI 301 and ACI 305.1 for hot-weather protection during curing.

B. Curing Formed Surfaces: Comply with ACI 308.1 as follows:

1. Cure formed concrete surfaces, including underside of beams, supported slabs, and other similar surfaces.
2. Cure concrete containing color pigments in accordance with color pigment manufacturer's instructions.
3. If forms remain during curing period, moist cure after loosening forms.
4. If removing forms before end of curing period, continue curing for remainder of curing period, as follows:
  - a. Continuous Fogging: Maintain standing water on concrete surface until final setting of concrete.
  - b. Continuous Sprinkling: Maintain concrete surface continuously wet.

- c. Absorptive Cover: Pre-dampen absorptive material before application; apply additional water to absorptive material to maintain concrete surface continuously wet.
  - d. Water-Retention Sheeting Materials: Cover exposed concrete surfaces with sheeting material, taping, or lapping seams.
  - e. Membrane-Forming Curing Compound: Apply uniformly in continuous operation by power spray or roller in accordance with manufacturer's written instructions.
    - 1) Recoat areas subject to heavy rainfall within three hours after initial application.
    - 2) Maintain continuity of coating and repair damage during curing period.
- C. Curing Unformed Surfaces: Comply with ACI 308.1 as follows:
- 1. Begin curing immediately after finishing concrete.
  - 2. Interior Concrete Floors:
    - a. Floors to Receive Urethane Flooring:
      - 1) As soon as concrete has sufficient set to permit application without marring concrete surface, install prewetted absorptive cover over entire area of floor.
      - 2) Rewet absorptive cover, and cover immediately with polyethylene moisture-retaining cover with edges lapped 6 inches and sealed in place.
      - 3) Secure polyethylene moisture-retaining cover in place to prohibit air from circulating under polyethylene moisture-retaining cover.
      - 4) Leave absorptive cover and polyethylene moisture-retaining cover in place for duration of curing period, but not less than 28 days.
    - b. Floors to Receive Curing and Sealing Compound:
      - 1) Apply uniformly to floors and slabs indicated in a continuous operation by power spray or roller in accordance with manufacturer's written instructions.
      - 2) Recoat areas subjected to heavy rainfall within three hours after initial application.
      - 3) Repeat process 24 hours later, and apply a second coat. Maintain continuity of coating, and repair damage during curing period.

### 3.9 TOLERANCES

- A. Conform to ACI 117.

3.10 FIELD QUALITY CONTROL

- A. Special Inspections: Owner will engage a special inspector to perform field tests and inspections and prepare testing and inspection reports.
1. Testing agency shall be responsible for providing curing container for composite samples on Site and verifying that field-cured composite samples are cured in accordance with ASTM C31/C31M.
  2. Testing agency shall immediately report to Architect, Contractor, and concrete manufacturer any failure of Work to comply with Contract Documents.
  3. Testing agency shall report results of tests and inspections, in writing, to Owner, Architect, Contractor, and concrete manufacturer within 48 hours of inspections and tests.
    - a. Test reports shall include reporting requirements of ASTM C31/C31M, ASTM C39/C39M, and ACI 301, including the following as applicable to each test and inspection:
      - 1) Project name.
      - 2) Name of testing agency.
      - 3) Names and certification numbers of field and laboratory technicians performing inspections and testing.
      - 4) Name of concrete manufacturer.
      - 5) Date and time of inspection, sampling, and field testing.
      - 6) Date and time of concrete placement.
      - 7) Location in Work of concrete represented by samples.
      - 8) Date and time sample was obtained.
      - 9) Truck and batch ticket numbers.
      - 10) Design compressive strength at 28 days.
      - 11) Concrete mixture designation, proportions, and materials.
      - 12) Field test results.
      - 13) Information on storage and curing of samples before testing, including curing method and maximum and minimum temperatures during initial curing period.
      - 14) Type of fracture and compressive break strengths at seven days and 28 days.
- B. Batch Tickets: For each load delivered, submit three copies of batch delivery ticket to testing agency, indicating quantity, mix identification, admixtures, design strength, aggregate size, design air content, design slump at time of batching, and amount of water that can be added at Project site.
- C. Inspections:
1. Batch Plant Inspections: On a random basis, as determined by Architect.
- D. Concrete Tests: Testing of composite samples of fresh concrete obtained in accordance with ASTM C 172/C 172M shall be performed.
- E. Measure floor and slab flatness and levelness in accordance with ASTM E1155 and promptly report test results to Architect.

3.11 PROTECTION

A. Protect concrete surfaces as follows:

1. Protect from petroleum stains.
2. Diaper hydraulic equipment used over concrete surfaces.
3. Prohibit vehicles from interior concrete slabs.
4. Prohibit use of pipe-cutting machinery over concrete surfaces.
5. Prohibit placement of steel items on concrete surfaces.
6. Prohibit use of acids or acidic detergents over concrete surfaces.
7. Protect liquid floor treatment from damage and wear during the remainder of construction period. Use protective methods and materials, including temporary covering, recommended in writing by liquid floor treatments installer.
8. Protect concrete surfaces scheduled to receive surface hardener or polished concrete finish using Floor Slab Protective Covering.

END OF SECTION 03 30 00

## SECTION 04 20 00 - UNIT MASONRY

### PART 1 - GENERAL

#### 1.1 SUMMARY

##### A. Section Includes:

1. Concrete masonry units.
2. Lintels.
3. Mortar and grout materials.
4. Reinforcement.
5. Ties and anchors.
6. Embedded flashing.
7. Accessories.
8. Mortar and grout mixes.

#### 1.2 PREINSTALLATION MEETINGS

- ##### A. Preinstallation Conference: Conduct conference at Project site.

#### 1.3 ACTION SUBMITTALS

- ##### A. Product Data: For each type of product.
- ##### B. Shop Drawings: For reinforcing steel: Indicate bending, lap lengths, and placement of unit masonry reinforcing bars. Comply with ACI 315R.
- ##### C. Samples: For each type and color of exposed masonry unit and colored mortar.

#### 1.4 INFORMATIONAL SUBMITTALS

- ##### A. Material Certificates: For each type and size of product and for masonry units, include data on material properties.
- ##### B. Mix Designs: For each type of mortar. Include description of type and proportions of ingredients.
1. Include test reports for mortar mixes required to comply with property specification. Test in accordance with ASTM C109/C109M for compressive strength, ASTM C1506 for water retention, and ASTM C91/C91M for air content.
  2. Include test reports, in accordance with ASTM C1019, for grout mixes required to comply with compressive strength requirement.

## 1.5 QUALITY ASSURANCE

- A. Sample Panel Mockups: Build sample panels to verify selections made under Sample submittals and to demonstrate aesthetic effects.
  - 1. Build sample panels for typical exterior wall.

## 1.6 FIELD CONDITIONS

- A. Cold-Weather Requirements: Do not use frozen materials or materials mixed or coated with ice or frost. Do not build on frozen substrates. Remove and replace unit masonry damaged by frost or by freezing conditions. Comply with cold-weather construction requirements contained in TMS 602.
- B. Hot-Weather Requirements: Comply with hot-weather construction requirements contained in TMS 602.

## PART 2 - PRODUCTS

### 2.1 UNIT MASONRY, GENERAL

- A. Masonry Standard: Comply with TMS 602, except as modified by requirements in the Contract Documents.
- B. Defective Units: Referenced masonry unit standards may allow a certain percentage of units to contain chips, cracks, or other defects exceeding limits stated. Do not use units where such defects are exposed in the completed Work.
- C. Fire-Resistance Ratings: Comply with requirements for fire-resistance-rated assembly designs indicated.
  - 1. Where fire-resistance-rated construction is indicated, units shall be listed and labeled by a qualified testing agency acceptable to authorities having jurisdiction.

### 2.2 CONCRETE MASONRY UNITS

- A. Shapes: Provide shapes indicated and as follows, with exposed surfaces matching exposed faces of adjacent units unless otherwise indicated.
  - 1. Provide special shapes for lintels, corners, jambs, sashes, movement joints, headers, bonding, and other special conditions.
- B. CMUs: ASTM C90, normal weight.
  - 1. Unit Compressive Strength: Provide units with minimum average net-area compressive strength of 3050 psi.



## 2.3 LINTELS

- A. Concrete Lintels: Precast or formed-in-place concrete lintels complying with requirements in Section 03 20 00 "Concrete Reinforcing," and with reinforcing bars indicated.
- B. Offset Angle Supports: Steel plate brackets anchored to structure, allowing continuous insulation behind shelf angle supporting veneer. Component and anchor size and spacing engineered by manufacturer.

## 2.4 MORTAR AND GROUT MATERIALS

- A. Portland Cement: ASTM C150/C150M, Type I or II, except Type III may be used for cold-weather construction. Provide natural color or white cement as required to produce mortar color indicated.
- B. Hydrated Lime: ASTM C207, Type S.
- C. Aggregate for Mortar: ASTM C144.
  - 1. For mortar that is exposed to view, use washed aggregate consisting of natural sand or crushed stone.
  - 2. For joints less than 1/4 inch thick, use aggregate graded with 100 percent passing the No. 16 sieve.
  - 3. White-Mortar Aggregates: Natural white sand or crushed white stone.
- D. Water: Potable.

## 2.5 REINFORCEMENT

- A. Uncoated-Steel Reinforcing Bars: ASTM A615/A615M or ASTM A996/A996M, Grade 60.
- B. Masonry-Joint Reinforcement, General: ASTM A951/A951M.
- C. Masonry-Joint Reinforcement for Single-Wythe Masonry: Ladder type with single pair of side rods.
- D. Masonry-Joint Reinforcement for Multi-wythe Masonry:
  - 1. Ladder type with one side rod at each face shell of hollow masonry units more than 4 inches wide, plus two side rods at each wythe of masonry 4 inches wide or less.

## 2.6 TIES AND ANCHORS

- A. General: Ties and anchors shall extend at least 1-1/2 inches into veneer but with at least a 5/8-inch cover on outside face.

- B. Materials: Provide ties and anchors as specified in drawings.

## 2.7 EMBEDDED FLASHING

- A. Metal Flashing: Provide metal flashing complying with SMACNA's "Architectural Sheet Metal Manual".
  1. Stainless Steel: ASTM A240/A240M or ASTM A666, 0.016 inch thick.
  2. Fabricate continuous flashings in sections 96 inches long minimum, but not exceeding 12 ft.. Provide splice plates at joints of formed, smooth metal flashing.
  3. Fabricate metal drip edges from stainless steel. Extend at least 3 inches into wall and 1/2 inch out from wall, with outer edge bent down 30 degrees and hemmed.
  4. Fabricate metal sealant stops from stainless steel. Extend at least 3 inches into wall and out to exterior face of wall. At exterior face of wall, bend metal back on itself for 3/4 inch and down into joint 1/4 inch to form a stop for retaining sealant backer rod.
  5. Fabricate metal expansion-joint strips from stainless steel to shapes indicated.
- B. Adhesives, Primers, and Seam Tapes for Flashings: Flashing manufacturer's standard products or products recommended by flashing manufacturer for bonding flashing sheets to each other and to substrates.

## 2.8 ACCESSORIES

- A. Compressible Filler: Pre-molded filler strips complying with ASTM D1056, Grade 2A1; compressible up to 35 percent; of width and thickness indicated.
- B. Preformed Control-Joint Gaskets: As noted in drawings and designed to fit standard sash block and to maintain lateral stability in masonry wall; size and configuration as indicated.
- C. Bond-Breaker Strips: Asphalt-saturated felt complying with ASTM D226/D226M, Type I (No. 15 asphalt felt).
- D. Weep/Cavity Vents: Use the following unless otherwise indicated:
  1. Cellular Plastic Weep/Vent: One-piece, flexible extrusion made from UV-resistant polypropylene copolymer, full height and width of head joint and depth 1/8 inch less than depth of outer wythe, in color selected from manufacturer's standard.

## 2.9 MORTAR AND GROUT MIXES

- A. General: Do not use admixtures, including pigments, air-entraining agents, accelerators, retarders, water-repellent agents, antifreeze compounds, or other admixtures unless otherwise indicated.
  1. Do not use calcium chloride in mortar or grout.
  2. Use Type "S" mortar unless otherwise indicated.

3. Add cold-weather admixture (if used) at same rate for all mortar that will be exposed to view, regardless of weather conditions, to ensure that mortar color is consistent.
- B. Grout for Unit Masonry: Comply with ASTM C476.
1. Use grout of type indicated or, if not otherwise indicated, of type (fine or coarse) that will comply with TMS 602 for dimensions of grout spaces and pour height.
  2. Proportion grout in accordance with ASTM C476.
  3. Provide grout with a slump as measured in accordance with ASTM C143/C143M.

### PART 3 - EXECUTION

#### 3.1 INSTALLATION, GENERAL

- A. Use full-size units without cutting if possible. If cutting is required to provide a continuous pattern or to fit adjoining construction, cut units with motor-driven saws; provide clean, sharp, unchipped edges. Allow units to dry before laying unless wetting of units is specified. Install cut units with cut surfaces and, where possible, cut edges concealed.
- B. Select and arrange units for exposed unit masonry to produce a uniform blend of colors and textures. Mix units from several pallets or cubes as they are placed.

#### 3.2 TOLERANCES

- A. Dimensions and Locations of Elements:
1. For dimensions in cross section or elevation, do not vary by more than plus 1/2 inch or minus 1/4 inch.
  2. For location of elements in plan, do not vary from that indicated by more than plus or minus 1/2 inch.
  3. For location of elements in elevation, do not vary from that indicated by more than plus or minus 1/4 inch in a story height or 1/2 inch total.
- B. Lines and Levels:
1. For bed joints and top surfaces of bearing walls, do not vary from level by more than 1/4 inch in 10 ft., or 1/2-inch maximum.
  2. For conspicuous horizontal lines, such as lintels, sills, parapets, and reveals, do not vary from level by more than 1/8 inch in 10 ft., 1/4 inch in 20 ft., or 1/2-inch maximum.
  3. For vertical lines and surfaces, do not vary from plumb by more than 1/4 inch in 10 ft., 3/8 inch in 20 ft., or 1/2-inch maximum.
  4. For conspicuous vertical lines, such as external corners, door jambs, reveals, and expansion and control joints, do not vary from plumb by more than 1/8 inch in 10 ft., 1/4 inch in 20 ft., or 1/2-inch maximum.

5. For lines and surfaces, do not vary from straight by more than 1/4 inch in 10 ft., 3/8 inch in 20 ft., or 1/2-inch maximum.
6. For vertical alignment of exposed head joints, do not vary from plumb by more than 1/4 inch in 10 ft. or 1/2-inch maximum.

C. Joints:

1. For bed joints, do not vary from thickness indicated by more than plus or minus 1/8 inch, with a maximum thickness limited to 1/2 inch.
2. For head and collar joints, do not vary from thickness indicated by more than plus 3/8 inch or minus 1/4 inch.
3. For exposed head joints, do not vary from thickness indicated by more than plus or minus 1/8 inch.

### 3.3 LAYING MASONRY WALLS

- A. Lay out walls in advance for accurate spacing of surface bond patterns with uniform joint thicknesses and for accurate location of openings, movement-type joints, returns, and offsets. Avoid using less-than-half-size units, particularly at corners, jambs, and, where possible, at other locations.
- B. Bond Pattern for Exposed Masonry: Unless otherwise indicated, lay exposed masonry in running bond; do not use units with less-than-nominal 4-inch horizontal face dimensions at corners or jambs.
- C. Built-in Work: As construction progresses, build in items specified in this and other Sections. Fill in solidly with masonry around built-in items.
- D. Fill space between steel frames and masonry solidly with mortar unless otherwise indicated.
- E. Fill cores in hollow CMUs with grout 24 inches under bearing plates, beams, lintels, posts, and similar items unless otherwise indicated.

### 3.4 MORTAR BEDDING AND JOINTING

- A. Lay CMUs as follows:
  1. Bed face shells in mortar and make head joints of depth equal to bed joints.
  2. Bed webs in mortar in all courses of piers, columns, and pilasters.
  3. Bed webs in mortar in grouted masonry, including starting course on footings.
  4. Fully bed entire units, including areas under cells, at starting course on footings where cells are not grouted.
  5. Fully bed units and fill cells with mortar at anchors and ties as needed to fully embed anchors and ties in mortar.
- B. Rake out mortar joints at pre-faced CMUs to a uniform depth of 1/4 inch and point with epoxy mortar to comply with epoxy-mortar manufacturer's written instructions.

- C. Tool exposed joints slightly concave when thumbprint hard, using a jointer larger than joint thickness unless otherwise indicated.
- D. Cut joints flush for masonry walls to receive plaster or other direct-applied finishes (other than paint) unless otherwise indicated.

### 3.5 ANCHORED MASONRY VENEERS

- A. Anchor masonry veneers to wall framing with masonry-veneer anchors to comply with the following requirements:
  - 1. Fasten anchors through sheathing to wall framing with metal fasteners of type indicated. Use two fasteners unless anchor design only uses one fastener.
  - 2. Embed tie sections in masonry joints.
  - 3. Locate anchor sections to allow maximum vertical differential movement of ties up and down.
  - 4. Space anchors as indicated, but not more than 18 inches o.c. vertically and 24 inches o.c. horizontally, with not less than one anchor for each 2 sq. ft. of wall area. Install additional anchors within 12 inches of openings and at intervals, not exceeding 8 inches, around perimeter.

### 3.6 MASONRY-CELL FILL

- A. Pour fill into cavities to fill void spaces. Maintain inspection ports to show presence of fill at extremities of each pour area. Close the ports after filling has been confirmed. Limit the fall of fill to one story high, but not more than 20 ft.

### 3.7 MASONRY-JOINT REINFORCEMENT

- A. General: Install entire length of longitudinal side rods in mortar with a minimum cover of 5/8 inch on exterior side of walls, 1/2 inch elsewhere. Lap reinforcement a minimum of 6 inches.
- B. Interrupt joint reinforcement at control and expansion joints unless otherwise indicated.
- C. Provide continuity at corners by using prefabricated L-shaped units.

### 3.8 ANCHORING MASONRY TO STRUCTURAL STEEL AND CONCRETE

- A. Anchor masonry to structural steel and concrete, where masonry abuts or faces structural steel or concrete, to comply with the following:
  - 1. Provide an open space as indicated in drawings between masonry and structural steel or concrete unless otherwise indicated. Keep open space free of mortar and other rigid materials.
  - 2. Anchor masonry with anchors embedded in masonry joints and attached to structure.

3. Space anchors as indicated, but not more than 24 inches o.c. vertically and 36 inches o.c. horizontally.

### 3.9 FLASHING, WEEP HOLES, AND CAVITY VENTS

- A. General: Install embedded flashing and weep holes in masonry at shelf angles, lintels, ledges, other obstructions to downward flow of water in wall, and where indicated
- B. Install flashing as follows unless otherwise indicated:
  1. Prepare masonry surfaces so they are smooth and free from projections that could puncture flashing. Where flashing is within mortar joint, place through-wall flashing on sloping bed of mortar and cover with mortar. Before covering with mortar, seal penetrations in flashing with adhesive, sealant, or tape as recommended by flashing manufacturer.
- C. Install single-wythe CMU flashing system in bed joints of CMU walls where indicated to comply with manufacturer's written instructions. Install CMU cell pans with upturned edges located below face shells and webs of CMUs above and with weep spouts aligned with face of wall. Install CMU web covers so that they cover upturned edges of CMU cell pans at CMU webs and extend from face shell to face shell.
- D. Install weep holes in exterior wythes and veneers in head joints of first course of masonry immediately above embedded flashing.
  1. Use specified weep/cavity vent products to form weep holes.
  2. Space weep holes 24 inches o.c. unless otherwise indicated.
  3. Cover cavity side of weep holes with plastic insect screening at cavities insulated with loose-fill insulation.
- E. Place cavity drainage material in cavities to comply with configuration requirements for cavity drainage material in "Accessories" Article.
- F. Install cavity vents in head joints in exterior wythes at spacing indicated..
  1. Close cavities off vertically and horizontally with blocking in manner indicated. Install through-wall flashing and weep holes above horizontal blocking.

### 3.10 REINFORCED UNIT MASONRY

- A. Temporary Formwork and Shores: Construct formwork and shores as needed to support reinforced masonry elements during construction.
  1. Construct formwork to provide shape, line, and dimensions of completed masonry as indicated. Make forms sufficiently tight to prevent leakage of mortar and grout. Brace, tie, and support forms to maintain position and shape during construction and curing of reinforced masonry.

2. Do not remove forms and shores until reinforced masonry members have hardened sufficiently to carry their own weight and that of other loads that may be placed on them during construction.

B. Placing Reinforcement: Comply with requirements in TMS 602.

C. Grouting: Do not place grout until entire height of masonry to be grouted has attained enough strength to resist grout pressure.

1. Comply with requirements in TMS 602 for cleanouts and for grout placement, including minimum grout space and maximum pour height.

### 3.11 FIELD QUALITY CONTROL

A. Testing Agency: Engage a qualified testing agency to perform tests and inspections. Allow inspectors access to scaffolding and work areas as needed to perform tests and inspections. Retesting of materials that fail to comply with specified requirements will be at Contractor's expense.

B. Inspections: Special inspections in accordance with Level 2 in TMS 402.

C. Testing Prior to Construction: One set of tests.

D. Concrete Masonry Unit Test: For each type of unit provided, in accordance with ASTM C140/C140M for compressive strength.

E. Mortar Aggregate Ratio Test (Proportion Specification): For each mix provided, in accordance with ASTM C780.

### 3.12 CLEANING

A. In-Progress Cleaning: Clean unit masonry as work progresses by dry brushing to remove mortar fins and smears before tooling joints.

B. Final Cleaning: After mortar is thoroughly set and cured, clean exposed masonry as follows:

1. Remove large mortar particles by hand with wooden paddles and nonmetallic scrape hoes or chisels.
2. Test cleaning methods on sample wall panel; leave one-half of panel uncleaned for comparison purposes. Obtain Architect's approval of sample cleaning before proceeding with cleaning of masonry.
3. Clean concrete masonry by applicable cleaning methods indicated in NCMA TEK 8-4A.
4. Clean masonry with a proprietary acidic masonry cleaner applied according to manufacturer's written instructions.



3.13 MASONRY WASTE DISPOSAL

- A. Waste Disposal as Fill Material: Dispose of clean masonry waste, including excess or soil-contaminated sand, waste mortar, and broken masonry units, by crushing and mixing with fill material as fill is placed.
  - 1. Do not dispose of masonry waste as fill within 18 inches of finished grade.
- B. Masonry Waste Recycling: Return broken CMUs not used as fill to manufacturer for recycling.
- C. Excess Masonry Waste: Remove excess clean masonry waste that cannot be used as fill, as described above or recycled, and other masonry waste, and legally dispose of off Owner's property.

END OF SECTION 04 20 00

## SECTION 05 40 00 - COLD-FORMED METAL FRAMING

### PART 1 - GENERAL

#### 1.1 SUMMARY

A. Section Includes:

1. Interior non-load-bearing wall framing.

#### 1.2 PREINSTALLATION MEETINGS

- A. Preinstallation Conference: Conduct conference at Project site.

#### 1.3 ACTION SUBMITTALS

A. Product Data: For the following:

1. Cold-formed steel framing materials.
2. Interior non-load-bearing wall framing.
3. Vertical deflection clips.
4. Single deflection track.
5. Drift clips.
6. Post-installed anchors.
7. Power-actuated anchors.

B. Shop Drawings:

1. Include layout, spacings, sizes, thicknesses, and types of cold-formed steel framing; fabrication; and fastening and anchorage details, including mechanical fasteners.
2. Indicate reinforcing channels, opening framing, supplemental framing, strapping, bracing, bridging, splices, accessories, connection details, and attachment to adjoining work.

#### 1.4 INFORMATIONAL SUBMITTALS

- A. Welding certificates.
- B. Product certificates.
- C. Product test reports.
- D. Research Reports:

1. For post-installed anchors and power-actuated fasteners, from ICC-ES or other qualified testing agency acceptable to authorities having jurisdiction.

## 1.5 QUALITY ASSURANCE

- A. Testing Agency Qualifications: Qualified according to ASTM E329 for testing indicated.
- B. Product Tests: Mill certificates or data from a qualified independent testing agency.
- C. Welding Qualifications: Qualify procedures and personnel according to the following:
  1. AWS D1.1/D1.1M, "Structural Welding Code - Steel."
  2. AWS D1.3/D1.3M, "Structural Welding Code - Sheet Steel."

## PART 2 - PRODUCTS

### 2.1 PERFORMANCE REQUIREMENTS

- A. Cold-Formed Steel Framing Standards: Unless more stringent requirements are indicated, framing shall comply with AISI S100, AISI S200, and the following:
  1. Wall Studs: AISI S211.
  2. Headers: AISI S212.
  3. Lateral Design: AISI S213.

### 2.2 COLD-FORMED STEEL FRAMING MATERIALS

- A. Steel Sheet: ASTM A1003/A1003M, Structural Grade, Type H, metallic coated, of grade and coating designation as follows:
  1. Grade and Coating: As required by structural performance.
- B. Steel Sheet for Vertical Deflection, Drift Clips: ASTM A653/A653M, structural steel, zinc coated, of grade and coating as follows:
  1. Grade and Coating: As required by structural performance.

### 2.3 INTERIOR NON-LOAD-BEARING WALL FRAMING

- A. Steel Studs: Manufacturer's standard C-shaped steel studs, of web depths indicated, punched, with stiffened flanges.
- B. Steel Track: Manufacturer's standard U-shaped steel track, of web depths indicated, unpunched, with unstiffened flanges, and matching minimum base-metal thickness of steel studs.

- C. Vertical Deflection Clips: Manufacturer's standard clips, capable of accommodating upward and downward vertical displacement of primary structure through positive mechanical attachment to stud web.
- D. Single Deflection Track: Manufacturer's single, deep-leg, U-shaped steel track; unpunched, with unstiffened flanges, of web depth to contain studs while allowing free vertical movement, with flanges designed to support horizontal loads and transfer them to the primary structure.
- E. Drift Clips: Manufacturer's standard bypass or head clips, capable of isolating wall stud from upward and downward vertical displacement and lateral drift of primary structure through positive mechanical attachment to stud web and structure.

#### 2.4 FRAMING ACCESSORIES

- A. Fabricate steel-framing accessories from ASTM A1003/A1003M, Structural Grade, Type H, metallic coated steel sheet, of same grade and coating designation used for framing members.
- B. Provide accessories of manufacturer's standard thickness and configuration, unless otherwise indicated.

#### 2.5 ANCHORS, CLIPS, AND FASTENERS

- A. Steel Shapes and Clips: ASTM A36/A36M, zinc coated by hot-dip process according to ASTM A123/A123M.
- B. Anchor Bolts: ASTM F1554, threaded carbon-steel bolts, carbon-steel nuts, and flat, hardened-steel washers; zinc coated by hot-dip process according to ASTM A153/A153M, Class C.
- C. Post-Installed Anchors: Fastener systems with bolts of same basic metal as fastened metal, if visible, unless otherwise indicated; with working capacity greater than or equal to the design load, according to an evaluation report acceptable to authorities having jurisdiction, based on ICC-ES AC193 as appropriate for the substrate.
  - 1. Uses: Securing cold-formed steel framing to structure.
  - 2. Material for Interior Locations: Carbon-steel components zinc plated to comply with ASTM B633 or ASTM F1941, Class Fe/Zn 5, unless otherwise indicated.
  - 3. Material for Exterior or Interior Locations and Where Stainless Steel Is Indicated: Alloy Group 1 stainless-steel bolts, ASTM F593, and nuts, ASTM F594.
- D. Power-Actuated Anchors: Fastener systems with working capacity greater than or equal to the design load, according to an evaluation report acceptable to authorities having jurisdiction, based on ICC-ES AC70.
- E. Mechanical Fasteners: ASTM C1513, corrosion-resistant-coated, self-drilling, self-tapping, steel drill screws.

1. Head Type: Low-profile head beneath sheathing; manufacturer's standard elsewhere.

## 2.6 MISCELLANEOUS MATERIALS

- A. Galvanizing Repair Paint: ASTM A780/A780M.
- B. Cement Grout: Portland cement, ASTM C150/C150M, Type I; and clean, natural sand, ASTM C404. Mix at ratio of 1 part cement to 2-1/2 parts sand, by volume, with minimum water required for placement and hydration.
- C. Nonmetallic, Non-shrink Grout: Factory-packaged, nonmetallic, noncorrosive, non-staining grout, complying with ASTM C1107/C1107M, and with a fluid consistency and 30-minute working time.
- D. Shims: Load-bearing, high-density, multi-monomer, non-leaching plastic; or cold-formed steel of same grade and metallic coating as framing members supported by shims.
- E. Sill Sealer Gasket: Closed-cell neoprene foam, 1/4 inch thick, selected from manufacturer's standard widths to match width of bottom track or rim track members as required.

## PART 3 - EXECUTION

### 3.1 INSTALLATION, GENERAL

- A. Cold-formed steel framing may be shop or field fabricated for installation, or it may be field assembled.
- B. Install cold-formed steel framing according to AISI S200, AISI S202, and manufacturer's written instructions unless more stringent requirements are indicated.
- C. Install cold-formed steel framing and accessories plumb, square, and true to line, and with connections securely fastened.
- D. Install framing members in one-piece lengths unless splice connections are indicated for track or tension members.
- E. Install temporary bracing and supports to secure framing and support loads equal to those for which structure was designed. Maintain braces and supports in place, undisturbed, until entire integrated supporting structure has been completed and permanent connections to framing are secured.
- F. Do not bridge building expansion joints with cold-formed steel framing. Independently frame both sides of joints.

- G. Install insulation, specified in Section 07 21 00 "Thermal Insulation," in framing-assembly members, such as headers, sills, boxed joists, and multiple studs at openings, that are inaccessible on completion of framing work.
- H. Fasten hole-reinforcing plate over web penetrations that exceed size of manufacturer's approved or standard punched openings.

### 3.2 INSTALLATION OF INTERIOR NON-LOAD-BEARING WALL FRAMING

- A. Install continuous tracks sized to match studs. Align tracks accurately and securely anchor to supporting structure.
- B. Fasten both flanges of studs to top and bottom track unless otherwise indicated. Space studs as follows:
  - 1. Stud Spacing: As indicated on Drawings.
- C. Set studs plumb, except as needed for diagonal bracing or required for non-plumb walls or warped surfaces and similar requirements.
- D. Isolate non-load-bearing steel framing from building structure to prevent transfer of vertical loads while providing lateral support.
  - 1. Install single deep-leg deflection tracks and anchor to building structure.
  - 2. Connect vertical deflection clips to studs and anchor to building structure.
  - 3. Connect drift clips to cold-formed steel metal framing and anchor to building structure.
- E. Install horizontal bridging in wall studs, spaced vertically in rows indicated but not more than 48 inches apart. Fasten at each stud intersection.
- F. Install miscellaneous framing and connections, including stud kickers, web stiffeners, clip angles, continuous angles, anchors, and fasteners, to provide a complete and stable wall-framing system.

### 3.3 INSTALLATION TOLERANCES

- A. Install cold-formed steel framing level, plumb, and true to line to a maximum allowable tolerance variation of 1/8 inch in 10 feet and as follows:
  - 1. Space individual framing members no more than plus or minus 1/8 inch from plan location. Cumulative error shall not exceed minimum fastening requirements of sheathing or other finishing materials.

### 3.4 REPAIRS

- A. Galvanizing Repairs: Prepare and repair damaged galvanized coatings on fabricated and installed cold-formed steel framing with galvanized repair paint according to ASTM A780/A780M and manufacturer's written instructions.

3.5 FIELD QUALITY CONTROL

- A. Testing: Owner will engage a qualified independent testing and inspecting agency to perform field tests and inspections and prepare test reports.
- B. Field and shop welds will be subject to testing and inspecting.
- C. Testing agency will report test results promptly and in writing to Contractor and Architect.
- D. Cold-formed steel framing will be considered defective if it does not pass tests and inspections.
- E. Additional testing and inspecting, at Contractor's expense, will be performed to determine compliance of replaced or additional work with specified requirements.

END OF SECTION 05 40 00



## SECTION 05 50 00 - METAL FABRICATIONS

### PART 1 - GENERAL

#### 1.1 SUMMARY

- A. Section Includes:
  - 1. Metal bollards.

#### 1.2 ACTION SUBMITTALS

- A. Product Data: For the following:
  - 1. Metal bollards.
- B. Shop Drawings: Show fabrication and installation details.

### PART 2 - PRODUCTS

#### 2.1 METALS

- A. Metal Surfaces, General: Provide materials with smooth, flat surfaces unless otherwise indicated. For metal fabrications exposed to view in the completed Work, provide materials without seam marks, roller marks, rolled trade names, or blemishes.
- B. Steel Pipe: ASTM A53/A53M, Standard Weight (Schedule 40) unless otherwise indicated.

#### 2.2 FASTENERS

- A. General: Unless otherwise indicated, provide Type 316 stainless steel fasteners for exterior use and zinc-plated fasteners with coating complying with ASTM B633 or ASTM F1941/F1941M, Class Fe/Zn 5, at exterior walls. Select fasteners for type, grade, and class required.
- B. Cast-in-Place Anchors in Concrete: Either threaded or wedge type unless otherwise indicated; galvanized ferrous castings, either ASTM A47/A47M malleable iron or ASTM A27/A27M cast steel. Provide bolts, washers, and shims as needed, all hot-dip galvanized per ASTM F2329/F2329M.
- C. Post-Installed Anchors: Torque-controlled expansion anchors.

## 2.3 MISCELLANEOUS MATERIALS

- A. Shop Primers: Provide primers that comply with Section 09 91 00 "Painting".
- B. Concrete: Comply with requirements in Section 03 30 00 "Cast-in-Place Concrete" for normal-weight, air-entrained concrete with a minimum 28-day compressive strength of 3000 psi

## 2.4 FABRICATION, GENERAL

- A. Shop Assembly: Preassemble items in the shop to greatest extent possible. Disassemble units only as necessary for shipping and handling limitations. Use connections that maintain structural value of joined pieces. Clearly mark units for reassembly and coordinated installation.
- B. Cut, drill, and punch metals cleanly and accurately. Remove burrs and ease edges to a radius of approximately 1/32 inch unless otherwise indicated. Remove sharp or rough areas on exposed surfaces.
- C. Where units are indicated to be cast into concrete or built into masonry, equip with integrally welded steel strap anchors, not less than 8 inches from ends and corners of units and 24 inches o.c.

## 2.5 METAL BOLLARDS

- A. Fabricate metal bollards from Schedule 80 steel pipe.
- B. Fabricate sleeves for bollard anchorage from steel or stainless steel pipe with 1/4-inch-thick, steel or stainless steel plate welded to bottom of sleeve. Make sleeves not less than 8 inches deep and 3/4 inch larger than OD of bollard.
- C. Prime steel bollards with primer specified in Section 09 91 00 "Painting".

## 2.6 GENERAL FINISH REQUIREMENTS

- A. Finish metal fabrications after assembly.

# PART 3 - EXECUTION

## 3.1 INSTALLATION, GENERAL

- A. Cutting, Fitting, and Placement: Perform cutting, drilling, and fitting required for installing metal fabrications. Set metal fabrications accurately in location, alignment, and elevation; with edges and surfaces level, plumb, true, and free of rack; and measured from established lines and levels.

- B. Fastening to In-Place Construction: Provide anchorage devices and fasteners where metal fabrications are required to be fastened to in-place construction. Provide threaded fasteners for use with concrete and masonry inserts, toggle bolts, through bolts, lag screws, wood screws, and other connectors.
- C. Provide temporary bracing or anchors in formwork for items that are to be built into concrete, masonry, or similar construction.

### 3.2 INSTALLATION OF METAL BOLLARDS

- A. Fill metal-capped bollards solidly with concrete and allow concrete to cure seven days before installing.
- B. Anchor bollards in concrete **with pipe sleeves preset and anchored into concrete**. Fill annular space around bollard solidly with shrinkage-resistant grout; mixed and placed to comply with grout manufacturer's written instructions. Slope grout up approximately 1/8 inch toward bollard.
- C. Fill bollards solidly with concrete, mounding top surface to shed water.

### 3.3 REPAIRS

- A. Touchup Painting:
  - 1. Immediately after erection, clean field welds, bolted connections, and abraded areas. Paint uncoated and abraded areas with same material as used for shop painting to comply with SSPC-PA 1 for touching up shop-painted surfaces.
- B. Galvanized Surfaces: Clean field welds, bolted connections, and abraded areas and repair galvanizing to comply with ASTM A780/A780M.

END OF SECTION 05 50 00

## SECTION 05 51 19 - METAL GRATING STAIRS

### PART 1 - GENERAL

#### 1.1 SUMMARY

A. Section Includes:

1. Industrial Class stairs with steel-grating treads.
2. Steel railings and guards attached to metal stairs.

#### 1.2 COORDINATION

- A. Coordinate selection of shop primers with topcoats to be applied over them. Comply with paint and coating manufacturers' written instructions to ensure that shop primers and topcoats are compatible with one another.

#### 1.3 ACTION SUBMITTALS

A. Product Data: For metal grating stairs and the following:

1. Gratings.
2. Woven-wire mesh.
3. Welded-wire mesh.
4. Shop primer products.
5. Grout.

B. Shop Drawings:

1. Include plans, elevations, sections, details, and attachment to other work.
2. Indicate sizes of metal sections, thickness of metals, profiles, holes, and field joints.
3. Include plan at each level.
4. Indicate locations of anchors, weld plates, and blocking for attachment of wall-mounted handrails.

- C. Delegated-Design Submittal: For stairs, railings, and guards, including analysis data signed and sealed by the qualified professional engineer responsible for their preparation.

#### 1.4 INFORMATIONAL SUBMITTALS

- A. Qualification Data: For professional engineer's experience with providing delegated-design engineering services of the kind indicated, including documentation that engineer is licensed in the jurisdiction in which Project is located.

- B. Welding certificates.

## 1.5 QUALITY ASSURANCE

- A. Installer Qualifications: Fabricator of products.
- B. Welding Qualifications: Qualify procedures and personnel according to AWS D1.1/D1.1M, "Structural Welding Code - Steel."

## PART 2 - PRODUCTS

### 2.1 PERFORMANCE REQUIREMENTS

- A. Structural Performance of Stairs: Metal stairs shall withstand the effects of gravity loads and the following loads and stresses within limits and under conditions indicated:
  - 1. Uniform Load: 100 lbf/sq. ft.
  - 2. Concentrated Load: 300 lbf applied on an area of 4 sq. in.
  - 3. Uniform and concentrated loads need not be assumed to act concurrently.
  - 4. Stair Framing: Capable of withstanding stresses resulting from railing and guard loads in addition to loads specified above.
  - 5. Limit deflection of treads, platforms, and framing members to L/360.
- B. Structural Performance of Railings and Guards: Railings and guards, including attachment to building construction, shall withstand the effects of gravity loads and the following loads and stresses within limits and under conditions indicated:
  - 1. Handrails and Top Rails of Guards:
    - a. Uniform load of 50 lbf/ft. applied in any direction.
    - b. Concentrated load of 200 lbf applied in any direction.
    - c. Uniform and concentrated loads need not be assumed to act concurrently.
  - 2. Infill of Guards:
    - a. Concentrated load of 50 lbf applied horizontally on an area of 1 sq. ft..
    - b. Infill load and other loads need not be assumed to act concurrently.

### 2.2 METALS

- A. Steel Plates, Shapes, and Bars: ASTM A36/A36M.
- B. Rolled-Steel Floor Plate: ASTM A786/A786M, rolled from plate complying with ASTM A36/A36M or ASTM A283/A283M, Grade C or D.
- C. Steel Bars for Grating Treads: ASTM A36/A36M or steel strip, ASTM A1011/A1011M or ASTM A1018/A1018M.

- D. Steel Wire Rod for Grating Crossbars: ASTM A510/A510M.
- E. Aluminum Bars for Grating Treads: ASTM B221 extruded aluminum, alloys as follows:
  - 1. 6061-T6 or 6063-T6, for bearing bars of gratings and shapes.
  - 2. 6061-T1, for grating crossbars.
- F. Steel Tubing for Railings and Guards: ASTM A513/A513M.
- G. Welded-Wire Mesh: diamond pattern, 2-inch welded-wire mesh, made from 0.236-inch nominal-diameter steel wire complying with ASTM A510/A510M.

## 2.3 FASTENERS

- A. Select fasteners for type, grade, and class required.
- B. Fasteners for Anchoring Railings and Guards to Other Construction: Select fasteners of type, grade, and class required to produce connections suitable for anchoring railings and guards to other types of construction indicated and capable of withstanding design loads.
- C. Post-Installed Anchors: Anchors capable of sustaining, without failure, a load equal to six times the load imposed when installed in unit masonry and four times the load imposed when installed in concrete, as determined by testing according to ASTM E488/E488M, conducted by a qualified independent testing agency.
  - 1. Material for Interior Locations: Carbon-steel components zinc plated to comply with ASTM B633 or ASTM F1941/F1941M, Class Fe/Zn 5, unless otherwise indicated.
  - 2. Material for Exterior Locations and Where Stainless Steel Is Indicated: Alloy Group 1 stainless-steel bolts, ASTM F593, and nuts, ASTM F594.

## 2.4 MISCELLANEOUS MATERIALS

- A. Shop Primers: Provide primers that comply with Section 09 91 23 "Interior Painting".
- B. Universal Shop Primer: Fast-curing, lead- and chromate-free, universal modified-alkyd primer complying with MPI#79 and compatible with topcoat.
  - 1. Use primer containing pigments that make it easily distinguishable from zinc-rich primer.
- C. Shop Primer for Galvanized Steel: Primer formulated for exterior use over zinc-coated metal and compatible with finish paint systems indicated.
- D. Galvanizing Repair Paint: High-zinc-dust-content paint complying with ASTM A780/A780M and compatible with paints specified to be used over it.

## 2.5 FABRICATION, GENERAL

- A. Provide complete stair assemblies, including metal framing, hangers, railings, guards, clips, brackets, bearing plates, and other components necessary to support and anchor stairs and platforms on supporting structure.
  - 1. Join components by welding unless otherwise indicated.
  - 2. Use connections that maintain structural value of joined pieces.
- B. Assemble stairs, railings, and guards in shop to greatest extent possible.
  - 1. Disassemble units only as necessary for shipping and handling limitations.
  - 2. Clearly mark units for reassembly and coordinated installation.
- C. Cut, drill, and punch metals cleanly and accurately.
  - 1. Remove burrs and ease edges to a radius of approximately 1/32 inch unless otherwise indicated.
  - 2. Remove sharp or rough areas on exposed surfaces.
- D. Form bent-metal corners to smallest radius possible without causing grain separation or otherwise impairing work.
- E. Form exposed work with accurate angles and surfaces and straight edges.
- F. Weld connections to comply with the following:
  - 1. Use materials and methods that minimize distortion and develop strength and corrosion resistance of base metals.
  - 2. Obtain fusion without undercut or overlap.
  - 3. Remove welding flux immediately.
  - 4. At exposed connections, finish exposed welds to comply with NOMMA's "Voluntary Joint Finish Standards" for Finish # 3 - Partially dressed weld with spatter removed.
- G. Form exposed connections with hairline joints, flush and smooth, using concealed fasteners where possible.
  - 1. Where exposed fasteners are required, use Phillips flat-head (countersunk) screws or bolts unless otherwise indicated.
  - 2. Locate joints where least conspicuous.
  - 3. Fabricate joints that are exposed to weather in a manner to exclude water.
  - 4. Provide weep holes where water may accumulate internally.

## 2.6 FABRICATION OF STEEL-FRAMED STAIRS

- A. NAAMM Stair Standard: Comply with NAAMM AMP 510, "Metal Stairs Manual," for Industrial Class, unless more stringent requirements are indicated.
- B. Stair Framing:



1. Fabricate stringers of steel plates or channels.
    - a. Stringer Size: As required to comply with "Performance Requirements" Article.
    - b. Provide closures for exposed ends of channel stringers.
  2. Construct platforms and tread supports of steel plate or channel headers and miscellaneous framing members as required to comply with "Performance Requirements" Article.
    - a. Provide closures for exposed ends of channel framing.
  3. Weld stringers to headers; weld framing members to stringers and headers.
  4. Where stairs are enclosed by shaft-wall assemblies, provide hanger rods or struts to support landings from floor construction above or below.
    - a. Locate hanger rods and struts where they do not encroach on required stair width and are within the fire-resistance-rated stair enclosure.
  5. Where masonry walls support metal stairs, provide temporary supporting struts designed for erecting steel stair components before installing masonry.
- C. Metal Bar-Grating Stairs: Form treads and platforms to configurations shown from metal bar grating; fabricate to comply with NAAMM MBG 531, "Metal Bar Grating Manual."
- D. Risers: Open.
- E. Toe Plates: Provide toe plates around openings and at edge of open-sided floors and platforms, and at open ends and open back edges of treads.
1. Material and Finish: Steel plate to match finish of other steel items.
  2. Fabricate to dimensions and details indicated.

## 2.7 FABRICATION OF STAIR RAILINGS AND GUARDS

- A. Fabricate railings and guards to comply with requirements indicated for design, dimensions, details, finish, and member sizes, including wall thickness of member, post spacings, wall bracket spacing, and anchorage, but not less than that needed to withstand indicated loads.
1. Rails and Posts: 1-1/2-inch-square top and bottom rails and 1-1/2-inch-square posts.
  2. Intermediate Rails Infill: 1-1/2-inch-square intermediate rails spaced per IBC.
- B. Welded Connections: Fabricate railings and guards with welded connections.
1. Fabricate connections that are exposed to weather in a manner that excludes water.
    - a. Provide weep holes where water may accumulate internally.

2. Cope components at connections to provide close fit, or use fittings designed for this purpose.
  3. Weld all around at connections, including at fittings.
  4. Use materials and methods that minimize distortion and develop strength and corrosion resistance of base metals.
  5. Obtain fusion without undercut or overlap.
  6. Remove flux immediately.
  7. Finish welds to comply with NOMMA's "Voluntary Joint Finish Standards" for Finish #3 - Partially dressed weld with spatter removed as shown in NAAMM AMP 521.
- C. Form changes in direction of railings and guards as follows:
1. As detailed.
- D. For changes in direction made by bending, use jigs to produce uniform curvature for each repetitive configuration required.
1. Maintain cross section of member throughout entire bend without buckling, twisting, cracking, or otherwise deforming exposed surfaces of components.
- E. Close exposed ends of railing and guard members with prefabricated end fittings.
- F. Provide wall returns at ends of wall-mounted handrails unless otherwise indicated.
1. Close ends of returns unless clearance between end of rail and wall is 1/4 inch or less.
- G. Connect posts to stair framing by direct welding unless otherwise indicated.
- H. Brackets, Flanges, Fittings, and Anchors: Provide wall brackets, end closures, flanges, miscellaneous fittings, and anchors for interconnecting components and for attaching to other work.
1. Furnish inserts and other anchorage devices for connecting to concrete or masonry work.
  2. For galvanized railings and guards, provide galvanized fittings, brackets, fasteners, sleeves, and other ferrous-metal components.
- 2.8 FINISHES
- A. Finish metal stairs after assembly.
- B. Galvanizing: Hot-dip galvanize items as indicated to comply with ASTM A153/A153M for steel and iron hardware and with ASTM A123/A123M for other steel and iron products.
1. Do not quench or apply post-galvanizing treatments that might interfere with paint adhesion.

2. Fill vent and drain holes that are exposed in the finished Work, unless indicated to remain as weep holes, by plugging with zinc solder and filing off smooth.
- C. Preparation for Shop Priming: Prepare uncoated ferrous-metal surfaces to comply with minimum requirements indicated below for SSPC surface preparation specifications and environmental exposure conditions of installed products:
1. Interior Stairs: SSPC-SP 6/NACE No. 3, "Commercial Blast Cleaning."
  2. Interior Stairs: SSPC-SP 3, "Power Tool Cleaning."
- D. Apply shop primer to uncoated surfaces of metal stair components, except those with galvanized finishes and those to be embedded in concrete or masonry unless otherwise indicated. Comply with SSPC-PA 1, "Paint Application Specification No. 1: Shop, Field, and Maintenance Painting of Steel," for shop painting.

### PART 3 - EXECUTION

#### 3.1 INSTALLATION OF METAL STAIRS

- A. Fastening to In-Place Construction: Provide anchorage devices and fasteners where necessary for securing metal stairs to in-place construction.
1. Include threaded fasteners for concrete and masonry inserts, through-bolts, lag bolts, and other connectors.
- B. Cutting, Fitting, and Placement: Perform cutting, drilling, and fitting required for installing metal stairs. Set units accurately in location, alignment, and elevation, measured from established lines and levels and free of rack.
- C. Install metal stairs by welding stair framing to steel structure or to weld plates cast into concrete unless otherwise indicated.
1. Grouted Baseplates: Clean concrete and masonry bearing surfaces of bond-reducing materials and roughen to improve bond to surfaces.
    - a. Clean bottom surface of baseplates.
    - b. Set steel-stair baseplates on wedges, shims, or leveling nuts.
    - c. After stairs have been positioned and aligned, tighten anchor bolts.
    - d. Do not remove wedges or shims, but if protruding, cut off flush with edge of bearing plate before packing with grout.
    - e. Promptly pack grout solidly between bearing surfaces and plates to ensure that no voids remain.
      - 1) Neatly finish exposed surfaces; protect grout and allow to cure.
      - 2) Comply with manufacturer's written installation instructions for shrinkage-resistant grouts.
- D. Provide temporary bracing or anchors in formwork for items that are to be built into concrete, masonry, or similar construction.

- E. Fit exposed connections accurately together to form hairline joints.
  - 1. Weld connections that are not to be left as exposed joints but cannot be shop welded because of shipping size limitations.
  - 2. Do not weld, cut, or abrade surfaces of exterior units that have been hot-dip galvanized after fabrication and are for bolted or screwed field connections.
  - 3. Comply with requirements for welding in "Fabrication, General" Article.

### 3.2 INSTALLATION OF RAILINGS AND GUARDS

- A. Adjust railing and guard systems before anchoring to ensure matching alignment at abutting joints with tight, hairline joints.
  - 1. Space posts at spacing indicated or, if not indicated, as required by design loads.
  - 2. Plumb posts in each direction, within a tolerance of 1/16 inch in 3 feet.
  - 3. Align rails and guards so variations from level for horizontal members and variations from parallel with rake of stairs for sloping members do not exceed 1/4 inch in 12 feet.
  - 4. Secure posts, rail ends, and guard ends to building construction as follows:
    - a. Anchor posts to steel by welding or bolting to steel supporting members.
    - b. Anchor handrail and guard ends to concrete and masonry with steel round flanges welded to rail and guard ends and anchored with post-installed anchors and bolts.
- B. Attach handrails to wall with wall brackets.
  - 1. Locate brackets as indicated or, if not indicated, at spacing required to support structural loads.
  - 2. Secure wall brackets to building construction as required to comply with performance requirements.

### 3.3 REPAIR

- A. Touchup Painting: Immediately after erection, clean field welds, bolted connections, and abraded areas of shop paint, and paint exposed areas with same material as used for shop painting to comply with SSPC-PA 1 for touching up shop-painted surfaces.
  - 1. Apply by brush or spray to provide a minimum 2.0-mil dry film thickness.
- B. Galvanized Surfaces: Clean field welds, bolted connections, and abraded areas and repair galvanizing to comply with ASTM A780/A780M.

END OF SECTION 05 51 19

## SECTION 05 53 16 - PLANK GRATINGS

### PART 1 - GENERAL

#### 1.1 SUMMARY

- A. Section Includes:
  - 1. Formed-metal plank gratings.
  - 2. Grating frames and supports.

#### 1.2 ACTION SUBMITTALS

- A. Product Data: For each type of product.
- B. Shop Drawings: Include plans, sections, and attachment details.
- C. Delegated Design Submittals: For gratings.

#### 1.3 INFORMATIONAL SUBMITTALS

- A. Certificates:
  - 1. Paint Compatibility Certificates: From manufacturers of topcoats applied over shop primers certifying that shop primers are compatible with topcoats.
  - 2. Welding certificates.
- B. Delegated design engineer qualifications.

#### 1.4 QUALITY ASSURANCE

- A. Qualifications:
  - 1. Delegated Design Engineer: A professional engineer who is legally qualified to practice in state where Project is located and who is experienced in providing engineering services of the type indicated.
  - 2. Welding Qualifications: Qualify procedures and personnel in accordance with the following welding codes:
    - a. AWS D1.1/D1.1M.
    - b. AWS D1.3/D1.3M.

## PART 2 - PRODUCTS

### 2.1 PERFORMANCE REQUIREMENTS

- A. Structural Performance: Gratings to withstand the effects of gravity loads and the following loads and stresses within limits and under conditions indicated:
1. Floors for Light Manufacturing: Uniform load of 125 lbf/sq. ft. or concentrated load of 2000 lbf, whichever produces the greater stress.
  2. Floors for Heavy Manufacturing: Uniform load of 250 lbf/sq. ft. or concentrated load of 3000 lbf, whichever produces the greater stress.
  3. Walkways and Elevated Platforms Other Than Exits: Uniform load of 60 lbf/sq. ft..
  4. Walkways and Elevated Platforms Used as Exits: Uniform load of 100 lbf/sq. ft..
  5. Limit deflection to L/360 or 1/4 inch, whichever is less.

### 2.2 FORMED-METAL PLANK GRATINGS

- A. C-Shaped Channels: Rolled from heavy sheet metal of thickness indicated, and punched in serrated diamond shape to produce raised slip-resistant surface and drainage holes.

### 2.3 GRATING FRAMES AND SUPPORTS

- A. Frames and Supports: Fabricate from metal shapes, plates, and bars of welded construction to sizes, shapes, and profiles indicated and as necessary to receive gratings. Miter and weld connections for perimeter angle frames. Cut, drill, and tap units to receive hardware and similar items.
1. Unless otherwise indicated, fabricate from same basic metal as gratings.
  2. Equip units indicated to be cast into concrete or built into masonry with integrally welded anchors. Unless otherwise indicated, space anchors 24 inches o.c. and provide minimum anchor units in the form of steel straps 1-1/4 inches wide by 1/4 inch thick by 8 inches long.
- B. Galvanize steel frames and supports in the following locations:
1. Interior where indicated.

### 2.4 FASTENERS

- A. General: Unless otherwise indicated, provide Type 316 stainless steel fasteners for exterior use and zinc-plated fasteners with coating complying with ASTM B633 or ASTM F1941/F1941M, Class Fe/Zn 5, at exterior walls. Select fasteners for type, grade, and class required.

## 2.5 MISCELLANEOUS MATERIALS

- A. Universal Shop Primer: Fast-curing, lead- and chromate-free, universal modified-alkyd primer and compatible with topcoat.
- B. Galvanizing Repair Paint: High-zinc-dust-content paint complying with SSPC-Paint 20 and compatible with paints specified to be used over it.

## 2.6 FERROUS METALS

- A. Steel Plates, Shapes, and Bars: ASTM A36/A36M.
- B. Uncoated Steel Sheet: ASTM A1011/A1011M, structural steel, Grade 30.
- C. Galvanized-Steel Sheet: ASTM A653/A653M, structural quality, Grade 33, with G90 coating.

## 2.7 FABRICATION

- A. Cut, drill, and punch material cleanly and accurately. Remove burrs and ease edges to a radius of approximately 1/32 inch unless otherwise indicated. Remove sharp or rough areas on exposed surfaces.
- B. Fit exposed connections accurately together to form hairline joints.

## 2.8 STEEL FINISHES

- A. Finish gratings, frames, and supports after assembly.
- B. Galvanizing: Hot-dip galvanize items as indicated to comply with ASTM A153/A153M for steel and iron hardware and with ASTM A123/A123M for other steel and iron products.
- C. Shop prime gratings, frames and supports not indicated to be galvanized unless otherwise indicated.
- D. Preparation for Shop Priming: Prepare surfaces to comply with [SSPC-SP 6/NACE No. 3, "Commercial Blast Cleaning."] [SSPC-SP 7/NACE No. 4, "Brush-off Blast Cleaning."]
- E. Shop Priming: Apply shop primer to comply with SSPC-PA 1, "Shop, Field, and Maintenance Painting of Steel," for shop painting.



## PART 3 - EXECUTION

### 3.1 INSTALLATION, GENERAL

- A. Cutting, Fitting, and Placement: Perform cutting, drilling, and fitting required for installing gratings. Set units accurately in location, alignment, and elevation; measured from established lines and levels and free of rack.
- B. Fit exposed connections accurately together to form hairline joints.
  - 1. Weld connections that are not to be left as exposed joints but cannot be shop welded because of shipping size limitations. Do not weld, cut, or abrade the surfaces of exterior units that have been hot-dip galvanized after fabrication and are for bolted or screwed field connections.

### 3.2 INSTALLATION OF METAL PLANK GRATINGS

- A. Comply with manufacturer's written instructions for installing gratings. Use manufacturer's standard anchor clips and hold-down devices for bolted connections.
- B. Attach removable units to supporting members by bolting at every point of contact.
- C. Attach nonremovable units to supporting members by welding unless otherwise indicated. Comply with manufacturer's written instructions for size and spacing of welds.

### 3.3 REPAIR

- A. Repair Painting:
  - 1. Wire brush and clean rust spots, welds, and abraded areas on prime-painted gratings immediately after installation and apply repair paint with same material as used for shop painting to comply with SSPC-PA 1 requirements for touching up shop-painted surfaces.
    - a. Apply by brush or spray to provide a minimum 2.0-mil dry film thickness.
- B. Repair of Galvanized Surfaces: Clean field welds, bolted connections, and abraded areas and repair galvanizing to comply with ASTM A780/A780M.

END OF SECTION 05 53 16

## SECTION 06 10 00 - ROUGH CARPENTRY

### PART 1 - GENERAL

#### 1.1 SUMMARY

##### A. Section Includes:

1. Framing with dimension lumber.
2. Wood blocking and nailers.
3. Wood furring.
4. Wood sleepers.
5. Plywood backing panels.

#### 1.2 ACTION SUBMITTALS

##### A. Product Data:

1. For each type of process and factory-fabricated product.
2. For preservative-treated wood products.

#### 1.3 INFORMATIONAL SUBMITTALS

##### A. Material Certificates:

1. For dimension lumber specified to comply with minimum allowable unit stresses. Indicate species and grade selected for each use and design values approved by the ALSC Board of Review.
2. For preservative-treated wood products. Indicate type of preservative used and net amount of preservative retained.

##### B. Evaluation Reports: For the following, from ICC-ES:

1. Wood-preservative-treated wood.
2. Fire-retardant-treated wood.
3. Engineered wood products.
4. Power-driven fasteners.
5. Post-installed anchors.
6. Metal framing anchors.

## PART 2 - PRODUCTS

### 2.1 WOOD PRODUCTS, GENERAL

- A. Lumber: Comply with DOC PS 20 and applicable rules of grading agencies indicated. If no grading agency is indicated, comply with the applicable rules of any rules-writing agency certified by the ALSC Board of Review. Grade lumber by an agency certified by the ALSC Board of Review to inspect and grade lumber under the rules indicated.
  - 1. Factory mark each piece of lumber with grade stamp of grading agency.
  - 2. Dress lumber, S4S, unless otherwise indicated.
- B. Maximum Moisture Content:
  - 1. Boards: 19 percent.
  - 2. Dimension Lumber: 15 percent for 2-inch nominal thickness or less; 19 percent for more than 2-inch nominal thickness unless otherwise indicated.

### 2.2 PRESERVATIVE TREATMENT

- A. Preservative Treatment by Pressure Process: AWP A U1; Use Category UC2[ for interior construction not in contact with ground, Use Category UC3b for exterior construction not in contact with ground, and Use Category UC4a for items in contact with ground].
  - 1. Preservative Chemicals: Acceptable to authorities having jurisdiction and containing no arsenic or chromium.
- B. Kiln-dry lumber after treatment to a maximum moisture content of 19 percent. Do not use material that is warped or that does not comply with requirements for untreated material.
- C. Mark lumber with treatment quality mark of an inspection agency approved by the ALSC Board of Review.
- D. Application: Treat items indicated on Drawings, and the following:
  - 1. Wood sills, sleepers, blocking, furring, stripping, and similar concealed members in contact with masonry or concrete.
  - 2. Wood floor plates that are installed over concrete slabs-on-grade.

### 2.3 FIRE-RETARDANT-TREATMENT

- A. General: Where fire-retardant-treated materials are indicated, materials shall comply with requirements in this article, that are acceptable to authorities having jurisdiction, and with fire-test-response characteristics specified as determined by testing identical products per test method indicated by a qualified testing agency.

- B. Fire-Retardant-Treated Lumber and Plywood by Pressure Process: Products with a flame-spread index of 25 or less when tested according to ASTM E84, and with no evidence of significant progressive combustion when the test is extended an additional 20 minutes, and with the flame front not extending more than 10.5 feet beyond the centerline of the burners at any time during the test.
  - 1. Interior Type A: Treated materials shall have a moisture content of 28 percent or less when tested according to ASTM D3201/D3201M at 92 percent relative humidity. Use where exterior type is not indicated.
- C. Kiln-dry lumber after treatment to maximum moisture content of 19 percent.
- D. Identify fire-retardant-treated wood with appropriate classification marking of qualified testing agency.
- E. Application: Treat items indicated on Drawings, and the following:
  - 1. Concealed blocking.
  - 2. Framing for non-load-bearing partitions.
  - 3. Plywood backing panels.

#### 2.4 DIMENSION LUMBER FRAMING

- A. Non-Load-Bearing Interior Partitions by Grade: Stud, or No. 3 grade.
  - 1. Application: All interior partitions.
  - 2. Species:
    - a. Southern pine or mixed southern pine; SPIB.
    - b. Northern species; NLGA.
    - c. Eastern softwoods; NeLMA.
    - d. Western woods; WCLIB or WWPA.

#### 2.5 MISCELLANEOUS LUMBER

- A. Provide miscellaneous lumber indicated and lumber for support or attachment of other construction, including the following:
  - 1. Blocking.
  - 2. Nailers.
  - 3. Furring.
  - 4. Grounds.
- B. Dimension Lumber Items: Standard, Stud, or No. 3 grade lumber of any species.
- C. Concealed Boards: 19 percent maximum moisture content and any of the following species and grades:
  - 1. Mixed southern pine or southern pine; No. 3 grade; SPIB.
  - 2. Eastern softwoods; No. 3 Common grade; NeLMA.

3. Northern species; No. 3 Common grade; NLGA.
4. Western woods; Standard or No. 3 Common grade; WCLIB or WWPA.

## 2.6 PLYWOOD BACKING PANELS

- A. Equipment Backing Panels: Plywood, DOC PS 1, fire-retardant treated, in thickness indicated or, if not indicated, not less than 1/2-inch nominal thickness.

## 2.7 FASTENERS

- A. General: Fasteners shall be of size and type indicated and shall comply with requirements specified in this article for material and manufacture. Provide nails or screws, in sufficient length, to penetrate not less than 1-1/2 inches into wood substrate.
  1. Where rough carpentry is exposed to weather, in ground contact, pressure-preservative treated, or in area of high relative humidity, provide fasteners with hot-dip zinc coating complying with ASTM A153/A153M.
- B. Power-Driven Fasteners: Fastener systems with an evaluation report acceptable to authorities having jurisdiction, based on ICC-ES AC70.
- C. Post-Installed Anchors: Fastener systems with an evaluation report acceptable to authorities having jurisdiction, based on ICC-ES AC193 as appropriate for the substrate.

## 2.8 METAL FRAMING ANCHORS

- A. Allowable design loads, as published by manufacturer, shall meet or exceed those indicated. Manufacturer's published values shall be determined from empirical data or by rational engineering analysis and demonstrated by comprehensive testing performed by a qualified independent testing agency. Framing anchors shall be punched for fasteners adequate to withstand same loads as framing anchors.
- B. Galvanized-Steel Sheet: Hot-dip, zinc-coated steel sheet complying with ASTM A653/A653M, G60 coating designation.
  1. Use for interior locations unless otherwise indicated.
- C. Hot-Dip, Heavy-Galvanized Steel Sheet: ASTM A653/A653M; structural steel (SS), high-strength low-alloy steel Type A (HSLAS Type A), or high-strength low-alloy steel Type B (HSLAS Type B); G185 coating designation; and not less than 0.036 inch thick.
  1. Use for wood-preservative-treated lumber and where indicated.

## 2.9 MISCELLANEOUS MATERIALS

- A. Sill-Sealer Gaskets:

1. Closed-cell neoprene foam, 1/4 inch thick, selected from manufacturer's standard widths to suit width of sill members indicated.
- B. Adhesives for Gluing Furring to Concrete or Masonry: Formulation complying with ASTM D3498 that is approved for use indicated by adhesive manufacturer.

### PART 3 - EXECUTION

#### 3.1 INSTALLATION

- A. Framing Standard: Comply with AF&PA's WCD 1, "Details for Conventional Wood Frame Construction," unless otherwise indicated.
- B. Framing with Engineered Wood Products: Install engineered wood products to comply with manufacturer's written instructions.
- C. Set work to required levels and lines, with members plumb, true to line, cut, and fitted. Fit rough carpentry accurately to other construction. Locate furring, nailers, blocking, and similar supports to comply with requirements for attaching other construction.
- D. Install shear wall panels to comply with manufacturer's written instructions.
- E. Install metal framing anchors to comply with manufacturer's written instructions. Install fasteners through each fastener hole.
- F. Do not splice structural members between supports unless otherwise indicated.
- G. Comply with AWPAC M4 for applying field treatment to cut surfaces of preservative-treated lumber.
- H. Where wood-preservative-treated lumber is installed adjacent to metal decking, install continuous flexible flashing separator between wood and metal decking.
- I. Securely attach rough carpentry work to substrate by anchoring and fastening as indicated, complying with the following:
  1. Table 2304.9.1, "Fastening Schedule," in ICC's International Building Code (IBC).
  2. Table R602.3(1), "Fastener Schedule for Structural Members," and Table R602.3(2), "Alternate Attachments," in ICC's International Residential Code for One- and Two-Family Dwellings.
  3. ICC-ES evaluation report for fastener.

#### 3.2 PROTECTION

- A. Protect wood that has been treated with inorganic boron (SBX) from weather. If, despite protection, inorganic boron-treated wood becomes wet, apply EPA-registered borate treatment. Apply borate solution by spraying to comply with EPA-registered label.

- B. Protect rough carpentry from weather. If, despite protection, rough carpentry becomes wet enough that moisture content exceeds that specified, apply EPA-registered borate treatment. Apply borate solution by spraying to comply with EPA-registered label.

END OF SECTION 06 10 00

## SECTION 06 64 00 - PLASTIC PANELING

### PART 1 - GENERAL

#### 1.1 SUMMARY

- A. Section includes plastic sheet paneling.

#### 1.2 ACTION SUBMITTALS

- A. Product Data: For each type of product.
- B. Samples: For plastic paneling and trim accessories.

### PART 2 - PRODUCTS

#### 2.1 PLASTIC SHEET PANELING

- A. Glass-Fiber-Reinforced Plastic Paneling: Gelcoat-finished, glass-fiber-reinforced plastic panels complying with ASTM D5319.
  - 1. Surface-Burning Characteristics: As follows when tested by a qualified testing agency according to ASTM E84. Identify products with appropriate markings of applicable testing agency.
    - a. Flame-Spread Index: 25 or less.
    - b. Smoke-Developed Index: 450 or less.
  - 2. Nominal Thickness: Not less than 0.09 inch.
  - 3. Surface Finish: Molded pebble texture.
  - 4. Color: White.

#### 2.2 ACCESSORIES

- A. Trim Accessories: Manufacturer's standard one-piece vinyl extrusions designed to retain and cover edges of panels. Provide division bars, inside corners, outside corners, and caps as needed to conceal edges.
  - 1. Color: Match panels.
- B. Sealant: Mildew-resistant, single-component, neutral-curing silicone sealant recommended by plastic paneling manufacturer.



## PART 3 - EXECUTION

### 3.1 PREPARATION

- A. Clean substrates of substances that could impair adhesive bond, including oil, grease, dirt, and dust.
- B. Condition panels by unpacking and placing in installation space before installation according to manufacturer's written recommendations.
- C. Lay out paneling before installing. Locate panel joints to provide equal panels at ends of walls not less than half the width of full panels.

### 3.2 INSTALLATION

- A. Install plastic paneling according to manufacturer's written instructions.
- B. Install panels in a full spread of adhesive.
- C. Install trim accessories with adhesive and nails or staples.
- D. Fill grooves in trim accessories with sealant before installing panels, and bed inside corner trim in a bead of sealant.
- E. Maintain uniform space between panels and wall fixtures. Fill space with sealant.
- F. Remove excess sealant and smears as paneling is installed. Clean with solvent recommended by sealant manufacturer and then wipe with clean dry cloths until no residue remains.

END OF SECTION 06 64 00

## SECTION 07 21 00 - THERMAL INSULATION

### PART 1 - GENERAL

#### 1.1 SUMMARY

A. Section Includes:

1. Extruded polystyrene foam-plastic board insulation.
2. Glass-fiber blanket insulation.

#### 1.2 ACTION SUBMITTALS

A. Product Data: For the following:

1. Extruded polystyrene foam-plastic board insulation.
2. Glass-fiber blanket insulation.

#### 1.3 INFORMATIONAL SUBMITTALS

A. Installer's Certification: Listing type, manufacturer, and R-value of insulation installed in each element of the building thermal envelope.

1. Sign, date, and post the certification in a conspicuous location on Project site.

B. Product test reports.

C. Research reports.

### PART 2 - PRODUCTS

#### 2.1 EXTRUDED POLYSTYRENE FOAM-PLASTIC BOARD INSULATION

A. Extruded Polystyrene Board Insulation, Type X: ASTM C578, Type X, 15-psi minimum compressive strength; unfaced.

1. Flame-Spread Index: Not more than 25 when tested in accordance with ASTM E84.
2. Smoke-Developed Index: Not more than 450 when tested in accordance with ASTM E84.
3. Labeling: Provide identification of mark indicating R-value of each piece of insulation 12 inches and wider in width.

## 2.2 GLASS-FIBER BLANKET INSULATION

- A. Glass-Fiber Blanket Insulation, Unfaced: ASTM C665, Type I; passing ASTM E136 for combustion characteristics.
  - 1. Flame-Spread Index: Not more than 25 when tested in accordance with ASTM E84.
  - 2. Smoke-Developed Index: Not more than 50 when tested in accordance with ASTM E84.
  - 3. Labeling: Provide identification of mark indicating R-value of each piece of insulation 12 inches and wider in width.

## 2.3 ACCESSORIES

- A. Insulation Anchors, Spindles, and Standoffs: As recommended by manufacturer.
- B. Adhesive for Bonding Insulation: Product compatible with insulation and air and water barrier materials, and with demonstrated capability to bond insulation securely to substrates without damaging insulation and substrates.

## PART 3 - EXECUTION

### 3.1 INSTALLATION, GENERAL

- A. Comply with insulation manufacturer's written instructions applicable to products and applications.
- B. Install insulation that is undamaged, dry, and unsoiled and that has not been left exposed to ice, rain, or snow at any time.
- C. Install insulation with manufacturer's R-value label exposed after insulation is installed.
- D. Extend insulation to envelop entire area to be insulated. Fit tightly around obstructions and fill voids with insulation. Remove projections that interfere with placement.
- E. Provide sizes to fit applications and selected from manufacturer's standard thicknesses, widths, and lengths. Apply single layer of insulation units unless multiple layers are otherwise shown or required to make up total thickness or to achieve R-value.

### 3.2 INSTALLATION OF FOUNDATION WALL INSULATION

- A. Butt panels together for tight fit.
- B. Anchor Installation: Install board insulation on concrete substrates by adhesively attached, spindle-type insulation anchors.

- C. Adhesive Installation: Install with adhesive or press into tacky waterproofing or damp-proofing according to manufacturer's written instructions.

### 3.3 INSTALLATION OF INSULATION IN FRAMED CONSTRUCTION

- A. Blanket Insulation: Install in cavities formed by framing members according to the following requirements:

1. Use insulation widths and lengths that fill the cavities formed by framing members. If more than one length is required to fill the cavities, provide lengths that will produce a snug fit between ends.
2. Place insulation in cavities formed by framing members to produce a friction fit between edges of insulation and adjoining framing members.
3. Maintain 3-inch clearance of insulation around recessed lighting fixtures not rated for or protected from contact with insulation.
4. For metal-framed wall cavities where cavity heights exceed 96 inches, support unfaced blankets mechanically and support faced blankets by taping flanges of insulation to flanges of metal studs.
5. Vapor-Retarder-Faced Blankets: Tape joints and ruptures in vapor-retarder facings and seal each continuous area of insulation to ensure airtight installation.

- a. Interior Walls: Set units with facing placed toward areas of high humidity.

- B. Miscellaneous Voids: Install insulation in miscellaneous voids and cavity spaces where required to prevent gaps in insulation using the following materials:

1. Glass-Fiber Insulation: Compact to approximately 40 percent of normal maximum volume equaling a density of approximately 2.5 lb/cu. ft.
2. Spray Polyurethane Insulation: Apply according to manufacturer's written instructions.

END OF SECTION 07 21 00

## SECTION 08 11 13 - HOLLOW METAL DOORS AND FRAMES

### PART 1 - GENERAL

#### 1.1 RELATED DOCUMENTS

- A. Drawings and general provisions of the Contract, including General and Supplementary Conditions and Division 01 Specification Sections, apply to this Section.

#### 1.2 SUMMARY

- A. Section includes:
  - 1. Interior custom hollow-metal doors and frames.
  - 2. Exterior custom hollow-metal doors and frames.

#### 1.3 ACTION SUBMITTALS

- A. Product Data: For each type of product.
- B. Shop Drawings: Include the following:
  - 1. Elevations of each door type.
  - 2. Details of doors, including vertical- and horizontal-edge details and metal thicknesses.
  - 3. Frame details for each frame type, including dimensioned profiles and metal thicknesses.
- C. Product Schedule: For hollow-metal doors and frames, prepared by or under the supervision of supplier, using same reference numbers for details and openings as those on Drawings. Coordinate with final door hardware schedule.

#### 1.4 INFORMATIONAL SUBMITTALS

- A. Product test reports.
- B. Field quality control reports.

#### 1.5 CLOSEOUT SUBMITTALS

- A. Record Documents: For fire-rated doors, list of door numbers and applicable room name and number to which door accesses.

## 1.6 QUALITY ASSURANCE

- A. Fire-Rated Door Inspector Qualifications: Inspector for field quality control inspections of fire-rated door assemblies shall meet the qualifications set forth in NFPA 80, Section 5.2.3.1 and the following:
  - 1. Door and Hardware Institute Fire and Egress Door Assembly Inspector (FDAI) certification.
- B. Egress Door Inspector Qualifications: Inspector for field quality control inspections of egress door assemblies shall meet the qualifications set forth in NFPA 101, Section 7.2.1.15.4 and the following:
  - 1. Door and Hardware Institute Fire and Egress Door Assembly Inspector (FDAI) certification.

## PART 2 - PRODUCTS

### 2.1 PERFORMANCE REQUIREMENTS

- A. Fire-Rated Door Assemblies: Assemblies complying with NFPA 80 that are listed and labeled by a qualified testing agency acceptable to authorities having jurisdiction for fire-protection ratings indicated on Drawings, based on testing at positive pressure according to NFPA 252 or UL 10C.
  - 1. Smoke- and Draft-Control Door Assemblies: Listed and labeled for smoke and draft control by a qualified testing agency acceptable to authorities having jurisdiction, based on testing according to UL 1784 and installed in compliance with NFPA 105.
  - 2. Temperature-Rise Limit: At vertical exit enclosures and exit passageways provide doors that have a maximum transmitted temperature end point of not more than 450 deg F above ambient after 30 minutes of standard fire-test exposure.

### 2.2 INTERIOR CUSTOM HOLLOW-METAL DOORS AND FRAMES

- A. Hollow-Metal Doors and Frames: NAAMM-HMMA 860; ANSI/SDI A250.4, Physical Performance Level A.
  - 1. Doors:
    - a. Type: As indicated in the Door and Frame Schedule.
    - b. Thickness: 1-3/4 inches.
    - c. Face: Steel sheet, minimum thickness of 0.032 inch.
    - d. Core: Steel stiffened.
    - e. Fire-Rated Core: Manufacturer's standard vertical steel stiffener core for fire-rated and temperature-rise-rated doors.
  - 2. Frames:

- a. Materials: Steel sheet, minimum thickness of 0.053 inch.
  - b. Construction: Face welded.
- B. Commercial Doors and Frames: NAAMM-HMMA 861; ANSI/SDI A250.4, Physical Performance Level A.
- 1. Doors:
    - a. Type: As indicated in the Door and Frame Schedule.
    - b. Thickness: 1-3/4 inches.
    - c. Face: Steel sheet, minimum thickness of 0.042 inch.
    - d. Edge Construction: Continuously welded with no visible seam.
    - e. Core: Steel stiffened.
    - f. Fire-Rated Core: Manufacturer's standard vertical steel stiffener core for fire-rated and temperature-rise-rated doors.
  - 2. Frames:
    - a. Materials: Steel sheet, minimum thickness of 0.053 inch, except 0.067 inch for openings exceeding 4 feet wide.
    - b. Construction: Face welded.

## 2.3 EXTERIOR CUSTOM HOLLOW-METAL DOORS AND FRAMES

- A. Commercial Doors and Frames: NAAMM-HMMA 861; ANSI/SDI A250.4, Physical Performance Level A.
- 1. Doors:
    - a. Type: As indicated in the Door and Frame Schedule.
    - b. Thickness: 1-3/4 inches.
    - c. Face: Metallic-coated steel sheet, minimum thickness of 0.053 inch, with minimum G60 or A60 coating.
    - d. Edge Construction: Continuously welded with no visible seam.
    - e. Top Edge Closures: Close top edges of doors with flush closures of same material as face sheets. Seal joints against water penetration.
    - f. Bottom Edges: Close bottom edges of doors where required for attachment of weather stripping with end closures or channels of same material as face sheets. Provide weep-hole openings in bottoms of exterior doors to permit moisture to escape.
  - 2. Frames:
    - a. Materials: Metallic-coated steel sheet, minimum thickness of 0.053 inch, except 0.067 inch for openings exceeding 4 feet wide; with minimum G60 or A60 coating.
    - b. Construction: Face welded.

## 2.4 MATERIALS

- A. Cold-Rolled Steel Sheet: ASTM A1008/A1008M, Commercial Steel (CS), Type B; suitable for exposed applications.
- B. Hot-Rolled Steel Sheet: ASTM A1011/A1011M, Commercial Steel (CS), Type B; free of scale, pitting, or surface defects; pickled and oiled.
- C. Metallic-Coated Steel Sheet: ASTM A653/A653M, Commercial Steel (CS), Type B.
- D. Inserts, Bolts, and Fasteners: Hot-dip galvanized according to ASTM A153/A153M.
- E. Power-Actuated Fasteners in Concrete: Fastener system of type suitable for application indicated, fabricated from corrosion-resistant materials, with clips or other accessory devices for attaching hollow-metal frames of type indicated.
- F. Mineral-Fiber Insulation: ASTM C665, Type I (blankets without membrane facing); consisting of fibers manufactured from slag or rock wool; with maximum flame-spread and smoke-developed indexes of 25 and 50, respectively; passing ASTM E136 for combustion characteristics.
- G. Glazing: Comply with requirements in Section 08 80 00 "Glazing."

## 2.5 FABRICATION

- A. Door Astragals: Provide overlapping astragal on one leaf of pairs of doors where required by NFPA 80 for fire-performance rating or where indicated. Extend minimum 3/4 inch beyond edge of door on which astragal is mounted or as required to comply with published listing of qualified testing agency.
- B. Hollow-Metal Frames: Fabricate in one piece except where handling and shipping limitations require multiple sections. Where frames are fabricated in sections, provide alignment plates or angles at each joint, fabricated of metal of same or greater thickness as frames.
  - 1. Provide countersunk, flat- or oval-head exposed screws and bolts for exposed fasteners unless otherwise indicated.
  - 2. Door Silencers: Except on weather-stripped frames, drill stops to receive door silencers as follows. Keep holes clear during construction.
    - a. Single-Door Frames: Drill stop in strike jamb to receive three door silencers.
    - b. Double-Door Frames: Drill stop in head jamb to receive two door silencers.
- C. Hardware Preparation: Factory prepare hollow-metal doors and frames to receive templated mortised hardware, and electrical wiring; include cutouts, reinforcement, mortising, drilling, and tapping according to ANSI/SDI A250.6, the Door Hardware Schedule, and templates.



1. Reinforce doors and frames to receive non-templated, mortised, and surface-mounted door hardware.
2. Comply with BHMA A156.115 for preparing hollow-metal doors and frames for hardware.

### PART 3 - EXECUTION

#### 3.1 PREPARATION

- A. Remove welded-in shipping spreaders installed at factory. Restore exposed finish by grinding, filling, and dressing, as required to make repaired area smooth, flush, and invisible on exposed faces. Touch up factory-applied finishes where spreaders are removed.
- B. Drill and tap doors and frames to receive non-templated, mortised, and surface-mounted door hardware.

#### 3.2 INSTALLATION

- A. Hollow-Metal Frames: Comply with NAAMM-HMMA 840.
  1. Set frames accurately in position; plumbed, aligned, and braced securely until permanent anchors are set. After wall construction is complete, remove temporary braces without damage to completed Work.
    - a. Where frames are fabricated in sections, field splice at approved locations by welding face joint continuously; grind, fill, dress, and make splice smooth, flush, and invisible on exposed faces. Touch-up finishes.
    - b. Install frames with removable stops located on secure side of opening.
  2. Fire-Rated Openings: Install frames according to NFPA 80.
  3. Floor Anchors: Secure with post-installed expansion anchors.
    - a. Floor anchors may be set with power-actuated fasteners instead of post-installed expansion anchors if so indicated and approved on Shop Drawings.
  4. Solidly pack mineral-fiber insulation inside frames.
  5. Masonry Walls: Coordinate installation of frames to allow for solidly filling space between frames and masonry with grout or mortar.
  6. In-Place Concrete or Masonry Construction: Secure frames in place with post-installed expansion anchors. Countersink anchors, and fill and make smooth, flush, and invisible on exposed faces.
  7. Installation Tolerances: Adjust hollow-metal frames to the following tolerances:
    - a. Squareness: Plus or minus 1/16 inch, measured at door rabbet on a line 90 degrees from jamb perpendicular to frame head.

- b. Alignment: Plus or minus 1/16 inch, measured at jambs on a horizontal line parallel to plane of wall.
  - c. Twist: Plus or minus 1/16 inch, measured at opposite face corners of jambs on parallel lines, and perpendicular to plane of wall.
  - d. Plumbness: Plus or minus 1/16 inch, measured at jambs at floor.
- B. Hollow-Metal Doors: Fit and adjust hollow-metal doors accurately in frames, within clearances specified below.
- 1. Non-Fire-Rated Steel Doors: Comply with NAAMM-HMMA 841 and NAAMM-HMMA guide specification indicated.
  - 2. Fire-Rated Doors: Install doors with clearances according to NFPA 80.
  - 3. Smoke-Control Doors: Install doors according to NFPA 105.

### 3.3 FIELD QUALITY CONTROL

- A. Inspection Agency: Engage a qualified inspector to perform inspections and to furnish reports to Architect.
- B. Inspections:
- 1. Fire-Rated Door Inspections: Inspect each fire-rated door according to NFPA 80, Section 5.2.
- C. Repair or remove and replace installations where inspections indicate that they do not comply with specified requirements.
- D. Reinspect repaired or replaced installations to determine if replaced or repaired door assembly installations comply with specified requirements.
- E. Prepare and submit separate inspection report for each fire-rated door assembly indicating compliance with each item listed in NFPA 80 and NFPA 101.

### 3.4 REPAIR

- A. Prime-Coat Touchup: Immediately after erection, sand smooth rusted or damaged areas of prime coat and apply touchup of compatible air-drying, rust-inhibitive primer.
- B. Metallic-Coated Surface Touchup: Clean abraded areas and repair with galvanizing repair paint according to manufacturer's written instructions.
- C. Touchup Painting: Cleaning and touchup painting of abraded areas of paint are specified in painting Sections.

END OF SECTION 08 11 13

## SECTION 08 36 13 - SECTIONAL DOORS

### PART 1 - GENERAL

#### 1.1 SUMMARY

- A. Section Includes:
  - 1. Sectional-door assemblies.

#### 1.2 ACTION SUBMITTALS

- A. Product Data: For each type and size of sectional door and accessory.
- B. Shop Drawings: For each installation and for components not dimensioned or detailed in manufacturer's product data.
- C. Samples: For each exposed product and for each color and texture specified.

#### 1.3 INFORMATIONAL SUBMITTALS

- A. Sample warranties.

#### 1.4 CLOSEOUT SUBMITTALS

- A. Maintenance data.

#### 1.5 QUALITY ASSURANCE

- A. Installer Qualifications: An entity that employs installers and supervisors who are trained and approved by manufacturer for both installation and maintenance of units required for this Project.

#### 1.6 WARRANTY

- A. Manufacturer's Warranty: Manufacturer agrees to repair or replace components of sectional doors that fail in materials or workmanship within specified warranty period.
- B. Finish Warranty: Manufacturer agrees to repair or replace components that show evidence of deterioration of factory-applied finishes within specified warranty period.

## PART 2 - PRODUCTS

### 2.1 PERFORMANCE REQUIREMENTS

- A. General Performance: Provide sectional doors that comply with performance requirements specified without failure from defective manufacture, fabrication, installation, or other defects in construction.
- B. Structural Performance, Exterior Doors: Capable of withstanding the design wind loads.
  - 1. Garage-Door Glazed Openings: Pass DASMA 115.

### 2.2 SECTIONAL-DOOR ASSEMBLY

- A. Steel Sectional Door: Provide sectional door formed with hinged sections and fabricated so that finished door assembly is rigid and aligned with tight hairline joints; free of warp, twist, and deformation; and complies with requirements in DASMA 102.
  - 1. Overhead Door "Thermacore" Sectional Steel Door 591
- B. Operation Cycles: Door components and operators capable of operating for not less than 10,000 operation cycles. One operation cycle is complete when door is opened from closed position to the open position and returned to closed position.
- C. Air Infiltration: Maximum rate of 0.8 cfm/sq. ft. when tested in accordance with ASTM E283 or DASMA 105.
- D. U-Value: 0.7 (.38m<sup>2</sup>/W).
- E. Steel Door Sections: ASTM A653/A653M, zinc-coated (galvanized), cold-rolled, commercial steel sheet with zinc coating.
  - 1. Door-Section Thickness: 1-5/8 inches.
  - 2. Section Faces:
    - a. Thermal-Break Construction: Provide sections with continuous thermal-break construction separating the exterior and interior faces of door.
    - b. Exterior Face: Fabricated from single sheets with horizontal meeting edges rolled to continuous, interlocking, keyed, rabbeted, shiplap, or tongue-in-groove, weather- and pinch-resistant seals and reinforcing flange return.
      - 1) Surface: Manufacturer's standard, ribbed.
    - c. Interior Face: Enclose insulation completely within steel exterior facing and interior facing material, with no exposed insulation.
  - 3. End Stiles: Enclose open ends of sections with channel end stiles formed from galvanized-steel sheet per manufacturer.

4. Thermal Insulation: Insulate interior of steel sections with door manufacturer's standard insulation.
- F. Track: Manufacturer's standard, galvanized-steel track system. Provide complete system including brackets, bracing, and reinforcement to ensure rigid support of ball-bearing roller guides.
1. Material: Galvanized steel, ASTM A653/A653M, minimum G60 zinc coating.
  2. Size: 2-inch standard radius track.
  3. Track Reinforcement and Supports: Provide galvanized-steel members to support track without sag, sway, and vibration during opening and closing of doors. Slot vertical sections of track spaced 2 inches apart for door-drop safety device.
- G. Weather seals: Replaceable, adjustable, continuous, compressible weather-stripping gaskets of flexible vinyl, rubber, or neoprene fitted to bottom of door.
- H. Windows: Manufacturer's standard window units of shape and size and in locations indicated on Drawings. Set glazing in vinyl, rubber, or neoprene glazing channel. Provide removable stops of same material as door-section frames. Provide the following glazing:
1. Insulating Glass Units: Insulated DSB, 24" wide by 7" high per manufacturer.
- I. Exhaust Port: Manufacturer's standard, installed in bottom section.
- J. Hardware: Heavy-duty, corrosion-resistant hardware, with hot-dip galvanized, stainless steel, or other corrosion-resistant fasteners, to suit door type.
1. Hinges: Heavy-duty, galvanized-steel hinges of not less than 0.079-inch nominal coated thickness at each end stile and at each intermediate stile, in accordance with manufacturer's written recommendations for door size.
    - a. Attach hinges to door sections through stiles and rails with bolts and lock nuts or lock washers and nuts. Use rivets or self-tapping fasteners where access to nuts is impossible.
  2. Rollers: Heavy-duty rollers with steel ball bearings in case-hardened steel races, mounted to suit slope of track. Extend roller shaft through both hinges where double hinges are required. Match roller-tire diameter to track width.
- K. Locking Device:
1. Safety Interlock Switch: Equip power-operated doors with safety interlock switch to disengage power supply when door is locked.
- L. Counterbalance Mechanism:
1. Torsion Spring: Adjustable-tension torsion springs complying with requirements of DASMA 102 for number of operation cycles indicated, mounted on torsion shaft.

2. Cable Drums and Shaft for Doors: Cast-aluminum cable drums mounted on torsion shaft and grooved to receive door-lifting cables as door is raised.
    - a. Mount counterbalance mechanism with manufacturer's standard ball-bearing brackets at each end of torsion shaft.
  3. Cables: Galvanized-steel, multistrand, lifting cables.
  4. Cable Safety Device: Include a spring-loaded steel or bronze cam mounted to bottom door roller assembly on each side and designed to automatically stop door if lifting cable breaks.
  5. Bracket: Provide anchor support bracket as required to connect stationary end of spring to the wall and to level the shaft and prevent sag.
  6. Bumper: Provide spring bumper at each horizontal track to cushion door at end of opening operation.
- M. Electric Door Operator: Electric door operator assembly of size and capacity recommended by door manufacturer for door and operation cycles specified, with electric motor and factory-prewired motor controls, starter, gear-reduction unit, solenoid-operated brake, clutch, control stations, control devices, integral gearing for locking door, and accessories required for proper operation.
1. Comply with NFPA 70.
  2. Control equipment complying with NEMA ICS 1, NEMA ICS 2, and NEMA ICS 6; with NFPA 70, Class 2 control circuit, maximum 24 V ac or dc.
  3. Operator Type:  $\frac{3}{4}$  HP 115 volt single phase side mount type operator with 3-button controls.
- N. Metal Finish:
1. Factory Prime Steel Finish: Compatible with factory applied finish and in manufacturer's standard color.
  2. Factory Finish: Standard White

## PART 3 - EXECUTION

### 3.1 INSTALLATION

- A. Install sectional doors and operating equipment complete with necessary hardware, anchors, inserts, hangers, and equipment supports, in accordance with manufacturer's written instructions.
- B. Tracks:
1. Fasten vertical track assembly to opening jambs and framing with fasteners spaced not more than 24 inches apart.
  2. Hang horizontal track assembly from structural overhead framing with angles or channel hangers attached to framing by welding or bolting, or both. Provide sway bracing, diagonal bracing, and reinforcement as required for rigid installation of track and door-operating equipment.

- C. Accessibility: Install sectional doors, switches, and controls along accessible routes in compliance with regulatory requirements for accessibility.
- D. Power-Operated Doors: Install in accordance with UL 325.

3.2 DEMONSTRATION

- A. Engage a factory-authorized service representative to train Owner's maintenance personnel to adjust, operate, and maintain sectional doors.

END OF SECTION 08 36 13

## SECTION 08 51 13 - ALUMINUM WINDOWS

### PART 1 - GENERAL

#### 1.1 SUMMARY

- A. Section includes aluminum windows for exterior locations.

#### 1.2 PREINSTALLATION MEETINGS

- A. Preinstallation Conference: Conduct conference at Project site.

#### 1.3 ACTION SUBMITTALS

- A. Product Data: For each type of product.
- B. Shop Drawings: Include plans, elevations, sections, hardware, accessories, insect screens, operational clearances, and details of installation, including anchor, flashing, and sealant installation.
- C. Samples: For each exposed product and for each color specified.

#### 1.4 INFORMATIONAL SUBMITTALS

- A. Product test reports.
- B. Sample warranties.

#### 1.5 WARRANTY

- A. Manufacturer's Warranty: Manufacturer agrees to repair or replace aluminum windows that fail in materials or workmanship within specified warranty period.

### PART 2 - PRODUCTS

#### 2.1 WINDOW PERFORMANCE REQUIREMENTS

- A. Product Standard: Comply with AAMA/WDMA/CSA 101/I.S.2/A440 for definitions and minimum standards of performance, materials, components, accessories, and fabrication unless more stringent requirements are indicated.
  - 1. Window Certification: AAMA certified with label attached to each window.



- B. Performance Class and Grade: AAMA/WDMA/CSA 101/I.S.2/A440 as follows:
  - 1. Minimum Performance Class: LC
  - 2. Minimum Performance Grade: 25
- C. Condensation-Resistance Factor (CRF): Provide aluminum windows tested for thermal performance according to AAMA 1503.
- D. Thermal Movements: Provide aluminum windows, including anchorage, that allow for thermal movements resulting from the following maximum change (range) in ambient and surface temperatures by preventing buckling, opening of joints, overstressing of components, failure of joint sealants, failure of connections, and other detrimental effects. Base engineering calculation on surface temperatures of materials due to both solar heat gain and nighttime-sky heat loss.

## 2.2 ALUMINUM WINDOWS

- A. Manufacturer: Wojan Window and Door Corporation
- B. Types: M-85 Horizontal Slider
- C. Frames and Sashes: Aluminum extrusions complying with AAMA/WDMA/CSA 101/I.S.2/A440.
  - 1. Polyurethane thermal break.
- D. Glass: Clear annealed glass, ASTM C1036, Type 1, Class 1, q3.
- E. Insulating-Glass Units: ASTM E2190.
  - 1. Glass: ASTM C1036, Type 1, Class 1, q3.
    - a. Tint: Clear
  - 2. Filling: Fill space between glass lites with air.
  - 3. Low-E Coating
- F. Glazing System: Manufacturer's standard factory-glazing system that produces weathertight seal.
- G. Hardware, General: Provide manufacturer's standard corrosion-resistant hardware sized to accommodate sash weight and dimensions.
  - 1. Exposed Hardware Color and Finish: As indicated by manufacturer's designations.
- H. Horizontal-Sliding Window Hardware:
  - 1. Sill Cap/Track: Designed to comply with performance requirements indicated and to drain to the exterior.
  - 2. Locks and Latches: Operated from the inside only.

3. Roller Assemblies: Low-friction design.

- I. Weather Stripping: Provide full-perimeter weather stripping for each operable sash unless otherwise indicated.
- J. Fasteners: Noncorrosive and compatible with window members, trim, hardware, anchors, and other components.
  - 1. Exposed Fasteners: Do not use exposed fasteners to greatest extent possible. For application of hardware, use fasteners that match finish hardware being fastened.

2.3 ACCESSORIES

- A. Interior Trim: Extruded-aluminum profiles in sizes and configurations indicated on Drawings.
- B. Panning Trim: Extruded-aluminum profiles in sizes and configurations indicated on Drawings.
- C. Receptor System: Two-piece, snap-together, thermally broken, extruded-aluminum receptor system that anchors windows in place.

2.4 INSECT SCREENS

- A. General: Fabricate insect screens to integrate with window frame. Provide screen for each operable exterior sash. Screen wickets are not permitted.
- B. Aluminum Frames: Complying with SMA 1004 or SMA 1201.
- C. Glass-Fiber Mesh Fabric: Mesh of PVC-coated, glass-fiber threads; woven and fused to form a fabric mesh resistant to corrosion, shrinkage, stretch, impact damage, and weather deterioration. Comply with ASTM D3656/D3656M.
  - 1. Mesh Color: Manufacturer's standard.

2.5 FABRICATION

- A. Fabricate aluminum windows in sizes indicated. Include a complete system for assembling components and anchoring windows.
- B. Glaze aluminum windows in the factory.
- C. Weather strip each operable sash to provide weathertight installation.
- D. Weep Holes: Provide weep holes and internal passages to conduct infiltrating water to exterior.

- E. Complete fabrication, assembly, finishing, hardware application, and other work in the factory to greatest extent possible. Disassemble components only as necessary for shipment and installation.

## 2.6 ALUMINUM FINISHES

- A. Baked-Enamel Finish: AA-C12C42R1x (Chemical Finish: cleaned with inhibited chemicals; Chemical Finish: acid-chromate-fluoride-phosphate conversion coating; Organic Coating: as specified below). Apply baked enamel complying with paint manufacturer's written instructions for cleaning, conversion coating, and painting.
  - 1. Color: As indicated by manufacturer's designations.

## PART 3 - EXECUTION

### 3.1 INSTALLATION

- A. Comply with manufacturer's written instructions for installing windows, hardware, accessories, and other components. For installation procedures and requirements not addressed in manufacturer's written instructions, comply with installation requirements in ASTM E2112.
- B. Install windows level, plumb, square, true to line, without distortion or impeding thermal movement, anchored securely in place to structural support, and in proper relation to wall flashing and other adjacent construction to produce weathertight construction.
- C. Install windows and components to drain condensation, water penetrating joints, and moisture migrating within windows to the exterior.
- D. Separate aluminum and other corrodible surfaces from sources of corrosion or electrolytic action at points of contact with other materials.
- E. Adjust operating sashes and hardware for a tight fit at contact points and weather stripping for smooth operation and weathertight closure.
- F. Clean exposed surfaces immediately after installing windows. Avoid damaging protective coatings and finishes. Remove excess sealants, glazing materials, dirt, and other substances.
- G. Remove and replace glass that has been broken, chipped, cracked, abraded, or damaged during construction period.

END OF SECTION 08 51 13

## SECTION 08 71 00 - DOOR HARDWARE

### PART 1 - GENERAL

#### 1.1 SUMMARY

A. Section Includes:

1. Mechanical door hardware for the following:
  - a. Swinging doors.
2. Cylinders for door hardware specified in other Sections.

#### 1.2 PREINSTALLATION MEETINGS

- A. Preinstallation Conference: Conduct conference at Project site.
- B. Keying Conference: Conduct conference at Project site.

#### 1.3 ACTION SUBMITTALS

- A. Product Data: For each type of product.
- B. Samples: For each exposed product in each finish specified.
- C. Door hardware schedule.
- D. Keying schedule.

#### 1.4 INFORMATIONAL SUBMITTALS

- A. Sample warranty.

#### 1.5 CLOSEOUT SUBMITTALS

- A. Maintenance data.

#### 1.6 QUALITY ASSURANCE

- A. Installer Qualifications: Supplier of products and an employer of workers trained and approved by product manufacturers and of an Architectural Hardware Consultant who is available during the course of the Work to consult Contractor, Architect, and Owner about door hardware and keying.

1. Scheduling Responsibility: Preparation of door hardware and keying schedule.
- B. Architectural Hardware Consultant Qualifications: A person who is experienced in providing consulting services for door hardware installations that are comparable in material, design, and extent to that indicated for this Project and who is currently certified by DHI.

## 1.7 WARRANTY

- A. Special Warranty: Manufacturer agrees to repair or replace components of door hardware that fail in materials or workmanship within specified warranty period.

## PART 2 - PRODUCTS

### 2.1 PERFORMANCE REQUIREMENTS

- A. Fire-Rated Door Assemblies: Where fire-rated doors are indicated, provide door hardware complying with NFPA 80 that is listed and labeled by a qualified testing agency, for fire-protection ratings indicated, based on testing at positive pressure according to NFPA 252 or UL 10C.
- B. Means of Egress Doors: Latches do not require more than 15 lbf to release the latch. Locks do not require use of a key, tool, or special knowledge for operation.
- C. Accessibility Requirements: For door hardware on doors in an accessible route, comply with the USDOJ's "2010 ADA Standards for Accessible Design.

### 2.2 HINGES

- A. Hinges: BHMA A156.1. Provide template-produced hinges for hinges installed on hollow-metal doors and hollow-metal frames.
  1. Ball-bearing type hinges – match existing building standard.

### 2.3 MECHANICAL LOCKS AND LATCHES

- A. Lock Functions: As indicated in door hardware schedule.
- B. Lock Throw: Comply with testing requirements for length of bolts required for labeled fire doors, and as follows:
  1. Bored Locks: Minimum 1/2-inch latch bolt throw.
  2. Deadbolts: Minimum 1-inch bolt throw.
- C. Lock Backset: 2-3/4 inches unless otherwise indicated.

- D. Strikes: Provide manufacturer's standard strike for each lock bolt or latch bolt complying with requirements indicated for applicable lock or latch and with strike box and curved lip extended to protect frame; finished to match lock or latch.
  - 1. Flat-Lip Strikes: For locks with three-piece antifriction latch bolts, as recommended by manufacturer.
- E. Bored Locks: BHMA A156.2; Grade 2; Series 4000.

#### 2.4 AUXILIARY LOCKS

- A. Bored Auxiliary Locks: BHMA A156.36: Grade 2; with strike that suits frame.

#### 2.5 LOCK CYLINDERS

- A. Lock Cylinders: Tumbler type, constructed from brass or bronze, stainless steel, or nickel silver. Provide cylinder from same manufacturer of locking devices.
- B. Standard Lock Cylinders: BHMA A156.5; Grade 2 permanent cores; face finished to match lockset.

#### 2.6 KEYING

- A. Keying System: Factory registered, complying with guidelines in BHMA A156.28, appendix. Provide one extra key blank for each lock. Owner to coordinate keying with existing system master key system.
- B. Keys: Nickel Silver or Brass.
  - 1. Stamping: Permanently inscribe each key with a visual key control number and include information to be furnished by owner.

#### 2.7 SURFACE CLOSERS

- A. Surface Closers: BHMA A156.4; rack-and-pinion hydraulic type with adjustable sweep and latch speeds controlled by key-operated valves and forged-steel main arm. Comply with manufacturer's written instructions for size of door closers depending on size of door, exposure to weather, and anticipated frequency of use. Provide factory-sized closers, adjustable to meet field conditions and requirements for opening force.
  - 1. Heavy-duty door closer – match existing building standard.

#### 2.8 MECHANICAL STOPS AND HOLDERS

- A. Wall- and Floor-Mounted Stops: BHMA A156.16.
  - 1. Wall-mounted stops – match existing building standard.

## 2.9 DOOR GASKETING

- A. Door Gasketing: BHMA A156.22; with resilient or flexible seal strips that are easily replaceable and readily available from stocks maintained by manufacturer.
- B. Maximum Air Leakage: When tested according to ASTM E283 with tested pressure differential of 0.3-inch wg, as follows:
  - 1. Gasketing on Single Doors: 0.3 cfm/sq. ft. of door opening.

## 2.10 THRESHOLDS

- A. Thresholds: BHMA A156.21; fabricated to full width of opening indicated.
  - 1. Aluminum thresholds – match existing building standard.

## 2.11 FINISHES

- A. Provide finishes complying with BHMA A156.18.
  - 1. Schlage brand satin stainless steel – match existing building standard.

## PART 3 - EXECUTION

### 3.1 INSTALLATION

- A. Mounting Heights: Mount door hardware units at heights to comply with the following unless otherwise indicated or required to comply with governing regulations.
  - 1. Standard Steel Doors and Frames: ANSI/SDI A250.8.
  - 2. Custom Steel Doors and Frames: HMMA 831.
- B. Install each door hardware item to comply with manufacturer's written instructions. Where cutting and fitting are required to install door hardware onto or into surfaces that are later to be painted or finished in another way, coordinate removal, storage, and reinstallation of surface protective trim units with finishing work. Do not install surface-mounted items until finishes have been completed on substrates involved.
- C. Hinges: Install types and in quantities indicated in door hardware schedule, but not fewer than the number recommended by manufacturer for application indicated or one hinge for every 30 inches of door height, whichever is more stringent, unless other equivalent means of support for door, such as spring hinges or pivots, are provided.
- D. Lock Cylinders: Install construction cores to secure building and areas during construction period.
  - 1. Replace construction cores with permanent cores as directed by Owner.

- E. Key Control Cabinet: Tag keys and place them on markers and hooks in key control system cabinet, as determined by final keying schedule.
- F. Stops: Provide floor stops for doors unless wall or other type stops are indicated in door hardware schedule. Do not mount floor stops where they will impede traffic.
- G. Perimeter Gasketing: Apply to head and jamb, forming seal between door and frame.
  - 1. Do not notch perimeter gasketing to install other surface-applied hardware.
- H. Door Bottoms: Apply to bottom of door, forming seal with threshold when door is closed.

### 3.2 ADJUSTING

- A. Adjust and check each operating item of door hardware and each door to ensure proper operation or function of every unit. Replace units that cannot be adjusted to operate as intended. Adjust door control devices to compensate for final operation of heating and ventilating equipment and to comply with referenced accessibility requirements.

### 3.3 DOOR HARDWARE SCHEDULE

- A. Hardware Set 1: Each door to have the following:
  - 1. Heavy-duty "Schlage" brand "D" series keyed entrance lever lockset – match existing building standard.
  - 2. Ball-bearing hinges.
  - 3. Heavy-duty surface mounted closer – match existing building standard.
  - 4. Aluminum threshold – match existing building standard.
  - 5. Strip door sweep – match existing building standard.
  - 6. Gasket weatherstripping – match existing building standard.
  - 7. Latch guard – match existing building standard.
- B. Hardware Set 2: Each door to have the following:
  - 1. "Schlage" brand privacy lever lockset with thumb turn.
  - 2. Ball-bearing hinges.
  - 3. Wall-mounted stop.
- C. Hardware Set 3: Each door to have the following:
  - a. "Schlage" brand passage lever, Fire rated.
  - b. Ball-bearing hinges.
  - c. Heavy-duty closer.
- D. Interior Washbay Door (Door 101C per Drawings):
  - a. "Schlage" brand passage lever.
  - b. Ball-bearing hinges.



- c. Heavy-duty surface mounted closer – match existing building standard.
- d. Gasket weatherstripping.

END OF SECTION 08 71 00

## SECTION 09 29 00 - GYPSUM BOARD

### PART 1 - GENERAL

#### 1.1 SUMMARY

A. Section Includes:

1. Interior gypsum board.

#### 1.2 ACTION SUBMITTALS

A. Product Data: For the following:

1. Gypsum wallboard.
2. Gypsum ceiling board.
3. Mold-resistant gypsum board.
4. Interior trim.
5. Joint treatment materials.
6. Textured finishes.

B. Samples: For each texture finish indicated on same backing indicated for Work.

### PART 2 - PRODUCTS

#### 2.1 GYPSUM BOARD, GENERAL

- A. Size: Provide maximum lengths and widths available that will minimize joints in each area and that correspond with support system indicated.

#### 2.2 INTERIOR GYPSUM BOARD

A. Gypsum Wallboard: ASTM C1396/C1396M.

1. Thickness: 5/8 inch.
2. Long Edges: Tapered.

B. Gypsum Ceiling Board: ASTM C1396/C1396M.

1. Thickness: 5/8 inch.
2. Long Edges: Tapered.

C. Mold-Resistant Gypsum Board: ASTM C1396/C1396M. With moisture- and mold-resistant core and paper surfaces.

1. Core: 5/8 inch.
2. Long Edges: Tapered.
3. Mold Resistance: ASTM D3273, score of 10 as rated according to ASTM D3274.

## 2.3 TRIM ACCESSORIES

### A. Interior Trim: ASTM C1047.

1. Material: Galvanized or aluminum-coated steel sheet, rolled zinc, plastic, or paper-faced galvanized-steel sheet.
2. Shapes:
  - a. Cornerbead.
  - b. Bullnose bead.
  - c. LC-Bead: J-shaped; exposed long flange receives joint compound.
  - d. L-Bead: L-shaped; exposed long flange receives joint compound.
  - e. U-Bead: J-shaped; exposed short flange does not receive joint compound.
  - f. Expansion (control) joint.
  - g. Curved-Edge Cornerbead: With notched or flexible flanges.

## 2.4 JOINT TREATMENT MATERIALS

### A. General: Comply with ASTM C475/C475M.

### B. Joint Tape:

1. Interior Gypsum Board: Paper.

### C. Joint Compound for Interior Gypsum Board: For each coat, use formulation that is compatible with other compounds applied on previous or for successive coats.

## 2.5 AUXILIARY MATERIALS

### A. Provide auxiliary materials that comply with referenced installation standards and manufacturer's written instructions.

### B. Laminating Adhesive: Adhesive or joint compound recommended for directly adhering gypsum panels to continuous substrate.

### C. Steel Drill Screws: ASTM C1002 unless otherwise indicated.

1. Use screws complying with ASTM C954 for fastening panels to steel members from 0.033 to 0.112 inch thick.

## 2.6 TEXTURE FINISHES

### A. Primer: As recommended by textured finish manufacturer.

- B. Polystyrene Aggregate Ceiling Finish: Water-based, job-mixed, polystyrene aggregate finish with flame-spread and smoke-developed indexes of not more than 25 when tested according to ASTM E84.
  - 1. Texture: Fine.
- C. Aggregate Finish: Water-based, job-mixed, aggregated, drying-type texture finish for spray application.
  - 1. Texture: Light spatter.

### PART 3 - EXECUTION

#### 3.1 INSTALLATION AND FINISHING OF PANELS

- A. Examine panels before installation. Reject panels that are wet, moisture damaged, and mold damaged.
- B. Comply with ASTM C840.
- C. Isolate perimeter of gypsum board applied to non-load-bearing partitions at structural abutments. Provide 1/4- to 1/2-inch-wide spaces at these locations and trim edges with edge trim where edges of panels are exposed. Seal joints between edges and abutting structural surfaces with acoustical sealant.
- D. For trim with back flanges intended for fasteners, attach to framing with same fasteners used for panels. Otherwise, attach trim according to manufacturer's written instructions.
- E. Prefill open joints and damaged surface areas.
- F. Apply joint tape over gypsum board joints, except for trim products specifically indicated as not intended to receive tape.
- G. Gypsum Board Finish Levels: Finish panels to levels indicated below and according to ASTM C840:
  - 1. Level 1: Ceiling plenum areas, concealed areas, and where indicated.
  - 2. Level 4: At panel surfaces that will be exposed to view unless otherwise indicated.
    - a. Primer and its application to surfaces are specified in Section 09 91 23 "Interior Painting."

#### 3.2 APPLYING TEXTURE FINISHES

- A. Surface Preparation and Primer: Prepare and apply primer to gypsum panels and other surfaces receiving texture finishes. Apply primer to surfaces that are clean, dry, and smooth.

- B. Texture Finish Application: Mix and apply finish using powered spray equipment, to produce a uniform texture free of starved spots or other evidence of thin application or of application patterns.

### 3.3 PROTECTION

- A. Protect installed products from damage from weather, condensation, direct sunlight, construction, and other causes during remainder of the construction period.
- B. Remove and replace panels that are wet, moisture damaged, and mold damaged.

END OF SECTION 09 29 00

## SECTION 09 91 00 - PAINTING

### PART 1 - GENERAL

#### 1.1 SUMMARY

- A. Section Includes:
  - 1. Primers.
  - 2. Water-based finish coatings.

#### 1.2 ACTION SUBMITTALS

- A. Product Data: For each type of product.
- B. Samples: For each type of topcoat product.
- C. Product Schedule: Use same designations indicated on Drawings and in the Interior Painting Schedule to cross-reference paint systems specified in this Section. Include color designations.

#### 1.3 QUALITY ASSURANCE

- A. Mockups: Apply mockups of each paint system indicated and each color and finish selected to verify preliminary selections made under Sample submittals and to demonstrate aesthetic effects and set quality standards for materials and execution.

### PART 2 - PRODUCTS

#### 2.1 PAINT PRODUCTS, GENERAL

- A. Material Compatibility:
  - 1. Materials for use within each paint system shall be compatible with one another and substrates indicated, under conditions of service and application as demonstrated by manufacturer, based on testing and field experience.
  - 2. For each coat in a paint system, products shall be recommended in writing by topcoat manufacturers for use in paint system and on substrate indicated.
- B. Colors: Match existing building standard gray and white.

## 2.2 PRIMERS

- A. Interior/Exterior Latex Block Filler: Water-based, high-solids, emulsion coating formulated to bridge and fill porous surfaces of exterior concrete masonry units in preparation for specified subsequent coatings.
- B. Alkali-Resistant, Water-Based Primer: Water-based primer formulated for use on alkaline surfaces, such as plaster, vertical concrete, and masonry.
- C. Interior, Institutional Low-Odor/VOC Primer Sealer: Water-based primer sealer with low-odor characteristics and a VOC of less than 10 grams per liter for use on new interior plaster, concrete, and gypsum wallboard surfaces that are subsequently to be painted with latex finish coats.
- D. Alkyd Quick-Dry Primer for Metal: Corrosion-resistant, solvent-based, modified-alkyd primer; lead and chromate free; formulated for quick-drying capabilities and for use on cleaned, steel surfaces.
- E. Surface-Tolerant Metal Primer: Corrosion-resistant, solvent-based metal primer formulated for use on structural steel and metal fabrications that have been minimally prepared.
- F. Water-Based Galvanized-Metal Primer: Corrosion-resistant, acrylic primer; formulated for use on cleaned/etched, exterior, galvanized metal to prepare it for subsequent water-based coatings.

## 2.3 WATER-BASED FINISH COATS

- A. Interior, Latex, Eggshell: Pigmented, water-based paint for use on primed/sealed interior gypsum board, and on primed wood and metals.
  - 1. Gloss and Sheen Level: Manufacturer's standard eggshell finish.
- B. Interior, Water-Based Light-Industrial Coating, Eggshell: Pigmented, water-based emulsion coating for interior primed wood and metal surfaces (e.g., walls, doors, frames, trim, and sash), providing resistance to moderate abrasion and mild chemical exposure and corrosive conditions.
  - 1. Gloss and Sheen Level: Manufacturer's standard eggshell finish.
- C. Exterior, Water-Based, Light Industrial Coating, Semigloss: Corrosion-resistant, water-based, pigmented, emulsion coating formulated for resistance to blocking (sticking of two painted surfaces), water, alkalis, moderate abrasion, and mild chemical exposure and for use on exterior, primed, wood and metal surfaces.
  - 1. Gloss Level: Manufacturer's standard semigloss finish.

## PART 3 - EXECUTION

### 3.1 EXAMINATION

- A. Verify suitability of substrates, including surface conditions and compatibility, with existing finishes and primers.
- B. Proceed with coating application only after unsatisfactory conditions have been corrected.
  - 1. Application of coating indicates acceptance of surfaces and conditions.

### 3.2 PREPARATION

- A. Comply with manufacturer's written instructions and recommendations applicable to substrates and paint systems indicated.
- B. Remove hardware, covers, plates, and similar items already in place that are removable and are not to be painted. If removal is impractical or impossible because of size or weight of item, provide surface-applied protection before surface preparation and painting.
- C. After completing painting operations, use workers skilled in the trades involved to reinstall items that were removed. Remove surface-applied protection if any.

### 3.3 INSTALLATION

- A. Apply paints according to manufacturer's written instructions.
- B. Apply paints to produce surface films without cloudiness, spotting, holidays, laps, brush marks, roller tracking, runs, sags, ropiness, or other surface imperfections. Cut in sharp lines and color breaks.

### 3.4 CLEANING AND PROTECTION

- A. After completing paint application, clean spattered surfaces. Remove spattered paints by washing, scraping, or other methods. Do not scratch or damage adjacent finished surfaces.
- B. Protect work of other trades against damage from paint application. Correct damage to work of other trades by cleaning, repairing, replacing, and refinishing, as approved by Architect, and leave in an undamaged condition.
- C. At completion of construction activities of other trades, touch up and restore damaged or defaced painted surfaces.

END OF SECTION 09 91 00



## SECTION 10 28 00 - TOILET, BATH, AND LAUNDRY ACCESSORIES

### PART 1 - GENERAL

#### 1.1 SUMMARY

- A. Section Includes:
  - 1. Public-use washroom accessories.
  - 2. Under-lavatory guards.
  - 3. Custodial accessories.

#### 1.2 ACTION SUBMITTALS

- A. Product Data: For each type of product.
- B. Delegated Design Submittal: For grab bars.
  - 1. Include structural design calculations indicating compliance with specified structural-performance requirements.

#### 1.3 INFORMATIONAL SUBMITTALS

- A. Sample warranties.

#### 1.4 CLOSEOUT SUBMITTALS

- A. Maintenance data.

#### 1.5 WARRANTY

- A. Manufacturer's Special Warranty for Mirrors: Manufacturer agrees to repair or replace mirrors that fail in materials or workmanship within specified warranty period.

### PART 2 - PRODUCTS

#### 2.1 PERFORMANCE REQUIREMENTS

- A. Electrical Components, Devices, and Accessories: Listed and labeled as defined in NFPA 70, by a qualified testing agency, and marked for intended location and application.

- B. Structural Performance: Design accessories and fasteners to comply with the following requirements:
  - 1. Grab Bars: Installed units are able to resist 250 lbf concentrated load applied in any direction and at any point.

## 2.2 PUBLIC-USE WASHROOM ACCESSORIES

- A. Toilet Tissue (Roll) Dispenser:
  - 1. Description: Double-roll dispenser.
  - 2. Mounting: Surface mounted.
  - 3. Capacity: Designed for 4-1/2- or 5-inch diameter tissue rolls.
  - 4. Material and Finish: Stainless steel, ASTM A480/A480M No. 4 finish (satin).
- B. Combination Towel (Folded) Dispenser/Waste Receptacle:
  - 1. Description: Combination unit for dispensing C-fold or multifold towels, with removable waste receptacle.
  - 2. Mounting: Semirecessed.
    - a. Designed for nominal 4-inch wall depth.
  - 3. Material and Finish: Stainless steel, ASTM A480/A480M No. 4 finish (satin).
  - 4. Liner: Reusable, vinyl waste-receptacle liner.
  - 5. Lockset: Tumbler type for towel-dispenser compartment.
- C. Soap Dispenser:
  - 1. Description: Designed for manual operation and dispensing soap in liquid or lotion form.
  - 2. Mounting: Vertically oriented, surface mounted.
  - 3. Lockset: Tumbler type.
  - 4. Refill Indicator: Window type.
- D. Grab Bar:
  - 1. Mounting: Flanges with concealed fasteners.
  - 2. Material: Stainless steel, 0.05 inch thick.
    - a. Finish: Smooth, ASTM A480/A480M No. 4 finish (satin).
  - 3. Outside Diameter: 1-1/2 inches.
- E. Sanitary-Napkin Disposal Unit:
  - 1. Mounting: Surface mounted.
  - 2. Door or Cover: Self-closing, disposal-opening cover.
  - 3. Receptacle: Removable.
  - 4. Material and Finish: Stainless steel, ASTM A480/A480M No. 4 finish (satin).

F. Mirror Unit:

1. Frame: Stainless steel channel.
  - a. Corners: Manufacturer's standard.
2. Size: 24 inch by 36 inch.
3. Hangers: Manufacturer's standard rigid, tamper and theft resistant.

2.3 UNDERLAVATORY GUARDS

A. Under lavatory Guard:

1. Description: Insulating pipe covering for supply and drain piping assemblies that prevents direct contact with and burns from piping; allow service access without removing coverings.
2. Material and Finish: Antimicrobial, molded plastic, white.

2.4 CUSTODIAL ACCESSORIES

A. Custodial Mop and Broom Holder:

1. Description: Unit with shelf, hooks, holders, and rod suspended beneath shelf.
2. Length: 36 inches.
3. Hooks: Four.
4. Mop/Broom Holders: Three, spring-loaded, rubber hat, cam type.
5. Material and Finish: Stainless steel, ASTM A480/A480M No. 4 finish (satin).
  - a. Shelf: Not less than nominal 0.05-inch-thick stainless steel.
  - b. Rod: Approximately 1/4-inch-diameter stainless steel.

B. Custodial Paper Towel (Folded) Dispenser:

1. Mounting: Surface mounted.
2. Material and Finish: Stainless steel, ASTM A480/A480M No. 4 finish (satin).
3. Lockset: Tumbler type.

C. Custodial Soap Dispenser:

1. Description: Designed for manual operation and dispensing soap in liquid or lotion form.
2. Mounting: Vertically oriented, surface mounted.
3. Refill Indicator: Window type.

2.5 FABRICATION

- A. Keys: Provide universal keys for internal access to accessories for servicing and resupplying. Provide keys to Owner's representative.

PART 3 - EXECUTION

3.1 INSTALLATION

- A. Install accessories according to manufacturers' written instructions, using fasteners appropriate to substrate indicated and recommended by unit manufacturer. Install units level, plumb, and firmly anchored in locations and at heights indicated.
  - 1. Remove temporary labels and protective coatings.
- B. Grab Bars: Install to comply with specified structural-performance requirements.

END OF SECTION 10 28 00

## SECTION 10 44 16 - FIRE EXTINGUISHERS

### PART 1 - GENERAL

#### 1.1 SUMMARY

- A. Section includes portable, hand-carried fire extinguishers and mounting brackets for fire extinguishers.

#### 1.2 PREINSTALLATION MEETINGS

- A. Preinstallation Conference: Conduct conference at Project site.

#### 1.3 ACTION SUBMITTALS

- A. Product Data: For each type of product.

#### 1.4 INFORMATIONAL SUBMITTALS

- A. Warranty: Sample of special warranty.

#### 1.5 CLOSEOUT SUBMITTALS

- A. Operation and maintenance data.

#### 1.6 WARRANTY

- A. Special Warranty: Manufacturer's standard form in which manufacturer agrees to repair or replace fire extinguishers that fail in materials or workmanship within specified warranty period.

### PART 2 - PRODUCTS

#### 2.1 PERFORMANCE REQUIREMENTS

- A. NFPA Compliance: Fabricate and label fire extinguishers to comply with NFPA 10, "Portable Fire Extinguishers."
- B. Fire Extinguishers: Listed and labeled for type, rating, and classification by an independent testing agency acceptable to authorities having jurisdiction.

## 2.2 PORTABLE, HAND-CARRIED FIRE EXTINGUISHERS

- A. Fire Extinguishers: Type, size, and capacity for each mounting bracket indicated.
  - 1. Instruction Labels: Include pictorial marking system complying with NFPA 10, Appendix B.
- B. Multipurpose Dry-Chemical Type: UL-rated 2A:10B:C nominal capacity, with monoammonium phosphate-based dry chemical in manufacturer's standard enameled container.

## 2.3 MOUNTING BRACKETS

- A. Mounting Brackets: Manufacturer's standard steel, designed to secure fire extinguisher to wall or structure, of sizes required for types and capacities of fire extinguishers indicated, with plated or red baked-enamel finish.
- B. Identification: Lettering complying with authorities having jurisdiction for letter style, size, spacing, and location. Locate as indicated by Architect.
  - 1. Identify bracket-mounted fire extinguishers with the words "FIRE EXTINGUISHER" in red letter decals applied to mounting surface.

## PART 3 - EXECUTION

### 3.1 INSTALLATION

- A. Examine fire extinguishers for proper charging and tagging.
  - 1. Remove and replace damaged, defective, or undercharged fire extinguishers.
- B. Install fire extinguishers and mounting brackets in locations indicated and in compliance with requirements of authorities having jurisdiction.
  - 1. Mounting Brackets: Top of fire extinguisher to be at 42 inches above finished floor.
- C. Mounting Brackets: Fasten mounting brackets to surfaces, square and plumb, at locations.

END OF SECTION 10 44 16

## SECTION 13 34 19 - METAL BUILDING SYSTEMS

### PART 1 - GENERAL

#### 1.1 SUMMARY

- A. Section Includes:
  - 1. Structural-steel framing.
  - 2. Metal roof panels.
  - 3. Metal wall panels.
  - 4. Metal soffit panels.
  - 5. Thermal insulation.
  - 6. Accessories.

#### 1.2 PREINSTALLATION MEETINGS

- A. Preinstallation Conference: Conduct conference at Project site.

#### 1.3 ACTION SUBMITTALS

- A. Product Data: For each type of metal building system component.
- B. Shop Drawings: Indicate components by others. Include full building plan, elevations, sections, details and attachments to other work.
- C. Samples: For units with factory-applied finishes.
- D. Delegated-Design Submittal: For metal building systems.
  - 1. Include analysis data indicating compliance with performance requirements and design data signed and sealed by the qualified professional engineer responsible for their preparation.

#### 1.4 INFORMATIONAL SUBMITTALS

- A. Welding certificates.
- B. Letter of Design Certification: Signed and sealed by a qualified professional engineer. Include the following:
  - 1. Name and location of Project.
  - 2. Order number.
  - 3. Name of manufacturer.
  - 4. Name of Contractor.
  - 5. Building dimensions including width, length, height, and roof slope.

6. Indicate compliance with AISC standards for hot-rolled steel and AISI standards for cold-rolled steel, including edition dates of each standard.
7. Governing building code and year of edition.
8. Design Loads: Include dead load, roof live load, collateral loads, roof snow load, deflection, wind loads/speeds and exposure, seismic design category or effective peak velocity-related acceleration/peak acceleration, and auxiliary loads (cranes).
9. Load Combinations: Indicate that loads were applied acting simultaneously with concentrated loads, according to governing building code.
10. Building-Use Category: Indicate category of building use and its effect on load importance factors.

- C. Material test reports.
- D. Source quality-control reports.
- E. Field quality-control reports.
- F. Sample warranties.

#### 1.5 CLOSEOUT SUBMITTALS

- A. Maintenance data.

#### 1.6 QUALITY ASSURANCE

- A. Manufacturer Qualifications: A qualified manufacturer.
  1. Accreditation: Manufacturer's facility accredited according to the International Accreditation Service's AC472, "Accreditation Criteria for Inspection Programs for Manufacturers of Metal Building Systems."
  2. Engineering Responsibility: Preparation of comprehensive engineering analysis and Shop Drawings by a professional engineer who is legally qualified to practice in jurisdiction where Project is located.
- B. Erector Qualifications: An experienced erector who specializes in erecting and installing work similar in material, design, and extent to that indicated for this Project and who is acceptable to manufacturer.
- C. Welding Qualifications: Qualify procedures and personnel according to the following:
  1. AWS D1.1/D1.1M, "Structural Welding Code - Steel."
  2. AWS D1.3, "Structural Welding Code - Sheet Steel."

#### 1.7 WARRANTY

- A. Special Warranty on Metal Panel Finishes: Manufacturer agrees to repair finish or replace metal panels that show evidence of deterioration of factory-applied finishes within specified warranty period.



- B. Manufacturer shall warranty installed system for the periods described herein, starting from Date of Substantial Completion or ninety days from delivery, whichever comes first, against all the conditions indicated below. When notified in writing from Owner, manufacturer/installer shall, promptly and without inconvenience and cost to Owner, correct said deficiencies.
1. Materials and Workmanship Warranty:
    - a. Warranty Period: 5 years, premium.
  2. No Dollar Limit (NDL) Material and Workmanship Warranty:
    - a. Warranty Period: 5 years, premium.
  3. Panel Rib Standard Weathertight Warranty:
    - a. Warranty Period: 10 years, standard.
  4. No Dollar Limit (NDL) Weathertight Endorsement:
    - a. Warranty Period: 20 years.
  5. Structural NDL Endorsement:
    - a. Warranty Period: 20 years.
  6. Finish Warranty:
  7. Finish coating shall not peel, blister, chip, crack or check in finish, and shall not chalk in excess of 8 numerical ratings when measured in accordance with ASTM D 4214.
  8. Finish coating shall not change color or fade in excess of 5 NBS units as determined by ASTM D 2244.
    - a. Panel finish: 25 years.
  9. Performance Warranty: Furnish written warranty, stating sheet metal roofing system and flashing (flashing under premium warranty only) under this Section will be maintained in watertight condition and defects resulting from the following items will be corrected without cost to Owner for a period of 10 or 20 years.
  10. Faulty workmanship.
  11. Defective materials including sealants and fasteners.
  12. Water infiltration.

## PART 2 - PRODUCTS

### 2.1 MANUFACTURERS

- A. Varco-Pruden Buildings; a division of BlueScope Buildings North America, Inc.
1. 3200 Players Club Circle, Memphis TN 38125; [www.varcopruden.com](http://www.varcopruden.com)

## 2.2 PERFORMANCE REQUIREMENTS

- A. Delegated Design: Engage a qualified professional engineer, as defined in Section 01 40 00 "Quality Requirements," to design metal building system.
- B. Structural Performance: Metal building systems shall withstand the effects of gravity loads and the following loads and stresses within limits and under conditions indicated according to procedures in MBMA's "Metal Building Systems Manual."
  - 1. Design Loads: As indicated on Drawings
  - 2. Deflection and Drift Limits: Design metal building system assemblies to withstand serviceability design loads without exceeding deflections and drift limits recommended in AISC Steel Design Guide No. 3 "Serviceability Design Considerations for Steel Buildings."
- C. Seismic Performance: Metal building system shall withstand the effects of earthquake motions determined according to ASCE/SEI 7.
- D. Thermal Movements: Allow for thermal movements from ambient and surface temperature changes by preventing buckling, opening of joints, overstressing of components, failure of joint sealants, failure of connections, and other detrimental effects. Base calculations on surface temperatures of materials due to both solar heat gain and nighttime-sky heat loss.
- E. Fire-Resistance Ratings: Where assemblies are indicated to have a fire-resistance rating, provide metal panel assemblies identical to those of assemblies tested for fire resistance per ASTM E119 or ASTM E108 by a qualified testing agency. Identify products with appropriate markings of applicable testing agency.
  - 1. Indicate design designations from UL's "Fire Resistance Directory," FM Global's "Approval Guide," or from the listings of another qualified testing agency.
- F. Structural Performance for Metal Roof and Wall Panels: Provide metal panel systems capable of withstanding the effects of the following loads, based on testing according to ASTM E1592:
  - 1. Wind Loads: As indicated on Drawings.
- G. Air Infiltration for Metal Roof Panels: Air leakage of not more than 0.06 cfm/sq. ft. when tested according to ASTM E1680 at the following test-pressure difference:
  - 1. Test-Pressure Difference: 1.57 lbf/sq. ft.
- H. Air Infiltration for Metal Wall Panels: Air leakage of not more than 0.06 cfm/sq. ft. when tested according to ASTM E283 at the following test-pressure difference:
  - 1. Test-Pressure Difference: 1.57 lbf/sq. ft.
- I. Water Penetration for Metal Roof Panels: No water penetration when tested according to ASTM E1646 at the following test-pressure difference:

1. Test-Pressure Difference: 6.24 lbf/sq. ft.
- J. Water Penetration for Metal Wall Panels: No water penetration when tested according to ASTM E331 at the following test-pressure difference:
  1. Test-Pressure Difference: 2.86 lbf/sq. ft.
- K. Wind-Uplift Resistance: Provide metal roof panel assemblies that comply with UL 580 for wind-uplift-resistance class indicated.
  1. Uplift Rating: UL 90.
- L. Thermal Performance for Opaque Elements: Provide the following maximum U-factors and minimum R-values when tested according to ASTM C1363 or ASTM C518:
  1. Roof:
    - a. U-Factor: .065
    - b. R-Value: R-19
  2. Walls:
    - a. U-Factor: .084
    - b. R-Value: R-19.

## 2.3 STRUCTURAL-STEEL FRAMING

- A. Structural Steel: Comply with AISC 360, "Specification for Structural Steel Buildings."
- B. Bolted Connections: Comply with RCSC's "Specification for Structural Joints Using High-Strength Bolts."
- C. Cold-Formed Steel: Comply with AISI's "North American Specification for the Design of Cold-Formed Steel Structural Members" for design requirements and allowable stresses.
- D. Primary Framing: Manufacturer's standard primary-framing system, designed to withstand required loads and specified requirements. Primary framing includes transverse and lean-to frames; rafters and rake beams; sidewall, intermediate, end-wall, and corner columns; and wind bracing.
  1. General: Provide frames with attachment plates, bearing plates, and splice members. Factory drill for field-bolted assembly. Provide frame span and spacing indicated.
  2. Frame Configuration: Single gable.
  3. Exterior Column: Uniform depth.
  4. Rafter: Tapered.
- E. End-Wall Framing: Manufacturer's standard primary end-wall framing fabricated for field-bolted assembly to comply with the following:

- F. Secondary Framing: Manufacturer's standard secondary framing, including purlins, girts, eave struts, flange bracing, base members, gable angles, clips, headers, jambs, and other miscellaneous structural members. Unless otherwise indicated, fabricate framing from either cold-formed, structural-steel sheet or roll-formed, metallic-coated steel sheet, prepainted with coil coating, to comply with the following:
- G. Anchor Rods: Headed anchor rods as indicated in Anchor Rod Plan for attachment of metal building to foundation.

## 2.4 METAL ROOF PANELS

- A. Exposed Fastener, Tapered-Rib, Metal Roof Panels: Formed with raised, trapezoidal major ribs and intermediate stiffening ribs symmetrically spaced between major ribs; designed to be installed by lapping side edges of adjacent panels and mechanically attaching panels to supports using exposed fasteners in side laps.
  - 1. Material: Zinc-coated (galvanized) or aluminum-zinc alloy-coated steel sheet, 0.018-inch nominal uncoated steel thickness. Prepainted by the coil-coating process to comply with ASTM A755/A755M.
    - a. Exterior Finish: Three-coat fluoropolymer.
    - b. Color: As selected by Architect from manufacturer's full range to match existing.
  - 2. Major-Rib Spacing: 12 inches, match existing o.c.
  - 3. Panel Coverage: 36 inches.
  - 4. Panel Height: 1-3/16 inches; match existing.

## 2.5 METAL WALL PANELS

- A. Semi-Concealed-Fastener, Flush-Profile, Metal Wall Panels: Formed with vertical panel edges and a single wide recess, centered between panel edges; with flush joint between panels; with 1-inch-wide flange for attaching interior finish; designed to be installed by lapping and interconnecting side edges of adjacent panels and mechanically attaching through panel to supports using concealed fasteners.
  - 1. Material: Zinc-coated (galvanized) or aluminum-zinc alloy-coated steel sheet, 0.024-inch nominal uncoated steel thickness. Prepainted by the coil-coating process to comply with ASTM A755/A755M.
    - a. Exterior Finish: Fluoropolymer.
    - b. Color: As selected by Architect from manufacturer's full range to match existing.
  - 2. Panel Coverage: 36 inches.
  - 3. Panel Height: 1-3/16 inches.

## 2.6 METAL SOFFIT PANELS

- A. General: Provide factory-formed metal soffit panels designed to be installed by lapping and interconnecting side edges of adjacent panels and mechanically attaching through panel to supports using concealed fasteners[ and factory-applied sealant] in side laps. Include accessories required for weathertight installation.
- B. Metal Soffit Panels: Match profile and material of metal roof panels.
  - 1. Finish: Match finish and color of metal wall panels.

## 2.7 THERMAL INSULATION

- A. Faced Metal Building Insulation: ASTM C991, Type II, glass-fiber-blanket insulation; 0.5-lb/cu. ft. density; 2-inch-wide, continuous, vapor-tight edge tabs; with a flame-spread index of 25 or less.
- B. Unfaced Metal Building Insulation: ASTM C991, Type I, or NAIMA 202, glass-fiber-blanket insulation; 0.5-lb/cu. ft. density; 2-inch-wide, continuous, vapor-tight edge tabs; with a flame-spread index of 25 or less.
- C. Retainer Strips: For securing insulation between supports, 0.025-inch nominal-thickness, formed, metallic-coated steel or PVC retainer clips colored to match insulation facing.
- D. Vapor-Retarder Facing: ASTM C1136, with permeance not greater than 0.02 perm when tested according to ASTM E96/E96M, Desiccant Method.

## 2.8 ACCESSORIES

- A. General: Provide accessories as standard with metal building system manufacturer and as specified. Fabricate and finish accessories at the factory to greatest extent possible, by manufacturer's standard procedures and processes. Comply with indicated profiles and with dimensional and structural requirements.
  - 1. Form exposed sheet metal accessories that are without excessive oil-canning, buckling, and tool marks and that are true to line and levels indicated, with exposed edges folded back to form hems.
- B. Roof Panel Accessories: Provide components required for a complete metal roof panel assembly including copings, fasciae, corner units, ridge closures, clips, sealants, gaskets, fillers, closure strips, and similar items. Match material and finish of metal roof panels unless otherwise indicated.
- C. Wall Panel Accessories: Provide components required for a complete metal wall panel assembly including copings, fasciae, mullions, sills, corner units, clips, sealants, gaskets, fillers, closure strips, and similar items. Match material and finish of metal wall panels unless otherwise indicated.

- D. Flashing and Trim: Zinc-coated (galvanized) or aluminum-zinc alloy-coated steel sheet, 0.018-inch nominal uncoated steel thickness, prepainted with coil coating; finished to match adjacent metal panels.
- E. Gutters: Zinc-coated (galvanized) or aluminum-zinc alloy-coated steel sheet, 0.018-inch nominal uncoated steel thickness, prepainted with coil coating; finished to match roof fascia and rake trim. Match profile of gable trim, complete with end pieces, outlet tubes, and other special pieces as required. Fabricate in minimum 96-inch-long sections, sized according to SMACNA's "Architectural Sheet Metal Manual."
  - 1. Gutter Supports: Fabricated from same material and finish as gutters.
- F. Downspouts: Zinc-coated (galvanized) or aluminum-zinc alloy-coated steel sheet, 0.018-inch nominal uncoated steel thickness, prepainted with coil coating; finished to match metal wall panels. Fabricate in minimum 10-foot-long sections, complete with formed elbows and offsets.
  - 1. Mounting Straps: Fabricated from same material and finish as gutters.
- G. Pipe Flashing: Premolded, EPDM pipe collar with flexible aluminum ring bonded to base.

## 2.9 FABRICATION

- A. General: Design components and field connections required for erection to permit easy assembly.
  - 1. Mark each piece and part of the assembly to correspond with previously prepared erection drawings, diagrams, and instruction manuals.
  - 2. Fabricate structural framing to produce clean, smooth cuts and bends. Punch holes of proper size, shape, and location. Members shall be free of cracks, tears, and ruptures.
- B. Tolerances: Comply with MBMA's "Metal Building Systems Manual" for fabrication and erection tolerances.
- C. Primary Framing: Shop fabricate framing components to indicated size and section, with baseplates, bearing plates, stiffeners, and other items required for erection welded into place. Cut, form, punch, drill, and weld framing for bolted field assembly.
- D. Secondary Framing: Shop fabricate framing components to indicated size and section by roll forming or break forming, with baseplates, bearing plates, stiffeners, and other plates required for erection welded into place. Cut, form, punch, drill, and weld secondary framing for bolted field connections to primary framing.
- E. Metal Panels: Fabricate and finish metal panels at the factory to greatest extent possible, by manufacturer's standard procedures and processes, as necessary to fulfill indicated performance requirements. Comply with indicated profiles and with dimensional and structural requirements.

1. Provide panel profile, including major ribs and intermediate stiffening ribs, if any, for full length of metal panel.

### PART 3 - EXECUTION

#### 3.1 ERECTION OF STRUCTURAL FRAMING

- A. Erect metal building system according to manufacturer's written instructions and drawings.
- B. Do not field cut, drill, or alter structural members without written approval from metal building system manufacturer's professional engineer.
- C. Set structural framing accurately in locations and to elevations indicated, according to AISC specifications referenced in this Section. Maintain structural stability of frame during erection.
- D. Base and Bearing Plates: Clean concrete- and masonry-bearing surfaces of bond-reducing materials, and roughen surfaces prior to setting plates. Clean bottom surface of plates.
  1. Set plates for structural members on wedges, shims, or setting nuts as required.
  2. Tighten anchor rods after supported members have been positioned and plumbed. Do not remove wedges or shims but, if protruding, cut off flush with edge of plate before packing with grout.
  3. Promptly pack grout solidly between bearing surfaces and plates so no voids remain. Neatly finish exposed surfaces; protect grout and allow to cure. Comply with manufacturer's written installation instructions for shrinkage-resistant grouts.
- E. Align and adjust structural framing before permanently fastening. Before assembly, clean bearing surfaces and other surfaces that will be in permanent contact with framing. Perform necessary adjustments to compensate for discrepancies in elevations and alignment.
  1. Level and plumb individual members of structure.
- F. Primary Framing and End Walls: Erect framing level, plumb, rigid, secure, and true to line. Level baseplates to a true even plane with full bearing to supporting structures, set with double-nutted anchor bolts. Use grout to obtain uniform bearing and to maintain a level base-line elevation. Moist-cure grout for not less than seven days after placement.
  1. Make field connections using high-strength bolts installed according to RCSC's "Specification for Structural Joints Using High-Strength Bolts" for bolt type and joint type specified.
    - a. Joint Type: Snug tightened or pretensioned as required by manufacturer.

- G. Secondary Framing: Erect framing level, plumb, rigid, secure, and true to line. Field bolt secondary framing to clips attached to primary framing.
1. Provide rake or gable purlins with tight-fitting closure channels and fasciae.
  2. Locate and space wall girts to suit openings such as doors and windows.
  3. Provide supplemental framing at entire perimeter of openings, including doors, windows, ventilators, and other penetrations of roof and walls.

Retain "Steel Joists" Paragraph below if steel joist purlins are required; otherwise, delete.

- H. Bracing: Install bracing in roof and sidewalls where indicated on erection drawings.
1. Tighten rod and cable bracing to avoid sag.
  2. Locate interior end-bay bracing only where indicated.
- I. Framing for Openings: Provide shapes of proper design and size to reinforce openings and to carry loads and vibrations imposed, including equipment furnished under mechanical and electrical work. Securely attach to structural framing.
- J. Erection Tolerances: Maintain erection tolerances of structural framing within AISC 303.

### 3.2 METAL PANEL INSTALLATION, GENERAL

- A. General: Anchor metal panels and other components of the Work securely in place, with provisions for thermal and structural movement.
1. Field cut metal panels as required for doors, windows, and other openings. Cut openings as small as possible, neatly to size required, and without damage to adjacent metal panel finishes.
    - a. Field cutting of metal panels by torch is not permitted unless approved in writing by manufacturer.
  2. Install metal panels perpendicular to structural supports unless otherwise indicated.
  3. Flash and seal metal panels with weather closures at perimeter of openings and similar elements. Fasten with self-tapping screws.
  4. Locate and space fastenings in uniform vertical and horizontal alignment.
  5. Locate metal panel splices over structural supports with end laps in alignment.
  6. Lap metal flashing over metal panels to allow moisture to run over and off the material.
- B. Lap-Seam Metal Panels: Install screw fasteners using power tools with controlled torque adjusted to compress EPDM washers tightly without damage to washers, screw threads, or metal panels. Install screws in predrilled holes.
1. Arrange and nest side-lap joints so prevailing winds blow over, not into, lapped joints. Lap ribbed or fluted sheets one full rib corrugation. Apply metal panels and



associated items for neat and weathertight enclosure. Avoid "panel creep" or application not true to line.

- C. Metal Protection: Where dissimilar metals contact each other or corrosive substrates, protect against galvanic action by painting contact surfaces with corrosion-resistant coating, by applying rubberized-asphalt underlayment to each contact surface, or by other permanent separation as recommended by metal roof panel manufacturer.
- D. Joint Sealers: Install gaskets, joint fillers, and sealants where indicated and where required for weatherproof performance of metal panel assemblies. Provide types of gaskets, fillers, and sealants indicated; or, if not indicated, provide types recommended by metal panel manufacturer.
  - 1. Seal metal panel end laps with double beads of tape or sealant the full width of panel. Seal side joints where recommended by metal panel manufacturer.
  - 2. Prepare joints and apply sealants

### 3.3 METAL ROOF PANEL INSTALLATION

- A. General: Provide metal roof panels of full length from eave to ridge unless otherwise indicated or restricted by shipping limitations.
  - 1. Install ridge caps as metal roof panel work proceeds.
  - 2. Flash and seal metal roof panels with weather closures at eaves and rakes. Fasten with self-tapping screws.
- B. Lap-Seam Metal Roof Panels: Fasten metal roof panels to supports with exposed fasteners at each lapped joint, at location and spacing recommended by manufacturer.
  - 1. Provide metal-backed sealing washers under heads of exposed fasteners bearing on weather side of metal roof panels.
  - 2. Provide sealant tape at lapped joints of metal roof panels and between panels and protruding equipment, vents, and accessories.
  - 3. Apply a continuous ribbon of sealant tape to weather-side surface of fastenings on end laps and on side laps of nesting-type metal panels, on side laps of ribbed or fluted metal panels, and elsewhere as needed to make metal panels weatherproof to driving rains.
  - 4. At metal panel splices, nest panels with minimum 6-inch end lap, sealed with butyl-rubber sealant and fastened together by interlocking clamping plates.
- C. Metal Fascia Panels: Align bottom of metal panels and fasten with blind rivets, bolts, or self-drilling or self-tapping screws. Flash and seal metal panels with weather closures where fasciae meet soffits, along lower panel edges, and at perimeter of all openings.

### 3.4 METAL WALL PANEL INSTALLATION

- A. General: Install metal wall panels in orientation, sizes, and locations indicated on Drawings. Install panels perpendicular to girts, extending full height of building, unless

otherwise indicated. Anchor metal wall panels and other components of the Work securely in place, with provisions for thermal and structural movement.

1. Unless otherwise indicated, begin metal panel installation at corners with center of rib lined up with line of framing.
  2. Shim or otherwise plumb substrates receiving metal wall panels.
  3. When two rows of metal panels are required, lap panels 4 inches minimum.
  4. When building height requires two rows of metal panels at gable ends, align lap of gable panels over metal wall panels at eave height.
  5. Rigidly fasten base end of metal wall panels and allow eave end free movement for thermal expansion and contraction. Pre-drill panels.
  6. Flash and seal metal wall panels with weather closures at eaves and rakes, and at perimeter of all openings. Fasten with self-tapping screws.
  7. Install screw fasteners in pre-drilled holes.
  8. Install flashing and trim as metal wall panel work proceeds.
  9. Apply elastomeric sealant continuously between metal base channel (sill angle) and concrete, and elsewhere as indicated on Drawings; if not indicated, as necessary for waterproofing.
  10. Align bottom of metal wall panels and fasten with blind rivets, bolts, or self-drilling or self-tapping screws.
  11. Provide weatherproof escutcheons for pipe and conduit penetrating exterior walls.
- B. Metal Wall Panels: Install metal wall panels on exterior side of girts. Attach metal wall panels to supports with fasteners as recommended by manufacturer.

### 3.5 METAL SOFFIT PANEL INSTALLATION

- A. Provide metal soffit panels the full width of soffits. Install panels perpendicular to support framing.
- B. Flash and seal metal soffit panels with weather closures where panels meet walls and at perimeter of all openings.

### 3.6 THERMAL INSULATION INSTALLATION

- A. General: Install insulation concurrently with metal panel installation, in thickness indicated to cover entire surface, according to manufacturer's written instructions.
1. Set vapor-retarder-faced units with vapor retarder toward warm side of construction unless otherwise indicated. Do not obstruct ventilation spaces except for firestopping.
  2. Tape joints and ruptures in vapor retarder, and seal each continuous area of insulation to the surrounding construction to ensure airtight installation.
  3. Install blankets straight and true in one-piece lengths. Install vapor retarder over insulation, with both sets of facing tabs sealed, to provide a complete vapor retarder.
- B. Blanket Roof Insulation: Comply with the following installation method:

1. Over-Purlin-with-Spacer-Block Installation: Extend insulation and vapor retarder over and perpendicular to top flange of secondary framing. Install layer of filler insulation over first layer to fill space formed by metal roof panel standoffs. Hold in place by panels fastened to standoffs.
    - a. Thermal Spacer Blocks: Where metal roof panels attach directly to purlins, install thermal spacer blocks.
  2. Retainer Strips: Install retainer strips at each longitudinal insulation joint, straight and taut, nesting with secondary framing to hold insulation in place.
- C. Blanket Wall Insulation: Extend insulation and vapor retarder over and perpendicular to top flange of secondary framing. Hold in place by metal wall panels fastened to secondary framing.
1. Retainer Strips: Install retainer strips at each longitudinal insulation joint, straight and taut, nesting with secondary framing to hold insulation in place.

### 3.7 ACCESSORY INSTALLATION

- A. General: Install accessories with positive anchorage to building and weathertight mounting, and provide for thermal expansion. Coordinate installation with flashings and other components.
1. Install components required for a complete metal roof panel assembly, including trim, copings, ridge closures, seam covers, flashings, sealants, gaskets, fillers, closure strips, and similar items.
  2. Install components for a complete metal wall panel assembly, including trim, copings, corners, seam covers, flashings, sealants, gaskets, fillers, closure strips, and similar items.
  3. Where dissimilar metals contact each other or corrosive substrates, protect against galvanic action by painting contact surfaces with corrosion-resistant coating, by applying rubberized-asphalt underlayment to each contact surface, or by other permanent separation as recommended by manufacturer.
- B. Flashing and Trim: Comply with performance requirements, manufacturer's written installation instructions, and SMACNA's "Architectural Sheet Metal Manual." Provide concealed fasteners where possible, and set units true to line and level. Install work with laps, joints, and seams that will be permanently watertight and weather resistant.
1. Install exposed flashing and trim that is without excessive oil-canning, buckling, and tool marks and that is true to line and levels indicated, with exposed edges folded back to form hems. Install sheet metal flashing and trim to fit substrates and to result in waterproof and weather-resistant performance.
  2. Expansion Provisions: Provide for thermal expansion of exposed flashing and trim. Space movement joints at a maximum of 10 feet with no joints allowed within 24 inches of corner or intersection. Where lapped or bayonet-type expansion provisions cannot be used or would not be sufficiently weather resistant and waterproof, form expansion joints of intermeshing hooked flanges, not less than 1 inch deep, filled with mastic sealant (concealed within joints).

- C. Gutters: Join sections with riveted-and-soldered or lapped-and-sealed joints. Attach gutters to eave with gutter hangers spaced as required for gutter size, but not more than 36 inches o.c. using manufacturer's standard fasteners. Provide end closures and seal watertight with sealant. Provide for thermal expansion.
- D. Downspouts: Join sections with 1-1/2-inch telescoping joints. Provide fasteners designed to hold downspouts securely 1 inch away from walls; locate fasteners at top and bottom and at approximately 60 inches o.c. in between.
  - 1. Tie downspouts to underground drainage system indicated.
- E. Pipe Flashing: Form flashing around pipe penetration and metal roof panels. Fasten and seal to panel as recommended by manufacturer.

### 3.8 FIELD QUALITY CONTROL

- A. Product will be considered defective if it does not pass tests and inspections.
- B. Prepare test and inspection reports.

END OF SECTION 13 34 19

## SECTION 22 14 23 - STORM DRAINAGE PIPING SPECIALTIES

### PART 1 - GENERAL

#### 1.1 SUMMARY

A. Section Includes:

1. Trench drains.
2. Floor drains.

#### 1.2 ACTION SUBMITTALS

A. Product Data: For each type of product.

#### 1.3 QUALITY ASSURANCE

A. Drainage piping specialties shall bear label, stamp, or other markings of specified testing agency.

### PART 2 - PRODUCTS

#### 2.1 TRENCH DRAINS

A. Trench Drains:

1. Standard: ASME A112.6.3.
2. Body Material: Cast iron or precast polymer as designated by MEP provider.
3. Flange: Anchored or as required by selected manufacturer.
4. Clamping Device: As required by selected manufacturer.
5. Outlet: Bottom.
6. Grate Material: Galvanized steel.
7. Dimensions of Frame and Grate: 20-foot length, 6-inch grate.
8. Top-Loading Classification: Heavy Duty.

#### 2.2 FLOOR DRAINS

A. Floor Drains:

1. Standard: ASME A112.6.3.
2. Body Material: PVC.
3. Clamping Device: Cast iron clamping collar.
4. Outlet: Bottom.
5. Grate Material: Nickel Bronze.

6. Dimensions of Frame and Grate: 5 inch diameter.
7. Top-Loading Classification: Medium Duty.

### PART 3 - EXECUTION

#### 3.1 INSTALLATION

- A. Install drains at low points of surface areas to be drained. Set grates of drains flush with finished surface unless otherwise indicated.
- B. Comply with requirements for piping specified in applicable plumbing codes.

#### 3.2 INSTALLATION OF FLASHING

- A. Fabricate flashing from single piece of metal unless large pans, sumps, or other drainage shapes are required.
- B. Install sheet flashing on pipes, sleeves, and specialties passing through or embedded in floors and roofs with waterproof membrane.
- C. Set flashing on floors and roofs in solid coating of bituminous cement.
- D. Secure flashing into sleeve and specialty clamping ring or device.

#### 3.3 PROTECTION

- A. Protect drains during remainder of construction period to avoid clogging with dirt or debris and to prevent damage from traffic or construction work.
- B. Place plugs in ends of uncompleted piping at end of each day or when work stops.

END OF SECTION 22 14 23

## SECTION 22 42 13.13 - COMMERCIAL WATER CLOSETS

### PART 1 - GENERAL

#### 1.1 SUMMARY

A. Section Includes:

1. Floor-mounted, bottom-outlet water closets.
2. Toilet seats.
3. Supports.

#### 1.2 ACTION SUBMITTALS

- A. Product Data: For each type of product.
- B. Shop Drawings: Include diagrams for power and control wiring.

#### 1.3 CLOSEOUT SUBMITTALS

- A. Operation and maintenance data.

### PART 2 - PRODUCTS

#### 2.1 PERFORMANCE REQUIREMENTS

A. Standards:

1. Comply with ASME A112.19.2/CSA B45.1 for water closets.
2. Comply with ASME A112.19.5/CSA B45.15 for flush valves and spuds for water closets and tanks.
3. Comply with ASSE 1037/ASME A112.1037/CSA B125.37 for flush valves.
4. Comply with IAMPO/ANSI Z124.5 for water-closet (toilet) seats.
5. Comply with ASME A112.6.1M for water-closet supports.
6. Comply with ICC A117.1 for ADA-compliant water closets.
7. Comply with ASTM A1045 for flexible PVC gaskets used in connection of vitreous china water closets to sanitary drainage systems.
8. Comply with ASME A112.4.3 for plastic fittings used in connection of vitreous china water closets to sanitary drainage systems.

#### 2.2 FLOOR-MOUNTED, BOTTOM-OUTLET WATER CLOSETS

- A. Water Closets - Floor Mounted, Bottom Outlet, Close-Coupled Tank:

1. Bowl:
  - a. Material: Vitreous china.
  - b. Type: Siphon jet.
  - c. Style: Flushometer tank, gravity.
  - d. Height: ADA compliant.
  - e. Rim Contour: Elongated.
  - f. Water Consumption: 1.6 gal. per flush.
  - g. Color: White.

## 2.3 FLUSHOMETER VALVES

### A. Flushometer Valves - Diaphragm, Lever Handle:

1. Minimum Pressure Rating: 125 psig.
2. Features: Include integral check stop and backflow-prevention device.
3. Material: Brass body with corrosion-resistant components.
4. Style: Exposed.
5. Flushometer-Valve Finish: Chrome-plated.
6. Handle Finish: Chrome-plated.
7. Consumption: 1.6 gal. per flush.
8. Minimum Inlet: NPS 1.
9. Minimum Outlet: NPS 1-1/4.

## 2.4 TOILET SEATS

### A. Toilet Seats:

1. Material: Plastic.
2. Type: Commercial (Heavy duty).
3. Shape: Elongated rim, open front.
4. Hinge: Check.
5. Hinge Material: Noncorroding metal.
6. Color: White.
7. Surface Treatment: Antimicrobial.

## 2.5 SUPPORTS

### A. Water-Closet Carrier:

1. Description: Waste-fitting assembly, as required to match drainage piping material and arrangement with faceplates, couplings gaskets, and feet; bolts and hardware matching fixture.



## PART 3 - EXECUTION

### 3.1 EXAMINATION

- A. Examine roughing-in for water-supply piping and sanitary drainage and vent piping systems to verify actual locations of piping connections before water-closet installation.
- B. Examine walls and floors for suitable conditions where water closets will be installed.
- C. Proceed with installation only after unsatisfactory conditions have been corrected.

### 3.2 INSTALLATION, GENERAL

#### A. Water-Closet Installation:

- 1. Install level and plumb.
- 2. Install floor-mounted water closets on bowl-to-drain connecting fitting attachments to piping or building substrate.
- 3. Install accessible, wall-mounted water closets at mounting height in accordance with ICC A117.1.

#### B. Support Installation:

- 1. Install supports, affixed to building substrate, for floor-mounted, back-outlet water closets.
- 2. Use carrier supports with waste-fitting assembly and seal.
- 3. Install floor-mounted, back-outlet water closets attached to building floor substrate, onto waste-fitting seals; and attach to support.
- 4. Install wall-mounted, back-outlet water-closet supports with waste-fitting assembly and waste-fitting seals; and affix to building substrate.
- 5. Measure support height installation from finished floor, not structural floor.

#### C. Flushometer-Valve Installation:

- 1. Install flushometer-valve, water-supply fitting on each supply to each water closet.
- 2. Attach supply piping to supports or substrate within pipe spaces behind fixtures.
- 3. Install lever-handle flushometer valves for accessible water closets with handle mounted on open side of water closet.
- 4. Install actuators in locations easily reachable for people with disabilities.

#### D. Install toilet seats on water closets.

#### E. Wall Flange and Escutcheon Installation:

- 1. Install wall flanges or escutcheons at piping wall penetrations in exposed, finished locations and within cabinets and millwork.
- 2. Install deep-pattern escutcheons if required to conceal protruding fittings.
- 3. Comply with escutcheon requirements specified in applicable plumbing codes.

F. Joint Sealing:

1. Seal joints between water closets and walls and floors using sanitary-type, one-part, mildew-resistant silicone sealant.
2. Match sealant color to water-closet color.
3. Comply with sealant requirements.

3.3 PIPING CONNECTIONS

- A. Connect water closets with water supplies and soil, waste, and vent piping. Use size fittings required to match water closets.
- B. Comply with water piping requirements specified in applicable plumbing codes.
- C. Comply with soil and waste piping requirements specified in applicable plumbing codes.
- D. Where installing piping adjacent to water closets, allow space for service and maintenance.

3.4 ADJUSTING

- A. Operate and adjust water closets and controls. Replace damaged and malfunctioning water closets, fittings, and controls.
- B. Adjust water pressure at flushometer valves to produce proper flow.

3.5 CLEANING AND PROTECTION

- A. Clean water closets and fittings with manufacturers' recommended cleaning methods and materials.
- B. Install protective covering for installed water closets and fittings.
- C. Do not allow use of water closets for temporary facilities unless approved in writing by Owner.

END OF SECTION 22 42 13.13

## SECTION 22 42 16.13 - COMMERCIAL LAVATORIES

### PART 1 - GENERAL

#### 1.1 SUMMARY

- A. Section Includes:
  - 1. Vitreous-china, wall-mounted lavatories.
  - 2. Manually operated lavatory faucets.
  - 3. Supply fittings.
  - 4. Waste fittings.
  - 5. Lavatory supports.

#### 1.2 ACTION SUBMITTALS

- A. Product Data: For each type of product.
- B. Sustainable Design Submittals:
- C. Shop Drawings: Include diagrams for power, signal, and control wiring of automatic faucets.

#### 1.3 INFORMATIONAL SUBMITTALS

- A. Coordination Drawings: Counter cutout templates for mounting of counter-mounted lavatories.

#### 1.4 CLOSEOUT SUBMITTALS

- A. Operation and maintenance data.

### PART 2 - PRODUCTS

#### 2.1 VITREOUS-CHINA, WALL-MOUNTED LAVATORIES

- A. Lavatory - Vitreous China, Wall Mounted, with Back:
  - 1. Fixture:
    - a. Standard: ASME A112.19.2/CSA B45.1.
    - b. Type: For wall hanging.
    - c. Nominal Size: Rectangular, 20 by 18 inches.
    - d. Faucet-Hole Punching: One hole.

- e. Faucet-Hole Location: Top.
  - f. Color: White.
  - g. Mounting Material: Chair carrier.
2. Faucet: Single lever.
  3. Lavatory Mounting Height: Standard in accordance with ICC A117.1.

## 2.2 MANUALLY OPERATED LAVATORY FAUCETS

- A. Lavatory faucets intended to convey or dispense water for human consumption are to comply with the U.S. Safe Drinking Water Act (SDWA), with requirements of the Authority Having Jurisdiction (AHJ), and with NSF 61/NSF 372, or be certified in compliance with NSF 61/NSF 372 by an American National Standards Institute (ANSI) accredited third-party certification body, that the weighted average lead content at wetted surfaces is less than or equal to 0.25 percent.
- B. Lavatory Faucets - Manual Type: Single-control mixing.
  1. Standard: ASME A112.18.1/CSA B125.1.
  2. General: Include hot- and cold-water indicators; coordinate faucet inlets with supplies and fixture hole punchings; coordinate outlet with spout and fixture receptor.
  3. Body Material: Commercial, solid-brass, or die-cast housing with brazed copper and brass waterway.
  4. Finish: Polished chrome plate.
  5. Maximum Flow Rate: 0.5 gpm or selected manufacturers specification.
  6. Maximum Flow: 0.25 gal.per metering cycle.
  7. Mounting Type: Deck, exposed.
  8. Valve Handle(s): Single lever.
  9. Spout: Rigid type.
  10. Spout Outlet: Aerator.

## 2.3 SUPPLY FITTINGS

- A. NSF Standard: Comply with NSF 61 and NSF 372 for supply-fitting materials that will be in contact with potable water.
- B. Standard: ASME A112.18.1/CSA B125.1.
- C. Supply Piping: Chrome-plated-brass pipe or chrome-plated copper tube matching water-supply piping size. Include chrome-plated-brass or stainless steel wall flange.
- D. Supply Stops: Chrome-plated-brass, one-quarter-turn, ball-type or compression valve with inlet connection matching supply piping.

## 2.4 WASTE FITTINGS

- A. Standard: ASME A112.18.2/CSA B125.2.

- B. Drain: Grid type with NPS 1-1/4 offset and straight tailpiece.
- C. Trap:
  - 1. Size: As designated by selected manufacturer.
  - 2. Material:
    - a. Stainless steel, two-piece trap and swivel elbow with 0.012-inch-thick stainless steel tube to wall; and stainless steel wall flange.

## 2.5 LAVATORY SUPPORTS

- A. Lavatory Carrier:
  - 1. Standard: ASME A112.6.1M.

## PART 3 - EXECUTION

### 3.1 INSTALLATION

- A. Install lavatories level and plumb in accordance with roughing-in drawings.
- B. Install supports, affixed to building substrate, for wall-mounted lavatories.
- C. Install accessible wall-mounted lavatories at handicapped/elderly mounting height for people with disabilities or the elderly, in accordance with ICC A117.1.
- D. Install wall flanges or escutcheons at piping wall penetrations in exposed, finished locations. Use deep-pattern escutcheons if required to conceal protruding fittings.
- E. Seal joints between lavatories, counters, and walls using sanitary-type, one-part, mildew-resistant silicone sealant. Match sealant color to fixture color.
- F. Install protective shielding pipe covers and enclosures on exposed supplies and waste piping of accessible lavatories.

### 3.2 PIPING CONNECTIONS

- A. Connect fixtures with water supplies, stops, and risers, and with traps, soil, waste, and vent piping. Use size fittings required to match fixtures.

### 3.3 ELECTRICAL CONNECTIONS

- A. Install electrical devices furnished by manufacturer, but not factory mounted in accordance with NFPA 70 and NECA 1.

- B. Install nameplate for each electrical connection, indicating electrical equipment designation and circuit number feeding connection.

#### 3.4 ADJUSTING

- A. Operate and adjust lavatories and controls. Replace damaged and malfunctioning lavatories, fittings, and controls.
- B. Install new batteries in battery-powered, electronic-sensor mechanisms.

#### 3.5 CLEANING AND PROTECTION

- A. After completing installation of lavatories, inspect and repair damaged finishes.
- B. Clean lavatories, faucets, and other fittings with manufacturers' recommended cleaning methods and materials.
- C. Provide protective covering for installed lavatories and fittings.
- D. Do not allow use of lavatories for temporary facilities unless approved in writing by Owner.

END OF SECTION 22 42 16.13

## SECTION 22 42 16.16 - COMMERCIAL SINKS

### PART 1 - GENERAL

#### 1.1 SUMMARY

- A. Section Includes:
  - 1. Service sinks.
  - 2. Manually operated sink faucets.
  - 3. Supply fittings.
  - 4. Waste fittings.
  - 5. Sink supports.
  - 6. Grout.

#### 1.2 ACTION SUBMITTALS

- A. Product Data: For each type of product.

#### 1.3 INFORMATIONAL SUBMITTALS

- A. Coordination Drawings: Counter cutout templates for mounting of counter-mounted sinks.

#### 1.4 CLOSEOUT SUBMITTALS

- A. Operation and maintenance data.

### PART 2 - PRODUCTS

#### 2.1 SERVICE SINKS

- A. Service Sinks - Plastic, Floor Mounted:
  - 1. Fixture:
    - a. Standard: CSA B45.5/IAPMO Z124.
    - b. Material: Molded Polymer
    - c. Nominal Size: 24 by 24 by 10 inches
    - d. Rim Guard: On front top surfaces.
  - 2. Mounting: On floor and flush to wall.
  - 3. Faucet: Insert service sink faucet designation from "Manually Operated Sink Faucets".

## 2.2 MANUALLY OPERATED SINK FAUCETS

- A. Sink faucets intended to convey or dispense water for human consumption are to comply with the U.S. Safe Drinking Water Act (SDWA), with requirements of the Authority Having Jurisdiction (AHJ), and with NSF 61 and NSF 372, or be certified in compliance with NSF 61 and NSF 372 by an ANSI-accredited third-party certification body, in that the weighted average lead content at wetted surfaces is less than or equal to 0.25 percent.
- B. Commercial Sink Faucets - Manual Type: Two-handle mixing.
  - 1. Standard: ASME A112.18.1/CSA B125.1.
  - 2. General: Include hot- and cold-water indicators; coordinate faucet inlets with supplies and fixture hole punchings; coordinate outlet with spout and sink receptor.
  - 3. Body Type: Centerset.
  - 4. Body Material: Commercial, solid brass, or die-cast housing with brazed copper and brass waterway.
  - 5. Finish: Chrome plated.
  - 6. Maximum Flow Rate: 1.5 gpm or as indicated by selected manufacturer.
  - 7. Mounting Type: Back/wall, exposed.
  - 8. Valve Handle(s): Lever.
  - 9. Spout Type: Swing.
  - 10. Spout Outlet: Laminar flow.

## 2.3 SUPPLY FITTINGS

- A. NSF Standard: Comply with NSF 61 and NSF 372 for supply-fitting materials that will be in contact with potable water.
- B. Standard: ASME A112.18.1/CSA B125.1.
- C. Supply Piping: Chrome-plated brass pipe or chrome-plated copper tube matching water-supply piping size. Include chrome-plated brass or stainless steel wall flange.
- D. Supply Stops: Chrome-plated brass, one-quarter-turn, ball-type or compression valve with inlet connection matching supply piping.

## 2.4 WASTE FITTINGS

- A. Standard: ASME A112.18.2/CSA B125.2.
- B. Drain: Grid type with NPS 1-1/2 offset and straight tailpiece.
- C. Trap:
  - 1. Size: NPS 1-1/2.
  - 2. Material:



- a. Chrome-plated, as required by selected sink manufacturer and chrome-plated brass or steel wall flange.

## 2.5 SINK SUPPORTS

### A. Sink Carrier:

1. Standard: ASME A112.6.1M.

## 2.6 GROUT

- A. Standard: ASTM C1107/C1107M, Grade B, post-hardening and volume-adjusting, dry, hydraulic-cement grout.
- B. Characteristics: Nonshrink; recommended for interior and exterior applications.
- C. Design Mix: 5000 psi, 28-day compressive strength.
- D. Packaging: Premixed and factory packaged.

## PART 3 - EXECUTION

### 3.1 INSTALLATION

- A. Install sinks level and plumb in accordance with rough-in drawings.
- B. Install supports, affixed to building substrate, for wall-hung sinks.
- C. Set floor-mounted sinks in leveling bed of cement grout.
- D. Install water-supply piping with stop on each supply to each sink faucet.
  1. Install stops in locations where they can be easily reached for operation.
- E. Install wall flanges or escutcheons at piping wall penetrations in exposed, finished locations. Use deep-pattern escutcheons if required to conceal protruding fittings. Comply with escutcheon requirements specified in applicable plumbing codes.
- F. Seal joints between sinks and counters, floors, and walls using sanitary-type, one-part, mildew-resistant silicone sealant. Match sealant color to fixture color.
- G. Install protective shielding pipe covers and enclosures on exposed supplies and waste piping of accessible sinks to comply with applicable plumbing codes.

### 3.2 PIPING CONNECTIONS

- A. Connect fixtures with water supplies, stops, and risers, and with traps, soil, waste, and vent piping. Use size fittings required to match fixtures.
- B. Comply with water piping requirements specified in applicable plumbing codes.
- C. Comply with soil and waste piping requirements specified in applicable plumbing codes.

### 3.3 ELECTRICAL CONNECTIONS

- A. Connect wiring in accordance with applicable electrical codes.
- B. Ground equipment in accordance with applicable electrical codes.
- C. Install electrical devices furnished by manufacturer, but not factory mounted in accordance with NFPA 70 and NECA 1.
- D. Install nameplate for each electrical connection, indicating electrical equipment designation and circuit number feeding connection.

### 3.4 ADJUSTING

- A. Operate and adjust sinks and controls. Replace damaged and malfunctioning sinks, fittings, and controls.
- B. Install new batteries in battery-powered, electronic-sensor mechanisms.

### 3.5 CLEANING AND PROTECTION

- A. After completing installation of sinks, inspect and repair damaged finishes.
- B. Clean sinks, faucets, and other fittings with manufacturers' recommended cleaning methods and materials.
- C. Provide protective covering for installed sinks and fittings.
- D. Do not allow use of sinks for temporary facilities unless approved in writing by Owner.

END OF SECTION 22 42 16.16

## SECTION 22 47 13 - DRINKING FOUNTAINS

### PART 1 - GENERAL

#### 1.1 SUMMARY

- A. Section Includes:
  - 1. Drinking fountains.
  - 2. Supports.

#### 1.2 ACTION SUBMITTALS

- A. Product Data: For each type of drinking fountain and bottle filling station.
- B. Shop Drawings:
  - 1. Include diagrams for power wiring.

#### 1.3 CLOSEOUT SUBMITTALS

- A. Maintenance data.

### PART 2 - PRODUCTS

#### 2.1 PERFORMANCE REQUIREMENTS

- A. Standards:
  - 1. Drinking fountains and bottle filling stations intended to convey or dispense water for human consumption are to comply with the U.S. Safe Drinking Water Act (SDWA), requirements of the Authority Having Jurisdiction (AHJ), and with NSF 61 or NSF 372, or be certified in compliance with NSF 61 or NSF 372 by an ANSI-accredited third-party certification body, that the weighted average lead content at wetted surfaces is less than or equal to 0.25 percent.
  - 2. Comply with ASME A112.19.3/CSA B45.4 for stainless steel drinking fountains.
  - 3. Comply with NSF 42 and NSF 53 for water filters for drinking fountains and bottle filling stations.
  - 4. Comply with ICC A117.1 for accessible drinking fountains and bottle filling stations.

#### 2.2 DRINKING FOUNTAINS

- A. Drinking Fountains - Surface Wall-Mounted, Stainless Steel:

1. Type: High-Low drinking fountain.
2. Receptor(s):
  - a. Shape: Rectangular.
  - b. Back Panel: Stainless steel wall plate behind drinking fountain.
  - c. Bubblers: One for each receptor, with adjustable stream regulator, located on deck.
  - d. Drain: Grid type with NPS 1-1/4 tailpiece.
3. Maximum Water Flow: 0.15 gpm.
4. Control: Push bar.
5. Supply: NPS 3/8 with shutoff valve.
6. Waste Fitting: ASME A112.18.2/CSA B125.2, NPS 1-1/4 chrome-plated brass P-trap and waste.
7. Filter: One or more water filters with capacity sized for unit peak flow rate.
8. Electrical Characteristics:
  - a. Volts: 120 V ac.
  - b. Phase: Single.
  - c. Hertz: 60 Hz.
9. Support: Provide manufacturer's mounting plate and drinking fountain carrier.
10. Drinking Fountain Mounting Height: High/low - standard/accessible in accordance with ICC A117.1.

## 2.3 SUPPORTS

- A. Drinking Fountain Carrier:
  1. Standard: ASME A112.6.1M.

## PART 3 - EXECUTION

### 3.1 INSTALLATION

- A. Install fixtures level and plumb according to roughing-in drawings. For fixtures indicated for children, install at height required by authorities having jurisdiction.
- B. Set pedestal drinking fountains and bottle filling stations on flat surface in accordance with manufacturer's written installation instructions.
- C. Install recessed, drinking fountains and bottle filling stations secured to wood blocking in wall construction.
- D. Install off-the-floor carrier supports, affixed to building substrate, for wall-mounted fixtures.

- E. Install water-supply piping with shutoff valve on supply to each fixture to be connected to domestic-water distribution piping. Use ball or gate valve. Install valves in locations where they can be easily reached for operation.
- F. Install trap and waste piping on drain outlet of each fixture to be connected to sanitary drainage system.
- G. Install wall flanges or escutcheons at piping wall penetrations in exposed, finished locations. Use deep-pattern escutcheons where required to conceal protruding fittings.
- H. Seal joints between fixtures and walls using sanitary-type, one-part, mildew-resistant, silicone sealant. Match sealant color to fixture color.

### 3.2 PIPING CONNECTIONS

- A. Connect fixtures with water supplies, stops, and risers, and with traps, soil, waste, and vent piping. Use size fittings required to match fixtures.
- B. Comply with water piping requirements specified in applicable plumbing codes.
- C. Install ball or gate shutoff valve on water supply to each fixture. Comply with valve requirements specified in applicable plumbing codes.
- D. Comply with soil and waste piping requirements specified in applicable plumbing codes.

### 3.3 ELECTRICAL CONNECTIONS

- A. Ground equipment according to applicable electrical codes.
- B. Install electrical devices furnished by manufacturer, but not factory mounted, according to NFPA 70 and NECA 1.
- C. Install nameplate for each electrical connection, indicating electrical equipment designation and circuit number feeding connection.

### 3.4 ADJUSTING

- A. Adjust fixture flow regulators for proper flow and stream height.

### 3.5 CLEANING

- A. After installing fixtures, inspect unit. Remove paint splatters and other spots, dirt, and debris. Repair damaged finish to match original finish.
- B. Clean fixtures, on completion of installation, according to manufacturer's written instructions.

- C. Provide protective covering for installed fixtures.
- D. Do not allow use of fixtures for temporary facilities unless approved in writing by Owner.

END OF SECTION 22 47 13

## SECTION 31 05 00 – SOILS, AGGREGATES AND GEOTEXTILES FOR EARTHWORK

### PART 1 - GENERAL

#### 1.1 SUMMARY

A. Section Includes:

1. Subsoil materials.
2. Topsoil materials.
3. Coarse aggregate materials.
4. Fine aggregate materials.
5. Turf reinforcement mats (TRMs).
6. Non-woven geotextile materials.

#### 1.2 REFERENCES

- A. American Association of State Highway and Transportation Officials
- B. ASTM International

#### 1.3 SUBMITTALS

- A. Section 01 33 00 – Submittals: Requirements for Submittals.
- B. Product Data: Submit manufacturer information including tensile strength, elongation, thickness, UV resistance, and other material specifications.
- C. Shop Drawings: Indicate fabric layout, seam locations, and overlap details in installation drawings.
- D. Samples:
  1. Submit a sample, full width by 24 inches long, for each type and weight of geotextile used on Project, illustrating thickness and seaming method.
  2. Submit a sample, 24 inches by 6 feet long, for each type and weight of geotextile used on Project, illustrating field seaming method.
- E. Manufacturer's Certificate: Certify that products meet or exceed specified requirements.
- F. Manufacturer Instructions: Submit detailed instructions on installation requirements, including storage and handling procedures.
- G. Source Quality-Control Submittals: Indicate results of shop tests and inspections.
- H. Field Quality-Control Submittals: Indicate results of Contractor-furnished tests and inspections.

- I. Qualifications Statements:
  - 1. Submit qualifications for manufacturer and installer.
  - 2. Submit manufacturer's approval of installer.

#### 1.4 QUALITY ASSURANCE

- A. Furnish each fill material and each topsoil material from single source throughout the Work.

#### 1.5 QUALIFICATIONS

- A. Manufacturer: Company specializing in manufacturing products specified in this Section with minimum three years' experience.
- B. Installer: Company specializing in performing Work of this Section with minimum three years' experience.

#### 1.6 DELIVERY, STORAGE, AND HANDLING

- A. Section 01 60 00 - Product Requirements: Requirements for transporting, handling, storing, and protecting products.
- B. Inspection: Accept materials on Site in manufacturer's original packaging and inspect for damage.
- C. Comply with ASTM D4873.
- D. Store materials according to manufacturer instructions.
- E. Protection:
  - 1. Protect materials from moisture and dust by storing in clean, dry location remote from construction operations areas.
  - 2. Provide additional protection according to manufacturer instructions.

### PART 2 - PRODUCTS

#### 2.1 SUBSOIL MATERIALS

- A. Excavated and reused subsoil:
  - 1. Graded.
  - 2. Free of lumps larger than 6 inches, rocks larger than 3 inches, and debris. Materials used for embankments shall not contain logs, stumps, brush, perishable materials, frozen lumps of soil, rocks, or pieces of pavement of such size or conformation that they would interfere with proper compaction.



## 2.2 TOPSOIL MATERIALS

- A. Excavated and reused topsoil:
1. Excavated and reused material.
  2. Graded.
  3. Free of roots, rocks larger than ½-inch, subsoil, debris, large weeds and foreign matter.
- B. Imported topsoil:
1. Friable loam.
  2. Completely free of roots, rocks larger than ½-inch, subsoil, debris, large weeds, foreign matter, atrazine, and any other similar chemicals harmful to plant growth.
  3. Reasonably free of weed seed.
  4. Single screened.
  5. Acidity range (pH) of 5.5 to 7.5.
  6. Containing minimum of 4% and maximum of 25% inorganic matter.

## 2.3 COARSE AGGREGATE MATERIALS

- A. Coarse Aggregate Type A1 (Breaker Run): AASHTO M147, 90% passing 3-inch sieve with liquid limit of not more than 25, plasticity index of not more than five in accordance with ASTM D4318.
- B. Coarse Aggregate Type A2 (Crushed Stone): Free of shale, clay, friable material and debris, graded in accordance with ASTM C136, within the following limits, based on ASTM D448:
1. Percent Passing per Sieve Size:
    - a. 2-Inch: 100
    - b. 1½-Inch: 95
    - c. ¾-Inch: 70 - 93
    - d. ⅜-Inch: 42 - 80
    - e. No. 4: 25 - 63
    - f. No. 10: 16 - 48
    - g. No. 40: 8 - 28
    - h. No. 200: 2 - 12
- C. Aggregate Type A3 (Pea Gravel): Natural stone, free of clay, shale, organic matter, graded in accordance with ASTM C136, to the following limits:
1. Minimum Size: ¼-inch
  2. Maximum Size: ⅝-inch

2.4 FINE AGGREGATE MATERIALS

- A. Fine Aggregate Type A4 (Sand): Natural river or bank sand, free of silt, clay, loam, friable or soluble materials, and organic matter, graded in accordance with ASTM C136, within the following limits:

1. Percent Passing per Sieve Size:

- a. No. 4: 100
- b. No. 16 10 to 100
- c. No. 50 5 to 90
- d. No. 100 4 to 30
- e. No. 200 0

2.5 GEOTEXTILES, GENERAL

- A. Furnish geotextiles of either woven or nonwoven polyester, polypropylene, stabilized nylon, polyethylene, or polyvinylidene chloride. Fabric shall have the minimum strength values in the weakest primary direction. The Contractor may use nonwoven fabric that is one or a combination of the following: needle punched, heat bonded, or resin bonded.
- B. If using sewn seams, furnish a field sewn seam sample produced from the geotextile and thread and with the equipment proposing to use on the project, before incorporating into the work.
- C. Furnish material that is insect, rodent, mildew, and rot resistant in a wrapping that protects it from ultraviolet radiation and from abrasion due to shipping and hauling. Keep material dry until installed. Clearly mark rolls to show the material type.

2.6 GEOTEXTILES FOR SUBGRADE – AGGREGATE SEPARATION

- A. Furnish fabric conforming to the following physical properties:

Test	Method	Value <sup>[1]</sup>
Minimum grab tensile strength	ASTM D4632	170 lb.
Minimum puncture strength	ASTM D4833	70 lb.
Maximum apparent opening size	ASTM D4751	No. 70
Minimum permittivity	ASTM D4491	0.35 s <sup>-1</sup>

[1] All numerical values represent minimum/maximum average roll values. Average test results from all rolls in a lot must conform to the tabulated values.

2.7

2.8 GEOTEXTILES FOR SUBGRADE REINFORCEMENT

- A. Provide geogrid for subgrade reinforcement that complies with the following physical properties:

Test	Method	Value <sup>[1]</sup>
Tensile Strength at 5% Strain (both principal directions in lb/ft)	ASTM D4595 <sup>[2]</sup>	450 min.
Flexural Rigidity (both principal directions in mg/cm)	ASTM D1388 <sup>[3]</sup>	150,000 min.
Aperture Area (in <sup>2</sup> )	Inside Measurement <sup>[4]</sup>	5.0 max.
Aperture Dimension (in)	Inside Measurement <sup>[4]</sup>	0.5 min.

PART 3 - [1] All numerical values represent minimum/maximum average roll values. Average test results from all rolls in a lot must conform to the tabulated values. [2] The tensile strength (T) of a joined multi-layered geogrid shall be computed using the following equation:

PART 4 -  $T = n \times t \times f$

PART 5 - Where:

PART 6 - n = the number of individual layers in the joined multi-layered geogrid

PART 7 - t = the tensile strength of a single layer of geogrid as determined using testing method ASTM D4595

PART 8 - f = reduction factor based on the number of layers comprising the multilayered system and determined by the equation  $f = 1.00 - [0.04(n - 1)]$

PART 9 - [3] Values determined by option "A" cantilever test of testing method ASTM D1388 using test specimens that are 36 inches  $\pm 0.04$  inch long. Test specimen widths for differing geogrids are variable and equal to one element plus 1/2 the aperture width on both sides of that element. An element is defined as the minimum number of parallel strands that form a distinguishable repeating pattern.

PART 10 - [4] Aperture area and aperture dimension for joined multi-layer geogrids are determined based on measurement of a single layer of the geogrid.

## 10.1 GEOTEXTILES FOR LIGHT DUTY SOIL SURFACE STABILIZATION

- A. Furnish geotextiles from the Wisconsin Department of Transportation-approved products list for geotextiles, Class I, Type B.

## 10.2 GEOTEXTILES FOR HEAVY DUTY, STEEP SLOPE (2:1 OR FLATTER) SOIL SURFACE STABILIZATION

- A. Furnish geotextiles from the Wisconsin Department of Transportation-approved products list for geotextiles, Class II, Type B.

10.3 TURF REINFORCEMENT MAT (TRM) (SLOPES 1:1 OR FLATTER)

- A. Furnish geotextiles from the Wisconsin Department of Transportation-approved products list for geotextiles, Class III, Type D.

10.4 SOURCE QUALITY CONTROL

- A. Section 01 40 00 - Quality Requirements: Requirements for testing, inspection, and analysis.
- B. Certificate of Compliance for Geotextiles:
  - 1. Submit certificate of compliance indicating Work performed at manufacturer's facility conforms to Contract Documents.
  - 2. Shop tests are not required for Work performed by approved manufacturer.
- C. Coarse Aggregate Material - Testing and Analysis: Perform according to ASTM D1557, AASHTO T180, ASTM D4318, and ASTM C136.
- D. Fine Aggregate Material -Testing and Analysis: Perform according to ASTM D1557, AASHTO T180, ASTM D4318, and ASTM C136.
- E. When tests indicate materials do not meet specified requirements, change material and retest.

PART 11 - EXECUTION

11.1 COMPACTION

- A. Compact all soils and aggregates within 3 feet of the finished surface to 95% Modified Proctor Density (ASTM D1557).
- B. Compact all soils and aggregates greater than 3 feet below the finished surface to 90% Modified Proctor Density (ASTM D1557).

11.2 STOCKPILING

- A. Stockpile materials on-site.
- B. Stockpile in sufficient quantities to meet Project schedule and requirements.
- C. Separate differing materials with dividers or stockpile individually to prevent mixing.
- D. Stockpile topsoil 8 feet high maximum.
- E. Prevent intermixing of soil types or contamination.

- F. Direct surface water away from stockpile site to prevent erosion or deterioration of materials.

### 11.3 STOCKPILE CLEANUP

- A. Remove stockpile, leave area in clean and neat condition. Grade site surface to prevent free standing surface water.

### 11.4 INSTALLATION OF GEOTEXTILES

- A. Verify that underlying surface is smooth and free of ruts or protrusions that could damage geotextile material.

- B. Geotextile Material:

1. Lay and maintain smooth and free of tensile stresses, folds, wrinkles, or creases.
2. Ensure that material is in direct contact with subgrade.
3. Orientate with long dimension of each sheet parallel to direction of slope.
4. Minimum Unseamed Joints Overlap: 18 inches.

- C. Securement Pins:

1. Insert through geotextile midway between edges of overlaps and minimum 6 inches from free edges.
2. Minimum Spacing:
  - a. Slopes Steeper than 3 Horizontal on 1 Vertical: 24 inches o.c.
  - b. Slopes 3 Horizontal on 1 Vertical to 4 Horizontal on 1 Vertical: 3 feet o.c.
  - c. Slopes Flatter than 4 Horizontal on 1 Vertical: 5 feet o.c.
3. Ensure that washer bears against geotextile.

- D. Seams:

1. Minimum Seamed Joints Overlap: 12 inches at longitudinal and transverse joints.
2. Seams across Slope: Lap upper panel over lower panel.
3. Sewn Seams:
  - a. Continuously sew seams on slopes steeper than 1 vertical on 2 horizontal.
  - b. Stitch Type: As recommended by geotextile manufacturer.
  - c. Tie off thread at the end of each seam to prevent unraveling.
4. Thermal Seams:
  - a. As recommended by geotextile manufacturer.
  - b. Comply with ASTM D4886.

- E. Penetrations: As recommended by geotextile manufacturer.

- F. Repairing Damaged Geotextiles:

1. Repair torn or damaged geotextile by placing patch of same type of geotextile over damaged area minimum of 12 inches beyond edge of damaged area, and fasten as recommended by geotextile manufacturer.
2. Remove and replace geotextile rolls which cannot be repaired.

G. Fill and Cover:

1. Place fill to prevent tensile stress or wrinkles in geotextile.
2. Place fill from bottom of side-slopes upward.
3. Do not drop fill from height greater than 3 feet.

11.5 PROTECTION

- A. Ballast: Adequate to prevent uplift of material by wind.
- B. UV Exposure: Do not leave material uncovered for more than 14 days after installation.
- C. Do not use staples or pins to hold geotextiles in place where located adjacent to other geosynthetic layers that could be damaged.
- D. Do not operate equipment directly on top of geotextile.

11.6 END OF SECTION 31 05 00

Edit the following paragraphs for submitting soil samples for testing and analysis.

## SECTION 31 22 13 – ROADWAY EXCAVATION & GRADING

### PART 1 - GENERAL

#### 1.1 SUMMARY

##### A. Contractor Responsibilities

1. The Contractor shall complete excavation, backfill, embankment, compaction and grading as necessary to prepare the roadway or street for application of base course and pavement as shown on the cross-sections and details of the Plans. The Contractor shall legally dispose of all excess or unsuitable materials. The Contractor shall blend private lawns, driveways, alleys and intersecting streets.

##### B. Section Includes:

1. Excavating topsoil.
2. Excavating subsoil.
3. Excavating for roads, street and parking areas.
4. Excavating for landscaping.
5. Fill under slabs-on-grade.
6. Fill under paving.
7. Compaction of Fill
8. Grading and compacting site for slabs-on-grade, paving and landscaping.

## 1.2 REFERENCES

- A. American Association of State Highway and Transportation Officials
- B. ASTM International
- C. Local utility standards when working in the vicinity of utility lines.

## 1.3 SUBMITTALS

- A. Section 01 33 00 - Submittals: Requirements for submittals.
- B. Product data: Submit data for any geotextile fabric used.
- C. Materials source: Submit name of imported materials suppliers.

## PART 2 - PRODUCTS

### 2.1 MATERIALS

- A. Topsoil: As specified in Section 32 05 00.
- B. Embankment materials: Materials used for embankment shall not contain logs, stumps, brush, perishable materials, frozen lumps of soil, or rocks or pieces of pavement of such size or conformation that they would interfere with proper compaction. Materials to be incorporated in the top 18 inches of earth embankments shall be free of stones, or pieces of pavement, which are greater than six (6) inches in any dimension.
- C. Crushed aggregate: As specified in Section 32 05 00.

## PART 3 - EXECUTION

### 3.1 EXAMINATION

- A. Verify existing conditions before starting work.



- B. Verify survey bench mark and intended elevations for the Work are as indicated on Drawings.

### 3.2 PREPARATION

- A. Call Local Utility Line Information service not less than three working days before performing Work.
  - 1. Request underground utilities to be located and marked within and surrounding construction areas.
- B. Identify required lines, levels, contours, and datum.
- C. Notify utility companies to remove or relocate conflicting utilities.
- D. Protect utilities to remain from damage.
- E. Protect plant life, lawns, and other features remaining as portion of final landscaping.
- F. Protect bench marks, sidewalks, paving, and curbs from excavating equipment and vehicular traffic.

### 3.3 CLEARING & GRUBBING

- A. Contractor shall remove and legally dispose of existing trees, shrubs, fences pavements and other obstacles within the construction area where removal of such obstacles is necessary to complete the work and as shown on the plans. Remove only those trees and shrubs marked for removal on the plans.
- B. The Contractor shall protect remaining trees and shrubs from scarring or from injury of any type. The excavation operations shall not disturb the original ground surface within one foot of trees or shrubs or within twice the diameter of trees, whichever is greater. Roots which may be exposed as a result of excavation shall be cut cleanly and covered with soil with high humus content. When necessary, or when required by the Plans or the Special Conditions, tree wells shall be constructed to protect trees and shrubs from embankments. In such cases, tree well design shall be as shown on the Plans or as approved by the Engineer.

### 3.4 TOPSOIL EXCAVATION

- A. Excavate topsoil from areas to be further excavated, re-landscaped or regraded, without mixing with foreign materials for use in finish grading.
- B. Do not excavate wet topsoil.

- C. Stockpile on site to depth not exceeding 8 feet and protect from erosion.
- D. Excess topsoil not needed for reuse shall be stockpiled as directed by the Owner.

### 3.5 SUBSOIL EXCAVATION

#### A. Definitions

1. Common excavation shall be defined as the excavation of all materials that can be excavated, transported, and unloaded by the use of heavy ripping equipment and wheel tractor scrapers with pusher tractors or that can be excavated and dumped into place or loaded onto hauling equipment by means of excavators having a rated capacity of one (1) cubic yard equipped with attachments (such as shovel, bucket, backhoe, dragline, or clam shell) appropriate to the character of the materials and the site conditions. For the purposes of this classification heavy ripping equipment shall be defined as a rear-mounted, heavy duty, single tooth, ripping attachment mounted on a tractor having a power rating of 200-300 net horsepower, at the flywheel, such equipment being in well-maintained condition. Pusher tractor shall be defined as a track-type tractor having a power rating of 200-300 net horsepower, at the flywheel, equipped with appropriate attachments and being in well-maintained operating condition.
2. Rock excavation shall be defined as the excavation of all hard, compacted or cemented materials, the excavation of which requires blasting or use of excavators larger than defined for common excavation. Such rock excavation shall include all hard, solid rock ledges, bedded deposits or any other material as firmly-cemented as to present all the characteristics of solid rock. The excavation and removal of isolated boulders or rock fragments larger than one (1) cubic yard in volume encountered in materials otherwise conforming to the definition of common excavation shall be classified as rock excavation. Rock excavation will merit extra payment unless a separate bid item has been provided or unless elsewhere in the specifications such rock excavation is declared incidental to the work. Existing asphaltic or concrete pavements, curb & gutter, sidewalk and utility structures shall be classified as common excavation. The presence of isolated boulders or rock fragments larger than one (1) cubic yard in size will not, in itself, be sufficient cause to change the classification of surrounding material.

- B. The Contractor shall excavate as shown on the Plans and legally dispose of all excess materials to allow construction of the roadway. Earthwork shall include, but not be limited to, excavation within the roadway; embankments with the roadway; excavation and embankments to create intersections, ditches, channels, waterways and dikes; grading of the roadway subgrade, entrances and approaches; and other such activities outside the right-of-way as may be specifically designated on the Plans. Earthwork shall include the removal and reuse or satisfactory disposal of existing pavements and base courses, masonry or concrete structures, and other structures that may be within the right-of-way.
- C. Monuments from land surveys which are shown on the plans or which are clearly visible in the field and which are in the path of the work shall be carefully protected from movement. If the Contractor feels that removal is necessary he shall notify the Engineer at least 48 hours in advance of such removal. If the Engineer concurs that removal is necessary, the municipality will assume the cost of resetting those monuments, unless

a bid price is provided in the Bid Proposal or unless elsewhere in the specifications it is stated that removal and replacement of monuments is incidental to the bid price(s). Monuments that the Contractor moves due to failure to exercise reasonable precautions or proper construction techniques, or for which he has failed to notify the Engineer sufficiently in advance, shall be replaced at the Contractor's cost.

- D. The Contractor shall notify utility companies of any interfering structures or cables and shall arrange for those structures or cables to be moved, if necessary. The project plans show the approximate location and size of sewers, drains, culverts, gas mains, water mains, electric, and telephone conduits and other underground structures or utilities, as such locations and sizes are available to the municipality, or as surface markings indicate their existence. The Contractor shall arrange with the utility companies for exact location of utilities and for necessary relocations or modifications of interfering utilities. The cost of arranging such relocations or modifications, and the cost of any "downtime" resulting from delays or changes to the Contractor's work schedule as a result of waiting for a private utility (gas, electric, telephone, cable TV) to make the relocation or modifications shall be incidental to the Contractor's bid. The Contractor shall use caution in excavating and trenching so that the exact location of underground structures, both known and unknown, may be determined; the Contractor shall be held responsible for the repair of such structures when broken or otherwise damaged during construction. When the Owner permits the Contractor to make a change in the project to avoid utility relocation, the Engineer shall determine whether the change constitutes extra work as defined in the General Conditions. Such relocations shall not be cause for extension of contract time of completion.
- E. The Contractor shall also, at least one week in advance of his operations, notify private property owners who have structures or who have planted trees, shrubbery, or flowers in the right-of-way so that the private property owners may remove and reinstall such features if they so wish. The Contractor shall be responsible for removal, temporary relocation, and replacement of all mail and newspaper delivery boxes. The Contractor shall contact the local postmaster to determine acceptable locations and heights of such boxes. Replacement of such boxes shall be in locations acceptable to the property owner.
- F. Deposits of frost heave material, unstable soils such as clay or muck, soil containing considerable amounts of organic matter, or other undesirable foundation material shall be excavated as directed by the Engineer. The Contractor shall notify the Engineer of such questionable materials and obtain the Engineer's approval prior to excavating them. Failure to notify the Engineer of such questionable materials shall be cause for the forfeiture of right to extra payment.
- G. The Contractor shall scarify the subgrade to such depth as necessary to accomplish grading and shaping operations as specified in Subsection 3.5 of this section.
- H. The Contractor shall conduct earthwork operations in such a manner as to avoid removing or disturbing any material or structure outside of the designated construction limits, as shown on the Plans or as defined in the Special Conditions. Should any such material or structure be removed or disturbed the Contractor shall assume the expense of restoring it to its original condition.

### 3.6 FILLING

- A. Compact subgrade to density requirements for subsequent backfill materials.
- B. Cut out soft areas of subgrade not capable of compaction in place.
- C. Fill areas to contours and elevations with unfrozen materials.
- D. The Contractor shall, if possible and feasible, utilize all suitable excavated material for backfill and embankment within the roadway in conformity with the lines, grades, cross-sections and dimensions shown on the Plans or in these Specifications or at other places shown on the Plans. When excavated materials are insufficient or unsuitable the Contractor shall furnish materials from borrow pits approved by the Engineer. Before use of borrow materials, the Contractor shall notify the Engineer so that the materials may be inspected.
- E. Backfill or embankments shall be made in successive uniform layers not exceeding 12 inches in depth. Each layer shall cover the entire area and shall be compacted before additional layers are placed. Prior to compaction each layer shall be worked to break up clods over six (6) inches in any dimension and to obtain uniform moisture content. In the case of filling on steep slopes construct the fill in such layers as can be achieved by the equipment until the fill can be constructed in 12 inch layers. Each layer shall be compacted to 95 percent of maximum density as measured by AASHTO Designation: T99, Method C, with replacement of the fraction of material retained on the  $\frac{3}{4}$ -inch sieve with No. 4 to  $\frac{3}{4}$ -inch material.
- F. Maintain optimum moisture content of fill materials to attain required compaction density.

### 3.7 GRADING AND SHAPING

- A. The Contractor shall shape the subgrade for the full width of the roadbed in advance of base or surface laying operations. The grade of the completed course shall at all points be within + or - 0.04 foot of the grade shown on the Plans, as measured at the curb line or the edge of the pavement, but without more than 5 percent net over-excavation or under-excavation of the subgrade materials for the project. Subgrade need not be crowned between measurement points at opposite edges of the roadway. He shall maintain the subgrade in a firm smooth condition, removing any ruts or surface irregularities produced by hauling equipment or other traffic until final acceptance or until laying of the subbase or base course. The subgrade shall have a compaction of 95 percent of maximum density as measured by AASHTO Designation: T99, Method C, with replacement of the fraction of material retained on the  $\frac{3}{4}$  inch sieve with No. 4 to  $\frac{3}{4}$  inch material. Any soft or yielding places, holes or other defects which may develop in the subgrade by reason of traffic, hauling, poor drainage, unstable materials, or from any other cause shall be corrected before acceptance or before the base or surface course is placed thereon.
- B. Unless otherwise approved by the Engineer, the subbase shall be compacted before any crushed aggregate is added in order to minimize crushed aggregate being forced down into the subbase.

- C. All intersecting road, approaches, entrances and driveways shall be graded as shown on the Plans or as designated in the field by the Owner's Authorized Representative.
- D. Make grade changes gradual. Blend slope into level areas.
- E. During construction, the Contractor shall assure that all ditches and channels are drained at all times by keeping the excavation areas and embankments sloped to the approximate section of the final earth grade. If existing surface drainage must be interrupted alternate drainage shall be provided.
- F. Construction in and adjacent to flowing streams shall be performed to avoid washing, sloughing or deposition of materials into the channel which may obstruct or impair stream flow or which may result in contamination and/or silting of the waterway. The Contractor shall comply with any requirements or permits from the Owner or obtained by the Owner from the Department of Natural Resources and shall use erosion control measures in the locations shown on the Plans or as specified elsewhere in the specifications.
- G. The Contractor shall take precautions to preserve, protect, and continue service of all existing tile drains, sewers and other subsurface utilities and shall repair any damage to drains, sewers, other utilities or surface features.

### 3.8 TOLERANCES

- A. Top Surface of Subgrade: Plus or minus 1 inch from required elevation.

### 3.9 FIELD QUALITY CONTROL

- A. Perform laboratory material tests in accordance with AASHTO T 99.
- B. Perform in place compaction tests in accordance with the following:
  - 1. Density Tests: ASTM D2922.
  - 2. Moisture Tests: ASTM D3017.
- C. A test-roll of the graded and compacted subbase will be required. This test-roll shall be performed with a fully loaded tri-axle dump truck (60,000 pound minimum total weight) with the tag-wheels lifted, provided by the Contractor. The test-roll shall be performed on the entire length and width of the subbase in the presence of an Engineer. Any deflection of the sub-base, wheel rutting, or cracking of the subbase will signify a failure of the subbase. The Engineer shall make the determination of subbase course acceptance or failure. In the case of subbase failure, the Engineer shall determine the area and depth of undercut or other corrective action.

- D. When tests indicate Work does not meet specified requirements, remove Work, replace and retest.

END OF SECTION 31 22 13

## SECTION 31 25 00 - EROSION AND SEDIMENT CONTROL

### PART 1 - GENERAL

#### 1.1 SUMMARY

- A. Description of work covered by this Section
- B. This section describes the requirements for control of erosion on construction sites. The Contractor shall provide the necessary materials, equipment, and labor to control erosion by the methods specified herein. If no specific quantities are shown on the Plans, the Contractor shall use whatever quantities are necessary to prevent sediment transport into adjacent storm water conveyances or streams. Other similar products may be used only with the prior approval of the Engineer. All work under this section shall be done in conformance with the requirements of NR 151 of the Wisconsin Administrative Code and Wisconsin Department of Natural Resources best management practices (BMPs).
- C. Section Includes:
  - 1. Temporary Grass Seed
  - 2. Straw Mulch
  - 3. Filter Fabric
  - 4. Sediment Control (Silt) Fence
  - 5. Double Sediment Control Barrier
  - 6. Construction Entrance Material
  - 7. Straw or Straw/Coconut Fiber Erosion Control Mat
  - 8. Coconut Fiber Erosion Control Mat
  - 9. Erosion Control Polymer (Soil Stabilizer)

10. Temporary Ditch Checks (Wattles)
11. Diversion Channels
12. Rock Energy Dissipator
13. Sediment Traps
14. Dust Control

## 1.2 REFERENCES

- A. American Association of State Highway and Transportation Officials
- B. ASTM International
- C. Wisconsin Department of Natural Resources –(WDNR) Wisconsin Administrative Code NR-151
- D. Wisconsin Department of Transportation (WisDOT Standards) Standard Specifications for Highway and Structure Construction available on the WisDOT website.

## 1.3 SUBMITTALS

- A. Refer to Section 01 33 00 – Submittals
- B. Manufacturer's Certificate: Certify products meet or exceed specified requirements.

## 1.4 CLOSEOUT SUBMITTALS

- A. Section 01 70 00 – Execution Requirements and Project Closeout: Requirements for submittals.

## 1.5 QUALITY ASSURANCE

- A. Perform Work according to these Specifications and all applicable Local, State and Federal regulations

## 1.6 ENVIRONMENTAL REQUIREMENTS

- A. Perform work in accordance the requirements of WDNR NR 151.



## PART 2 - PRODUCTS

### 2.1 MATERIALS, EQUIPMENT AND PRACTICES

#### A. Erosion Control Materials

1. Temporary Grass Seed: Temporary grass seed shall be annual ryegrass, annual oats or winter wheat, depending upon the time of year as set forth in Part 3. Grass seed shall be delivered to the site in bags, tagged, or labeled to show the percentage of purity and germination. The seed shall have been tested by a recognized seed-testing laboratory within one (1) year before the date of seeding and shall conform to the latest laws of the U.S. and the State of Wisconsin. Upon request, the Contractor shall furnish to the Engineer copies of the test results.
2. Straw Mulch: Unless otherwise specified, mulch shall be straw, reasonably free of grain, weed, seed, and mold. Mulch materials shall not contain excessive moisture that might prevent feeding through a mulch blower machine. Other fibers may be used only upon approval by the Engineer.
3. Filter Fabric: Filter fabric for inlet bags shall meet the requirements of the Wisconsin Department of Transportation Product Acceptability List for Inlet Protection, Type D, or equal, and shall be ultraviolet stabilized.
4. Sediment Control (Silt) Fence: Sediment control fabric shall be woven or non-woven polyester, polypropylene, stabilized nylon, polyethylene, or polyvinylidene chloride. For non-woven fabric the contractor may use needle punched, heat bonded, resin bonded, or combinations of all 3. Sediment control fence shall be made of Mirafi 100 sediment control fabric, backed by industrial polypropylene netting, manufactured by Dominion Textile Company, or equal. For other fabrics contractor shall submit a certificate of compliance certifying that the geotextile conforms to the latest version available on the website of the Wisconsin Department of Transportation Standard Specification for Highway and Structure Construction, Section 628. Posts used to support the fabric shall be at least two (2) inch by two (2) inch in cross-section.
5. Double Sediment Control Barrier: Double sediment control barrier shall consist of a combination of sediment control fence and straw or hay bale erosion control barrier, with the fence being installed on the upstream side of the bales. The bales used in the double sediment control barrier shall be either hay or straw, have rectangular surfaces, and be tightly bound with twine, not wire. The material in the bales shall be reasonably free of grain, weed, seed, and mold, and shall be dry and suitable for the purpose intended.
6. Construction Entrance Material: Material used in construction entrances shall be three (3) inch to six (6) clear crushed stone. All material shall be retained on a 3-inch sieve.
7. Straw or Straw/Coconut Fiber Erosion Control Mat: The straw or straw/coconut fiber erosion control mat shall be a biodegradable machine-produced mat from the latest edition of the Wisconsin Department of Transportation Product Acceptability List for Erosion Mat, Class I, Type B
8. Coconut Fiber Erosion Control Mat: The coconut fiber erosion control mat shall be a machine-produced 100% biodegradable mat with a 100% coconut fiber matrix

listed under the latest edition of the Wisconsin Department of Transportation Product Acceptability List for Erosion Mat, Class II, Type B. The erosion mat shall be of consistent thickness with the coconut fiber evenly distributed over the entire area of the mat. The mat shall be covered on the top and bottom with photodegradable woven netting. The netting shall consist of photodegradable polypropylene square mesh openings of 5/8 inch to 3/4 inch dimension on each side. The blanket shall be sewn together with photodegradable polypropylene thread.

9. Erosion Control Polymer (Soil Stabilizer): Erosion control polymer shall be from the latest edition of the Wisconsin Department of Transportation Product Acceptability List for Soil Stabilizers, Type B. The polymer shall have no odor. The polymer shall be protected from ignition sources and contact with strong oxidizing agents and heat shall be avoided.
10. Temporary Ditch Checks (Wattles): Temporary ditch checks, also called wattles, shall be from the latest edition of the Wisconsin Department of Transportation Product Acceptability List for temporary ditch checks.

## 2.2 ROCK AND GEOTEXTILE MATERIALS

- A. Materials provided under this section shall be in conformance with the requirements of NR 151 of the Wisconsin Administrative Code and Wisconsin Department of Natural Resources best management practices (BMPs).
- B. Rock : Sound, hard and angular shape; well graded; without shale seams, structural defects and foreign substances; with width and thickness greater than one third its length; minimum specific gravity of 2.5, as determined in accordance with AASHTO T-180 and ASTM C-127

## 2.3 CONCRETE MATERIALS

- A. Furnish according to WisDOT Standards.
- B. Furnish according to WDNR NR-151 and WisDOT Standards: As specified in Paragraph 3.2 – Seeding
- C. Mulch: As specified in Paragraph 3.3 – Application of Straw Mulch

## PART 3 - EXECUTION

### 3.1 CONSTRUCTION

- A. Install Work according to WDNR NR-151 Standards for Site Stabilization
  1. Incorporate erosion control devices indicated on the Drawings into the Project at the earliest practicable time.
  2. Construct, stabilize and activate erosion controls before site disturbance within tributary areas of those controls.

3. Stabilize any disturbed area of affected erosion control devices on which activity has ceased and which will remain exposed for more than 14 days.
  4. Stabilize diversion channels, sediment traps, and stockpiles immediately.
- B. Construct, stabilize and activate erosion controls before site disturbance within tributary areas of those controls.
  - C. All activities on the site shall be conducted in a logical sequence to minimize the area of bare soil exposed at any one time.
  - D. All disturbed ground left inactive for seven (7) or more days shall be stabilized by temporary seeding and mulching or by covering, or by other equivalent control measure.
  - E. Water pumped from the site shall be treated by appropriate controls designed and used to remove particles of 100 microns or greater for the highest dewatering pumping rate. If the water is demonstrated to have no particles greater than 100 microns during dewatering operations, then no control is needed before discharge. Water may not be discharged in a manner that causes erosion of the site or receiving channels.
  - F. The Contractor shall construct clear stone entrance pads to the construction site and shall take all other possible precautions to prevent sediment from being tracked onto public or private roadways. Any sediment reaching a public or private road shall be removed by street cleaning (not flushing) before the end of each workday and before any rainfall occurs.
  - G. All storm drain or culvert inlets shall be protected with sediment control fences or equivalent barriers approved by the Engineer.
  - H. Channelized runoff from adjacent areas passing through the site shall be diverted around disturbed areas when necessary. Sheet flow runoff from adjacent areas greater than 10,000 square feet in area shall also be diverted around disturbed areas. Diverted runoff shall be conveyed in a manner that will not erode the conveyance and receiving channels. (Note: Soil and Conservation Service guidelines for allowable velocities in different types of channels should be followed.)
  - I. Sediment control fences or equivalent control measures shall be placed along all sideslope and downslope sides of the site where runoff can reach a surface water course, wetland, or as shown on the Plans or specified in the Special Conditions. If a channel or area of concentrated runoff passes through the site and is not diverted, sediment control fences shall be placed along the channel edges to reduce sediment reaching the channel.
  - J. Any soil or dirt storage piles containing more than ten cubic yards of material should not be located with a downslope drainage length of less than 25 feet to a roadway or drainage channel. If remaining for more than seven (7) days, they shall be stabilized by mulching, vegetative cover, tarps, or other means. Erosion from piles, which will be in existence for less than seven (7) days, shall be controlled by placing hay bales or sediment control fence barriers around the pile. In-street utility repair or construction soil, or dirt storage piles located closer than 25 feet to a roadway or drainage channel must be covered with tarps or a suitable alternative control must be used if exposed for more than seven (7)

days, and storm drain or culvert inlets must be protected with straw bales or other appropriate filtering barriers.

### 3.2 SEEDING

- A. Seeding, where used for erosion control, shall be temporary grass seed as follows:
- |                         |                 |
|-------------------------|-----------------|
| Before June 15          | Annual Oats     |
| June 15 to September 15 | Annual Ryegrass |
| After September 15      | Winter Wheat    |
- B. The Contractor shall apply the seed using a hydroseeder, a power-drawn drill, or spreader, or approved blower equipment with an adjustable disseminating device capable of maintaining a constant measurement rate of material discharge that will insure an even distribution of seed and fertilizer. Seed mixture shall be applied at the rates of 3 lbs/1,000 ft<sup>2</sup>.
- C. Seedbeds shall be maintained in a moist growing condition. When necessary, the Contractor shall soak the seedbed by sprinkling with water.

### 3.3 APPLICATION OF STRAW MULCH

- A. The Contractor shall furnish, haul and evenly apply straw mulch at a rate not less than 1½ tons per acre to a loose depth of one (1) or two (2) inches. Mulch shall be placed loose and open enough to allow some sunlight to penetrate and air to circulate but still cover a minimum of 70% of the soil surface. The mulch spreading equipment shall utilize forced air to blow mulch material onto the seeded area, unless otherwise approved by the Engineer. Where mulch is used, alone, as a temporary cover, the rate of application shall be not less than three (3) tons per acre and shall cover a minimum of 80% of the soil surface.
- B. Unless otherwise designated the Contractor shall anchor the straw mulch by crimping so that the mulch is partially embedded in the soil.

### 3.4 PLACING STRAW OR HAY BALE BARRIERS AS PART OF DOUBLE SEDIMENT CONTROL BARRIER

- A. Sufficient bales shall be on the site to create the necessary barriers before the start of groundbreaking operations. The bales shall be stacked and covered with plastic sheeting until required for use.
- B. The bales shall be placed with the cut side of the bale downward, in a shallow trench excavated for that purpose. The bales shall be fixed in place using reinforcing rod or steel fence posts extending completely through the bale and driven at least 18 inches into the ground. Two (2) rods or posts shall be placed in each bale, one at each ½ point.

- C. If a bale in a barrier is wholly or partially destroyed during the course of the project the Contractor shall, at its own expense, replace the bale with a fresh, unused bale.

### 3.5 CONSTRUCTION OF SEDIMENT CONTROL FENCE

- A. Sediment control fence shall be constructed according to the manufacturer's recommendations, the provisions of the Wisconsin Department of Natural Resources Conservation Practice Standard 1056, and generally as follows:
- B. Excavate a six inch by six inch (6"x 6") trench along the upslope perimeter of the fence location
- C. Unroll the fencing fabric a section at a time and position the posts against the downslope side of the trench, with the fabric on the upslope side of the posts. Drive the posts into the ground until the support netting is approximately two (2) inches from the trench bottom (the fabric should extend several inches below the netting.)
- D. Lay the toe-in flap of fabric onto the undisturbed trench bottom, backfill the trench and tamp the soil down firmly.

### 3.6 INSTALLING STRAW/COCONUT AND COCONUT FIBER EROSION CONTROL MAT

- A. Erosion control mat shall be installed according to the manufacturer's recommendations and generally as follows:
- B. Prepare soil before installing blankets, including any application of fertilizer and seed.
- C. Begin at the top of the channel by anchoring the blanket in a six (6) inch deep by six (6) inch wide trench with approximately 12 inches of blanket extended beyond the up-slope portion of the trench. Anchor the blanket with a row of staples/stakes approximately 12 inches apart in the bottom of the trench. Backfill and compact the trench after stapling. Apply seed to compacted soil and fold remaining 12-inch portion of blanket back over seed and compacted soil. Secure blanket over compacted soil with a row of staples/stakes spaced approximately 12 inches apart across the width of the blanket.
- D. Roll center blanket in direction of water flow in bottom of channel. Blankets will unroll with appropriate side against the soil surface. All blankets must be securely fastened to the soil surface by placing staples/stakes in appropriate locations as recommended by the manufacturer.
- E. Place consecutive blankets end over end (shingle style) with a four (4) to six (6) inch overlap. Use a double row of staples staggered four (4) inches apart and four (4) inches on center to secure blankets.
- F. Full-length edge of blankets at top of side slope must be anchored with a row of staples/stakes approximately 12 inches apart in a six (6) inch deep by six (6) inch wide trench. Backfill and compact the trench after stapling.

- G. Adjacent blankets must be overlapped four (4) inches (depending on blanket type) and stapled.
- H. A staple check slot is required at 30 to 40 foot intervals. Use a double row of staples staggered four (4) inches apart and four (4) inches on center over entire width of the channel.
- I. The terminal end of the blankets must be anchored with a row of staples/stakes approximately 12 inches apart in a six (6) inch deep by six (6) inch wide trench. Backfill and compact the trench after stapling. In loose soil conditions, the use of staples or stake lengths greater than six (6) inches may be necessary to properly anchor the blankets.
- J. Rock Energy Dissipator: Rock shall be fully fractured to the sizes as noted on the details.
- K. Sediment Traps: Sediment traps shall be constructed by the Contractor as necessary to control sediment runoff from the worksite. Locations for all sedimentation basins shall be approved by the Owner or Engineer prior to construction.
- L. Sediment Traps: The Contractor shall construct sediment traps similar to the sediment pond requirements.
- M. Dust Control: The Contractor shall employ measures to reduce or prevent the surface and air transport of dust during construction. Dust control measures for construction activities include minimization of soil disturbance, applying mulch and establishing vegetation, water spraying, surface roughening, applying polymers, spray-on tackifiers, chlorides and barriers.

### 3.7 APPLICATION OF POLYMER (SOIL STABILIZER)

- A. Polymer shall be evenly applied. Minimum application rates shall be as recommended by the manufacturer. Maximum application rates shall be less than the maximum rates allowed by the Department of Natural Resources, if applicable

### 3.8 DIVERSION CHANNELS

- A. Windrow excavated material on low side of channel.
- B. Compact to 95% maximum density.
- C. Install Work according to WDNR NR-151 Standards

### 3.9 ROCK ENERGY DISSIPATOR

- A. Excavate to indicated depth of rock lining or nominal placement thickness. Remove loose, unsuitable material below bottom of rock lining, then replace with suitable material. Thoroughly compact and finish entire foundation area to firm, even surface.
- B. Lay and overlay geotextile fabric over substrate. Lay fabric parallel to flow from upstream to downstream. Overlap edges upstream over downstream and upslope over downslope. Provide a minimum overlap of 18 inches. Carefully place rock on geotextile fabric to produce an even distribution of pieces, with minimum of voids and without tearing geotextile.
- C. Unless indicated otherwise, place full course thickness in one operation to prevent segregation and to avoid displacement of underlying material. Arrange individual rocks for uniform distribution.

### 3.10 FIELD QUALITY CONTROL

- A. INSPECTIONS:
- B. Contractor shall be responsible for all inspections of erosion control provisions from the beginning of the project to stabilization of all disturbed surfaces. Inspections of implemented erosion control best management practices must be performed weekly and within 24 hours after a precipitation event of 0.5 inches or greater which results in runoff. Department of Natural Resources form 3400-187 (Construction Site Inspection Report) shall be used. Inspect erosion control devices on a weekly basis and after each runoff event. Make necessary repairs to ensure erosion and sediment controls are in good working order.

### 3.11 CLEANING

- A. When sediment accumulation in sedimentation structures has reached a point one-third depth of sediment structure or device, remove and dispose of sediment.
- B. Do not damage structure or device during cleaning operations.
- C. Do not permit sediment to erode into construction or site areas or natural waterways.

### 3.12 MAINTENANCE AND REMOVAL

- A. Contractor shall be responsible for maintaining all erosion control items in a functioning manner, replacement (as necessary), and removal of all items once the site has been fully stabilized.

END OF SECTION 31 25 00

## SECTION 32 12 16 - ASPHALT PAVING

### PART 1 - GENERAL

#### 1.1 SUMMARY

##### A. Description of Work Covered by This Section

1. For construction of asphalt over an aggregate base course, the Contractor shall apply an asphaltic pavement consisting of a lower course and an upper course, placed on the prepared base course, to the thickness and cross-sections shown on the Plan Detail Sheets, and to the lines and grades shown on the Plans. Fine grading in preparation for paving will have been completed under Specification Section 32 05 00. Any repair of this fine grading due to damage by poor or excessive drainage, traffic, or other causes shall be part of this paving work.
2. For asphalt overlay or wedging, the Contractor shall apply upper course over the prepared surface to the thickness specified in the Special Conditions or Bid Schedule.



3. Manhole casting adjustment methods are described in Specification Section 33 05 13. The paving contractor shall turn valve boxes to finished grade as part of the paving work without extra payment.
4. The Contractor shall conform to the requirements of the State of Wisconsin Department of Transportation (WisDOT) Standard Specifications for Highway and Structure Construction, most current edition, and all incorporated errata, annotated revisions, and subsequently issued supplemental specifications, except where this specification is stricter, except that verification testing is omitted, Owner density testing in the field and the related incentives and disincentives shall be omitted, binder and tack coat sampling and testing shall be omitted, ride quality testing shall be omitted.
5. The Contractor shall provide and apply an asphaltic tack coat on all existing asphaltic surfaces. The Contractor shall conform to the requirements of the State of Wisconsin Department of Transportation Standard Specifications for Highway and Structure Construction, most current edition, and all incorporated errata, annotated revisions, and subsequently issued supplemental specifications, unless the requirements set forth elsewhere in this section are more stringent.
6. The Engineer may elect to enforce the most stringent testing requirements in these specifications regardless of the tonnage placed under the project.

B. Section Includes:

1. Asphalt materials.
2. Aggregate materials.
3. Asphalt paving base course, binder course, and wearing course.
4. Tack Coat

## 1.2 REFERENCE STANDARDS

- A. American Association of State Highway and Transportation Officials
- B. Asphalt Institute
- C. ASTM International
- D. Wisconsin Department of Transportation (WisDOT Standards) Standard Specifications for Highway and Structure Construction available on the WisDOT website.

### 1.3 SUBMITTALS

- A. Refer to Section 01 33 00 – Submittals
- B. Product Data:
  - 1. Submit product information for asphalt, aggregate and tack coat materials.
  - 2. Submit mix design with laboratory test results supporting design.
  - 3. The formula shall have been derived from tests performed and approved by Wisconsin Department of Transportation within the previous 12 months. A previous mix design using the same aggregates from the same source and using the same brand and type of asphaltic material may be used with the approval of the Engineer. The tests shall have been performed by a qualified, certified testing laboratory.

### 1.4 CLOSEOUT SUBMITTALS

- A. Section 01 70 00 - Execution Requirements and Project Closeout.
- B. Project Record Documents: Refer to Article 7.11 in Section 00 70 00 - General Conditions

### 1.5 QUALITY ASSURANCE

- A. Mixing Plant: Conform to WisDOT Standards
- B. Obtain materials from same source throughout.
- C. Perform Work in accordance with WisDOT Standards.

## PART 2 - PRODUCTS

### 2.1 MATERIALS AND EQUIPMENT

- A. Asphaltic Concrete
  - 1. Unless otherwise specified in the Special Conditions or the Measurement and Payment specification section, the asphaltic materials used in or north of the

following counties shall be LT 58-34S: Trempealeau, Jackson, Clark, Taylor, Lincoln, Langlade, Menominee and Oconto, and shall be LT 58-28S south of the counties listed above.

B. Lower Course Aggregate

1. Unless otherwise specified in the Special Conditions or Measurement and Payment section of the specifications the Contractor shall use hard, durable angular crushed stone conforming to the gradation requirements for nominal 12.5 millimeter aggregate size as specified under the appropriate section of the Wisconsin Standard Specifications for Highway and Structure Construction, latest edition.

C. Upper Course or Surface Course Aggregates

1. Unless otherwise specified in the Special Conditions or Measurement and Payment section of the specifications the Contractor shall use hard, durable angular crushed stone, which, including mineral filler, shall conform to the gradation requirements for nominal 9.5 millimeter aggregate size as specified under the appropriate section of the Wisconsin Specifications for Highway and Structure Construction, latest edition.

D. Tack Coat

1. The tack coat shall be emulsified asphalt, conforming to AASHTO Designation, M140 or M208, as appropriate. The tack coat shall be SS-1, SS-1h, or CSS-1h with the asphalt emulsion diluted with equal parts water.

E. Recycled Asphaltic Materials

1. The mix shall contain no more of such materials than allowed by the appropriate section of the Wisconsin Specifications for Highway and Structure Construction, latest edition.

F. Tack Coat Equipment

1. The Contractor shall furnish and use a pressure distributor capable of applying tack material uniformly, without atomization. He shall provide all tools as necessary to complete the work.

G. Paving Equipment

1. The Contractor shall use hauling, paving and compacting equipment, as specified in the appropriate section of the WisDOT Standards as referenced above.

## PART 3 - EXECUTION

### 3.1 CONSTRUCTION

A. Fine Grading

1. The Contractor shall repair, as necessary, fine-graded unpaved surfaces to the grade shown on the Plans before paving operations begin. Fine grading will have been completed previously in accordance with Section 32 05 00 of these Specifications. Any repair due to traffic, poor or excessive drainage, or other causes shall be the responsibility of the Asphalt Paving Contractor. Soft spots shall be excavated and such cavities and other holes or depressions filled with crushed aggregate base course in accordance with Section 32 05 00 of these Specifications.

B. Tack Coat

1. Construction Methods: The Contractor shall place tack coat in a single operation, but only during daylight hours when the air temperature is 40° Fahrenheit or more and only upon a prepared, existing pavement which is dry and free of loosen dirt, dust or other foreign matter. The tack coat shall not be applied when it appears probable that the surface may be exposed to moisture during the penetration period. Immediately prior to the application of tack coat the prepared base shall be thoroughly swept with a power broom to remove dust and loose dirt. Care shall be taken to avoid overlapping of joints.
2. Heating and Applying Tack Coat Materials: Application Rate: The asphaltic materials shall be heated and applied by equipment suitable for that purpose. The rate of application shall be 0.05 to 0.15 gallons per square yard, with a target application rate of 0.10 gallons per square yard. The amount shall be sufficient to wet, but not flood the surface.
3. Protection of Surfaces: The Contractor shall protect all adjacent surfaces, including curb and gutter, by some method satisfactory to the Engineer, to prevent their being spattered or disfigured by tacking operations. Traffic shall not be permitted on the tack coat until paving has occurred or for a period of time sufficient to allow the tack coat to penetrate and/or evaporate so that vehicles and pedestrians are not spattered. One line of the street shall remain open and untacked at all times. The work shall be properly protected by barricades and flagmen to prevent damage to freshly placed tack coat.
4. Drying Time: Daily application of the tack coat shall be limited to approximately that area of surface which can reasonably be expected to be paved during the same day. The area tacked shall not be paved until a period sufficient to allow for proper penetration and curing has elapsed.
5. Correction of Deficient Work: Any areas containing an excess or deficiency of asphaltic material and any breaks, reveled spots or other unsatisfactory areas in the tack coat shall be corrected prior to paving by the Contractor at his own expense.

C. Paving Prerequisites

1. The Contractor shall place asphaltic paving mixture only on a prepared, firm, and compacted base or foundation course, substantially surface -dry and free and clear of loose and foreign material. The Contractor shall incorporate loose aggregate existing on the roadbed into shoulder construction, if any, or dispose of such aggregates as directed by the Engineer.
2. Holes and depressions in existing paved surfaces which are to be overlaid shall be prepared by removing all loose and defective material from the hole or

- depression and replacing with a hot-mix asphalt patching material, compacted to produce a tight surface conforming to the adjacent area.
3. If any repair work in the fine graded surface is necessary, the Contractor shall proof-roll prepared surfaces to check for unstable areas requiring additional compaction. If the Contractor finds such areas, notification of these unsatisfactory conditions to the Engineer shall be made and paving work shall not begin until such conditions have been corrected.
  4. The Contractor shall not place asphaltic paving mixtures during the calendar period from October 15 to May 1, of the next succeeding year, regardless of temperature, except with the written authorization of the Owner or the Engineer.
  5. Immediately prior to paving, the Contractor shall saw cut all intersecting streets and adjacent pavements to form a straight, vertical joint line.
  6. Asphaltic paving mixtures shall not be placed over frozen subgrade or base or where the roadbed underlying the foundation or base is temporarily unstable from the effects of frost heaving.
  7. The Contractor shall not place asphaltic paving mixtures when it is raining or snowing; any mixture exposed to rain or snow before final rolling which has, in the judgment of the Engineer, been adversely affected thereby, shall be removed and replaced at the Contractor's expense.
  8. The Contractor shall not place asphaltic paving mixtures when the air temperature at the site of work, approximately three (3) feet above the ground in the shade and away from the effects of artificial heat is less than 36° F. The Contractor may place lower layer mixtures at a lower temperature with the Engineer's written approval.

D. Preparation and Transport of the Mixture

1. The paving mixture shall be composed of a homogeneous mixture of coarse and fine aggregate, mineral filler (when required), and asphalt cement heated to the proper viscosity for uniform distribution throughout the mixture.
2. Aggregates shall be fed uniformly to the plant so that surpluses and shortages will not occur, thereby causing breaks in the continuous operation. The aggregate shall be heated to provide a paving mixture temperature immediately after mixing of 300oF, plus or minus 15o. Mixing time shall be sufficient to provide uniformly coated aggregate.
3. Contractor shall deliver the mixture to the paver receiving hopper at a temperature no lower than 275°F (135°C). Contractor shall cover all loads during transport in periods of inclement weather or when the ambient temperature falls below 65°F (18°C).
4. The Engineer may reject asphaltic paving mixture not sufficiently mixed or defective in any manner.

E. Spreading and Finishing

1. The Contractor shall place the asphaltic mixtures by use of self-propelled spreading and finishing machines conforming to the specified requirements to the thicknesses shown on the Plans. The compacted thickness of individual lower courses shall not be greater than three (3) inches nor less than 1¾ inches. The compacted thickness of individual surface courses shall not be greater than 2 inches nor less than 1½ inches.
2. The operating speed of the paving machine when it is placing the asphaltic mixtures shall be consistent and shall not exceed that speed which is appropriate

for the type of paver and type of mixture to produce a uniformly spread and struck-off layer having a dense, smooth texture without any tearing or segregation of the material, and without rolls or bumps in the surface. The speed shall coincide as closely as possible with the rate of delivery of the asphaltic mixture to provide, as nearly as possible, a continuous paving operation. The speed of the paver shall be subject to the approval of the Engineer.

3. Spreading and finishing shall be in accordance with the requirements of the appropriate section of the WisDOT Standards, latest edition.

#### F. Compaction

1. The Contractor shall compact the course thoroughly and uniformly by rolling after spreading and strike-off. The initial rolling shall begin as soon as practical after the mixture is spread but not until the mixture will bear the roller weight without displacement, hair-cracking, or checking. The roller speed shall be slow enough to avoid undue displacement of the mixture. Keep roller wheels moistened to keep the mixture from sticking to them, without using excessive water. Rolling shall begin at the sides and proceed longitudinally parallel to the road centerline, each trip overlapping the previous trip and progressing to the crown of the road, except that when paving abuts a previously placed strip, the longitudinal joint shall be rolled first.
2. The Contractor shall compact with hot hand tampers or vibratory compactors in areas inaccessible to rollers. The Contractor shall not use pneumatic tire rollers for rolling of driveways and other areas where roller tire marks will not roll out smooth.
3. The Contractor shall check the surface after the initial rolling and shall repair displaced areas by loosening and filling, if required, with hot material. Following initial rolling and while the mixture has been compacted to the degree that no further appreciable consolidation is evidenced under the action of the compaction equipment.
4. The Contractor shall perform finish rolling while the mixture is still warm enough for removal of roller marks, and shall continue rolling until all roller marks are eliminated.
5. The lower course shall be compacted to 91½% Laboratory Density as determined by the nuclear density tests performed by a nuclear density technician certified at Level 1 and provided by the Contractor. Where a lower course is constructed directly over base course the compaction shall be 89½% density determined by the same test. The surface course shall be compacted to 91½% density determined by the same test. There will be no incentive pay adjustment for densities above the minimum specified.

#### G. Joints

1. The placing of any course or layer thereof shall be as nearly continuous as possible without joints. The Contractor shall not roll the unprotected end of the freshly laid mixture unless placement is discontinued long enough to permit the mixture to cool. The Contractor shall make joints between old and new pavement and between fresh and previously cooled work so as to ensure bonding for the full depth of the course or layer. When laying is resumed, the Contractor shall clean the contact surfaces and apply emulsified asphalt tack coat. Joints for continuing work shall be formed by cutting back on the previous run so as to expose the full

depth of the course or layer with a ½- to 1-inch vertical notch being created at the top of tapers on all layers. When a new mat is adjoining an old mat, the joint shall be formed by sawcutting the old mat on a straight line to provide a butt joint for the full depth of the new mat. The surface of the two courses or layers shall be co-planer across the joint.

H. Surface Requirements

1. The finished surfaces shall be smooth and true. The Contractor shall test surfaces by means of a 10 foot straightedge laid parallel to the centerline of the road. Irregularities in the binder course surface which vary in excess of ¼-inch from the lower edge of the straightedge between any two contact points shall be corrected.
2. Irregularities in the surface course that vary in excess of ⅛-inch from the lower edge of the straightedge between any two contact points shall be corrected.

I. Asphalt Paving Overlay and Asphalt Wedging

1. Holes and depressions in existing paved surfaces which are to be overlaid shall be prepared by removing all loose and defective material from the hole or depression and replacing with an asphalt-aggregate patching material, compacted to produce a tight surface conforming to the adjacent area.
2. The entire surface to be overlaid shall be thoroughly cleaned with a power broom.
3. The Contractor shall proof-roll prepared surfaces to check for unstable areas requiring additional compaction. If the Contractor finds such areas he shall notify the Engineer of these unsatisfactory conditions and shall not begin paving work until such conditions have been corrected.
4. Place wearing course to compacted thickness identified in the Special Conditions or Bid Schedule.
5. Compact overlay by rolling to specified density. Do not displace or extrude paving from position. Hand compact in areas inaccessible to rolling equipment.
6. Perform rolling with consecutive passes to achieve even and smooth finish, without roller marks.
7. The finished cross-section of the pavement shall have a slope as near as possible to 2%, from center of pavement to the edge, unless otherwise specifically approved by the Engineer or shown on the plans.
8. The edges of wedged areas shall be feathered to blend with the existing pavement. These two surfaces shall be co-planer across the joint so that water will drain from the center of the roadway to the edge rather than standing at the joint or running longitudinally down the roadway.

J. Curbs

1. Install extruded asphalt curbs as indicated on the Plans

K. Maintenance

1. Maintain and protect the work during the various stages of construction until the final acceptance. Any rick or bleeding areas, any breaks, raveled spots, or other unsatisfactory areas in the wearing surfaces shall be corrected during such maintenance period.

L. Traffic; Protection of Work

1. One lane of traffic shall be maintained on the street at all times. Access to private driveways shall not be prevented for more than one 24 hour period. Property owners shall be notified one day in advance of periods of restricted access.
2. The work shall be properly protected by barricades, flares, and flagmen to prevent damage to freshly placed asphalt until the pavement has cooled and hardened, and to prevent damage to vehicles.

M. Alley and Driveway

1. All requirements for grading, compaction and supplementing the base course that are set forth herein for the roadway, also apply to alleys and driveways, and for pavement construction shown on the Plans or specified to be paved.

N. Acceptance Testing

1. For all projects, the Contractor shall provide to the Engineer a sample of the job mix to be kept for future testing if required. The sample shall be of sufficient size to measure asphalt content, aggregate gradation, and volumetrics. The sample shall be taken from the actual mix delivered to the job site.
2. When so determined by the Engineer or the Owner's Authorized Representative the Contractor shall cut samples from the finished pavement at locations selected by the Engineer and restore the surface with new compacted material. The samples shall be tested by a recognized testing laboratory approved by the Engineer for pavement thickness, pavement density, asphalt content, and aggregate gradation. Samples shall extend the full depth of the pavement and shall be not less than 65 square inches.
3. One sample may be required from each day's run. The cutting of the sample, restoration of the surface and testing of the sample shall be incidental to the contract unit price for asphaltic concrete paving.
4. For all projects, the Contractor shall submit test results for the mixtures used from the manufacturer's Quality Management Program. Such tests shall be performed under the supervision of a Certified Asphaltic Technician. Such tests shall include aggregate gradation, percent asphalt content, and air voids.

O. Guarantee

1. The Contractor shall guarantee all materials and workmanship for one year from the date of approval of the final payment request by the Owner. This guarantee shall cover, but not be limited to, edge cracking, block cracking and raveling. Defects appearing within that period shall be corrected by the Contractor at his own expense.



3.2 PREPARATION

- A. Prepare subbase in accordance with WisDOT Standards

3.3 DEMOLITION

- A. Saw cut and notch existing paving as shown on the Plans or as required by the Engineer.
- B. Clean existing paving to remove foreign material, excess joint sealant and crack filler from paving surface.
- C. Repair surface defects in existing paving to provide uniform surface to receive new paving.

3.4 FIELD QUALITY CONTROL

- A. Refer to Section 01 40 00 – Quality Requirements
- B. Refer to Section 01 70 00 – Execution Requirements and Project Close-Out

3.5 PROTECTION

- A. Refer to Section 01 70 00 – Execution Requirements and Project Close-Out

END OF SECTION 32 12 16

## SECTION 32 16 23 - SIDEWALKS

### PART 1 - GENERAL

#### 1.1 SUMMARY

- A. Description of Work Covered by This Section
- B. This section describes the methods by which and the materials from which the Contractor shall construct concrete sidewalks. Included in this work is the construction of sidewalk ramps with surface corrugations and thickened sidewalk sections at alleys and driveways.
- C. The Contractor shall construct sidewalk ramps in accordance with Section 66 .6 16 of Wisconsin Statutes and any applicable standards of the municipality.
- D. This section covers framework for cast-in-place concrete, including shoring for concrete work and installation into the formwork of items furnished under other Sections of these specifications such as anchor bolts, setting plates, bearing plates, anchorages, inserts, frames, and other accessory items embedded in the concrete.
- E. This section describes concrete accessories, such as curing compounds, to be used and the methods to be followed in such use.
- F. Section Includes:

- G. Formwork for concrete sidewalks.
- H. Concrete paving for sidewalks.
- I. Curing and finishing concrete sidewalks.

#### 1.2 FORMWORK - CODES AND STANDARDS

- A. Unless otherwise indicated in the Special Conditions the Contractor shall comply with the American Concrete Institute (ACI) Standard 347, "Recommended Practice for Concrete Formwork".

#### 1.3 FORMWORK - DESIGN

- A. Design of formwork, shoring and accessories shall be the responsibility of the Contractor. He shall design, erect, support and maintain formwork to safely support all vertical and lateral loads until such loads can be supported by the concrete structure, as determined in accordance with ACI 347.

#### 1.4 REFERENCE STANDARDS

- A. American Association of State Highway and Transportation Officials
- B. American Concrete Institute
- C. ASTM International
- D. Wisconsin Department of Transportation (WisDOT Standards) Standard Specifications for Highway and Structure Construction available on the WisDOT website

#### 1.5 PREINSTALLATION MEETINGS

- A. A. Refer to Article 2.04 in Section 00 70 00 – General Conditions.

#### 1.6 SUBMITTALS

- A. Refer to Section 01 33 00 – Submittals

## 1.7 QUALITY ASSURANCE

- A. Perform Work according to Section 03 30 01 – Cast-in-place Concrete – Municipal
- B. Perform work in accordance with these Specifications and all applicable local, State and Federal regulations.

## PART 2 - PRODUCTS

### 2.1 MATERIALS AND EQUIPMENT

- A. Forms - The forms used in constructing sidewalk shall be made of steel, plastic or wood and shall be of sufficient size and strength to resist movement during placement of concrete and to retain alignment and grade. Straight section wood forms shall be at least two (2) inches in nominal thickness. Curved sections of sidewalk shall be constructed using flexible spring steel forms or laminated boards.
- B. Gravel Base - Gravel used for base under sidewalks shall be  $\frac{3}{4}$  inch dense graded base as specified in Section 301 of the WisDOT Standards, as set forth on the Department of Transportation website.
- C. Concrete - Concrete shall be Class BB, as specified in Section 03 30 01 of these specifications.
- D. Expansion Joint Filler - Expansion joints shall be created using pre-molded joint filler, bituminous fiber type or asphalt impregnated type, ASTM D1751. The filler material shall be three-quarters ( $\frac{3}{4}$ ) of an inch in thickness and of sufficient size to provide a continuous joint from the top surface to the bottom surface of the sidewalk and from one side of the walk to the other.
- E. Curing Compound
  - 1. The compound shall be such that the coating formed by its application on concrete surfaces will provide an effective seal for at least 10 days. It shall adhere firmly to concrete, either partially set or hardened, and shall be ready-mixed for immediate use without alteration other than stirring.
  - 2. Liquid membrane-forming compounds used for curing concrete under normal conditions shall conform to ASTM C309 or AASHTO M148, and shall be one of the following, or approved equal:
    - a. Horn Clear Seal - W. R. Grace Construction Products
    - b. Sealtite Cure and Seal CS309 - W. R. Meadows, Inc.

- c. Eucocure - Euclid Chemical Company
  - d. Kure-N-Seal - Sonneborn Building Products
  - e. L & M Cure - L & M Construction Chemicals, Inc.
- F. Forms for Exposed Finish Concrete - Unless otherwise designated, the Contractor shall construct formwork for exposed concrete surfaces with plywood, metal, metal-framed plywood, or other panel type acceptable to the Engineer. The forms shall provide continuous, straight, smooth surfaces. The Contractor shall furnish panels in the largest practicable sizes to minimize the number of joints. He shall provide form material of sufficient stiffness to withstand pressure of newly placed concrete without bow or deflection. When using board formwork for architectural pattern finish, the Contractor shall replace all boards with tie holes before each reuse.
- G. Plywood Forms - Form plywood shall be Douglas Fir, 5 ply "Plyform", mill treated, edge sealed, water resistant plywood made for this purpose, free of loose knots, splits, checks, or excessive raised grain.
- H. Form Coating Compounds - Form coating compounds shall be commercial formulations that will not bond with, stain, nor adversely affect in other ways the concrete surfaces. Form coating compounds shall not impede the wetting of surfaces to be cured with water or curing compounds. Forms for concrete surfaces requiring subsequent treatment shall receive a type of coating that will not impair bond or adhesion. Form oil used on steel forms shall be non-staining, rust preventative type.
- I. Moisture-Retaining Cover - When curing and sealing compounds are not used the Contractor shall provide one of the following moisture-retaining covers which comply with ASTM C171:
- 1. Waterproof paper
  - 2. Polyethylene film
  - 3. Polyethylene-coated burlap
- J. Truncated Dome Warning Plates – Truncated Dome Warning Plates shall be unpainted 24" x 36" gray cast iron detectable warning plates for embedment in sidewalk ramps in accordance with Section 4.29 of the ADA Accessibility Guidelines. The cast iron shall conform to ASTM A-48, Class 30A minimum. The plates shall have 0.2-inch high truncated domes with a base diameter of 0.9 inches to 1.4 inches, and a top diameter of 50% to 65% of the base diameter. These domes shall be located at a center-to-center spacing of 1.6 inches to 2.4 inches, and a minimum base-to-base spacing of 0.65 inches in a square grid pattern. The plates shall be as provided by Neenah Foundry Company.

## 2.2 SOURCE QUALITY CONTROL

- A. Section 01 40 00 - Quality Requirements: Requirements for testing, inspection, and analysis.
- B. Testing: Comply with ASTM C94.

## PART 3 - EXECUTION

### 3.1 CONSTRUCTION

#### A. Removal of Obstructions – Clearing and Grubbing

1. The Contractor shall remove all old sidewalk, curb and gutter, driveways, pavements, drains, trees, shrubs and any other items necessary to allow construction of the new sidewalks.
2. Tree roots shall be removed to a depth of 12 inches below the bottom of the sidewalk sand or gravel base materials and shall be cut at a point at least 12 inches horizontally from the finished edge of the sidewalk. Holes left from the removal of trees or obstructions shall be backfilled with sand and shall be thoroughly compacted and moistened before concrete is placed. All removed trees and obstructions shall be disposed of at a location outside the project area, such location and manner of disposal being acceptable to the Owner and in conformance with applicable solid waste disposal regulations.

#### B. Excavation, Backfilling, and Grading

1. The Contractor shall excavate or backfill as necessary to meet the line and grades established in the field by the Owner, shown on the Plans, defined in the Special Conditions, or defined in these specifications. All existing sod, pavements, and other surface materials obviously unsuitable for subgrade materials shall properly be removed and disposed. The Contractor shall notify the Engineer at least three working days in advance of his need for lines and grades. Where lines and grades are staked in the field stakes will be provided at an offset convenient for the Contractor at 50-foot intervals. Where curb & gutter exists, the top of curb shall be used for grade.
2. The costs of excavation and backfill shall be incidental to the unit bid price for concrete sidewalk being constructed in that location, unless the materials being excavated are being removed after the surface sod, pavements, etc., have been removed, are below the subgrade, are unsuitable for subgrade materials and are ordered removed by the Engineer. In such cases, an extra payment shall be negotiated as provided in the General Conditions.
3. Obstructions shown on the Plans or visible from the ground surface prior to clearing and grubbing and which can reasonably be expected to be removed in order for construction of new sidewalk will not be basis for extra payment. Nor will extra payment be allowed for excavations below grade or for backfill materials required to fill such excavations when such excavation is caused by negligence of the Contractor.
4. Backfilling shall be accomplished by placing approved backfill materials in lifts not to exceed 12 inches. Each lift shall be mechanically compacted to a density greater than or equal to 95% of maximum density as determined by the Modified Proctor test or by AASHTO Designation: T99, Method C, with replacement of the fraction of material on the ¾-inch sieve with No. 4 to ¾-inch material. The Owner shall pay for the first series of compaction tests, if such tests are ordered by the Engineer. If the compaction tests fail the Contractor shall recompact those areas and shall pay for the compaction tests on the recompact areas.

5. After completion of necessary excavation and/or backfilling the Contractor shall grade the subgrade to within one inch of established grade and the area between the sidewalk and the adjacent property line shall be shaped to line, grade and section shown on the Plans, in the details at the end of this section, or defined in the Special Conditions. He shall remove all loose material from the subgrade, proof roll the subbase to check for unstable areas needing additional compaction and shall furnish the compacted subgrade to a true, uniform and smooth surface. Unless a payment item is provided for restoration all work in the boulevard area or in the area between the sidewalk and the adjacent property line shall be incidental to the payment for sidewalk.

C. Base Preparation

1. The Contractor shall provide a crushed aggregate base to a minimum six (6) inch thickness for all sidewalks, unless otherwise shown on the Plans or specified in the Special Conditions. These materials shall be compacted as required for backfill in the previous subsection and shall be fine graded to the established grade. Any valve or curb stop boxes, catch basins, manholes or other utility appurtenances which exist within the limits of the sidewalk construction shall be adjusted to the finished grade at no extra cost so that the new construction will not interfere with the proper operation of the facility.
2. The base shall be thoroughly dampened before the time the concrete is placed. It is the sole responsibility of the Contractor to arrange for the water necessary for such dampening. No extra payment will be made for water or for the dampening process.

D. Form Construction

1. The Contractor shall set the forms to the required grades and lines, rigidly brace the forms, and secure them. Where the Owner selects to provide no line and grade, such as in cases where individual sections of existing walks are being replaced, it is the Contractor's sole responsibility to establish his own line and grade to construct the sidewalk in such a manner as to blend, both horizontally and vertically, with the existing walks or pavements.
2. Unless otherwise shown on the Plans or specified or ordered by the Engineer, where the new sidewalk is being constructed adjacent to a street with existing curb and gutter the sidewalk shall be constructed at a grade at the front of the walk 0.3 foot higher than the grade of the top of the curb.
3. Tolerances for formwork grade and alignment, and for the resulting finished sidewalk, from the established line and grade, from 0.3 foot above the adjacent top of curb, or from the existing walks or pavements with which the new sidewalk is being blended shall be as follows:
  - a. Alignment and Grade Tolerance - Less than or equal to ¼-inch
  - b. Surface Variation - Less than or equal to ¼-inch in 10 feet
  - c. Vertical and /or Horizontal - Less than or equal to ¼-inch
4. Joint Displacement With Reference to Existing Walks or Pavements- Variations greater than those specified above shall be grounds for rejection of the work.

Rejected work shall be removed and replaced by the Contractor at no cost to the Owner.

5. Unless otherwise shown on the Plans, where new sidewalks are being constructed adjacent to a street, the forms shall be set and the sidewalk constructed with a transverse slope of ¼-inch per foot, toward the street side of the walk.
6. Formwork shall be properly braced or tied together so as to maintain position and shape and insure safety to workman and passersby.
7. The Contractor shall coat steel forms with form oil or otherwise protect against rusting. Rust-stained steel formwork will be rejected.
8. The Contractor shall coat the surfaces of forms which will contact the concrete to be poured with form coating compound before concrete is placed. He shall not allow excess form coating material to accumulate in the forms or to come into contact with existing concrete against which fresh concrete will be placed. He shall apply form coatings in compliance with the instructions of the manufacturer of the coating compound.
9. The Contractor shall clean and repair surfaces of forms to be re-used in the work. Split, frayed, delaminated or otherwise damaged form facing materials are not acceptable for re-use. The Contractor shall apply new form coating compound to concrete surfaces of forms to be re-used, just as is specified herein for new framework.
10. The Contractor shall assemble forms so their removal will not damage the concrete.

E. Joints

1. The Contractor shall construct weakened plane (contraction), expansion and construction joints with faces perpendicular to the sidewalk surface and transverse (at right angles) to the centerline of the walk, unless otherwise shown on the Plans or specified in the Special Conditions.
2. The Contractor shall provide expansion joints at not more than 96-foot centers and as shown on the plan detail sheets. Joint fillers shall extend the full width and depth of the joint, terminating not less than two (2) inches nor more than one (1) inch below the top surface of the finished sidewalk. On the sides of the walk, the joint filler shall be trimmed even with the concrete.
3. Joint fillers shall be provided in one-piece lengths, except as approved by the Engineer. Where more than one piece of joint filler is allowed the Contractor shall lace or clip together the sections of the filler.
4. Weakened plane (contraction) joints shall be formed by grooving the fresh concrete to a depth of at least ¼ of the walk thickness with a cutting tool. Transverse joints, either weakened place or expansion, shall be spaced at five foot centers.
5. Joints shall be matched to joints in adjacent driveways and curbs.

F. Concrete Thickness and Placement

1. Sidewalk thickness is shown on the Plan Detail Sheets, in the Special Conditions, Measurement and Payment Section, or in the Bid Proposal.
2. Concrete shall be placed and cured in accordance with the requirements of Section 03 30 01 Cast In Place Concrete – Municipal of these specifications.



The Contractor shall also comply with the provisions of that section and with Subsection 2.1C of this section with regard to proportioning, mixing, and testing. The Contractor shall not place the concrete until the subgrade and forms have been checked for line and grade. He shall moisten the subgrade as required to provide a uniform dampened condition at the time the concrete is placed.

3. The Contractor shall spread the concrete uniformly between the forms and shall strike it off and thoroughly compact it with a steel shod strikeboard.

#### G. Finishing Concrete

1. After the concrete has been thoroughly compacted and leveled, it shall be floated with wood or metal floats to smooth the surface and to eliminate irregularities and honeycombed areas. The surface shall be tested for trueness with a 10 foot straightedge.
2. Joints shall be edged with a  $\frac{1}{8}$  to  $\frac{1}{4}$ -inch radius edger. Sidewalk edges shall be tooled with a  $\frac{1}{4}$  to 2-inch radius edger.
3. The Contractor shall then create a brushed finish using a fiber-haired brush drawn transversely to the centerline of the sidewalk, except at driveway and alley crossings where the brush finish shall be longitudinal to the centerline of the walk.
4. The Contractor shall wet cure or cure finish the concrete with a white pigmented curing compound meeting the requirements of Subsection 2.1E.

#### H. Curb Ramps

1. The Contractor shall construct curb ramps at all intersections. Such ramps shall be Type 1, as shown on the ramp detail on the plans in all areas where the distance from the back of the curb to the back of the sidewalk is less than 12 feet. Type 2 curb ramps as shown on the plans shall be constructed in all areas where the distance from the back of the curb to the back of the sidewalk is 12 feet or greater, unless otherwise shown on the Plans or specified in the Special Conditions.
2. All ramps shall have a surface texture. Unless a truncated dome detectable panel is specified in the Bid Proposal, the Special Conditions or the Measurement & Payment Section, surface texturing shall consist of linear impressions approximately  $\frac{1}{4}$ -inch to  $\frac{3}{8}$ -inch in depth and width, oriented to provide a uniform pattern of diamond shapes measuring approximately  $1\frac{1}{4}$  inches in width by  $2\frac{1}{4}$  inches in length, with the length being parallel to the direction of pedestrian movement. This surface texture may be achieved by impressing and removing a piece of expanded metal regular industrial mesh into the surface of the ramp while the concrete is in a plastic state. If state or federal codes require a surface texture at variance with this requirement, those codes shall govern.

#### I. Alleys and Driveways

1. Sidewalks at alleys and driveways shall be constructed to the minimum thickness shown on the plan detail sheet. Transverse slopes of sidewalks at driveways and alley entrances shall match the slope of the driveway or alley ramp, but shall not exceed 5%.

2. Where a new concrete driveway pavement joins an existing concrete driveway pavement with at least a 7-inch average thickness, the two pavements shall be joined by drilling ties made of No. 4 reinforcing rod at least six inches into the existing pavement at the midpoint of the thickness and extending those ties at least six inches into the new pavement. Ties shall be placed at 24 inches on center or closer. These ties shall be paid on a per tie basis separately from the concrete sidewalk or driveway.

J. Restoration of Boulevard Areas and Embankment and Excavation Slopes]

1. The Contractor shall finish all boulevard areas and embankment and excavation slopes to the blend lines or points shown on the plans or plan cross-sections. If only blend points are shown on plan cross-sections the Contractor shall, for bid purposes, interpolate between adjacent sections. For blend areas, where topsoil cover will be greater than two (2) inches, the existing sod shall be removed before new topsoil is placed. The Contractor shall also repair all other areas he has disturbed. Restoration shall be in accordance with the provisions of Section 32 90 00.

K. Protection

1. The Contractor shall protect sidewalk from damage until acceptance of the work. The Contractor shall exclude traffic from sidewalk for at least 7 days after placement and shall repair or replace broken or defective sidewalk as directed. He shall make provisions for pedestrians and vehicular traffic both during construction and during the 7 day traffic exclusion period using whatever barricades, warning signs, lanterns, and lights may be necessary.

L. Guarantee Period

1. The Contractor shall guarantee the sidewalk to remain free from cracks, chips, and spalling due to weather related or settlement causes for a period of one year from acceptance. The Owner may inspect the sidewalk after it has passed through the first winter for such defects and may call the Contractor back to the project area to repair or replace broken, cracked, chipped or defective sidewalks at no cost to the Owner.

M. Section 01 70 00 – Execution Requirements and Project Closeout: Requirements for installation examination.

3.2 FIELD QUALITY CONTROL

- A. Section 01 40 00 - Quality Requirements: Requirements for inspecting and testing.

PART 4 - MUNICIPAL REQUIREMENTS

4.1 TRUNCATED DOME PANELS

- A. Truncated domes are not required unless listed in the bid proposal.

4.2 SYNTHETIC FIBER REINFORCEMENT

- A. Synthetic fiber reinforcement is not required unless listed in the bid proposal.

END OF SECTION 32 16 23

## SECTION 32 16 25 - CONCRETE CURB & GUTTER

### PART 1 - GENERAL

#### 1.1 SUMMARY

##### A. Description of Work Covered by This Section:

1. The Contractor shall construct curb & gutter, curb transitions, gutter sections for ramps for the handicapped, drive-over gutter sections, and incidental appurtenances. The Contractor shall construct these structures in the locations and to the lines and grades shown on the Plans. The work includes protecting the curb and gutter against damage until restoration is complete.
2. The Contractor shall construct the curb and gutter in accordance with the provisions of the current edition of the State of Wisconsin Department of Transportation, Standard Specifications for Highway and Structure Construction, latest version, as set forth on the Department of Transportation website, and in conformance with Wisconsin Statutes, 66.0909, Curb Ramping.

##### B. Section Includes:

1. Concrete paving for curb and gutter
2. Parking Bumpers

## 1.2 REFERENCE STANDARDS

- A. American Association of State Highway and Transportation Officials
- B. American Concrete Institute
- C. ASTM International
- D. Wisconsin Department of Transportation (WisDOT Standards) Standard Specifications for Highway and Structure Construction available on the WisDOT website

## 1.3 PRE-INSTALLATION MEETINGS

- A. Refer to Article 2.04 in Section 00 70 00 – General Conditions

## 1.4 SUBMITTALS

- A. Refer to Section 01 33 00 – Submittals

## 1.5 QUALITY ASSURANCE

- A. Perform work in accordance with these Specifications and all applicable local, State and Federal regulations.
- B. Perform Work according to WisDOT Standards

## PART 2 - PRODUCTS

### 2.1 MATERIALS & EQUIPMENT

- A. Concrete: The Contractor shall use concrete that complies with the specifications for Type BB concrete as set forth in Section 03 30 01 of these specifications. Special care shall be taken to use aggregates that yield concrete of the proper workability for this application.
- B. Forms
  - 1. Forms may be either stationary or slip-type forms. If machine pavers and slip forms are used for placing, forming, and consolidating the concrete, the finished curb and gutter shall be of quality equal to that produced by stationary forms and the methods described below.
  - 2. Forms for straight sections shall be steel and shall be straight and free from defects. They shall be of such size and strength that when properly supported they can resist movement in any direction during concrete placement and can retain horizontal and vertical alignment. Bent, warped, split, or defective form materials are not permitted. Forms shall be full depth of curb and gutter sections.
  - 3. The Contractor shall use flexible spring steel forms or laminated boards to form radius sections.
- C. Joint Fillers: Joint fillers shall be used in expansion joints and for joints between the curb and existing sidewalk or other structures. Such fillers shall be pre-molded joint fillers, bituminous fiber type, or asphalt-impregnated felt type, complying with ASTM D1751 or AASHTO Designation M213. Such fillers shall be ½-inch in thickness and shall extend the full depth of the concrete. Pre-molded joint fillers shall be kept on a flat surface in storage before insertion in the concrete. No warped or damaged material shall be used.
- D. Curing Compound: Curing compound shall be wax resin, white-pigmented, conforming to the requirements of ASTM C309, Type 2. It shall be ready-mixed for immediate use without alteration other than stirring. It shall adhere firmly to concrete, either partially set or hardened.
- E. Granular Base Course: Base course materials shall comply with the materials specification paragraphs in Section 32 05 00 of these specifications.

### 2.2 CONCRETE BUMPERS

- A. Cement: ANSI/ASTM C150, Portland Type I; gray color
- B. Concrete Materials: ASTM 33 and ASTM330 for water and sand.
- C. Reinforcing Steel: ASTM A615/A615M, 40 ksi yield grade, plain billet bars, uncoated finish, strength and size commensurate with precast unit design.
- D. Air Entrainment Admixture: ANSI/ASTM C260.

- E. Concrete Mix: Minimum 5000 psi, 28-day strength, air entrained to 5% to 7%.
- F. Use rigid molds, constructed to maintain precast units uniform in shape, size and finish. Maintain consistent quality during manufacture.
- G. Embed reinforcing steel, and drill or sleeve for 2 dowels.
- H. Cure units to develop concrete quality, and to minimize appearance blemishes including non-uniformity, staining, or surface cracking.

### 2.3 BUMPER ACCESSORIES

- A. Dowels: Cut reinforcing steel,  $\frac{5}{8}$ -inch diameter, 36-inch long, pointed tip.

## PART 3 - EXECUTION

### 3.1 CONSTRUCTION

- A. Curb and Gutter Conformation: The Contractor shall construct curb and gutter to the conformations shown for Standard Curb and Gutter in detail shown on the Plan detail sheets except for drive-over curb, where noted on the Plans or ordered by the Engineer in the field and where sidewalk ramps are required. If curb and gutter terminates at a ditch, the Contractor shall construct a flared flume to match the topography.
- B. Line and Grade:
  - 1. Line and grade shall be as shown on the Plans and as shown on the Plan detail sheet. The Contractor shall notify the Engineer at least three (3) working days in advance of his need for lines and grades. Stakes will be provided at 25-foot intervals at an offset convenient to the Contractor. All stakes and reference marks shall be carefully preserved by the Contractor. If these marks are disturbed, they shall be replaced at the Contractor's expense.
  - 2. Care shall be taken to provide a uniform grade. The Contractor shall carefully check the grade and shall report irregularities to the Engineer. Deviations from established lines and grades shall be cause for rejection of all or part of the work.
- C. Clearing and Grubbing, Removal of Obstructions
  - 1. The Contractor shall coordinate with the local postmaster regarding relocation of mailboxes during the construction period. The Contractor shall, incidentally to the curb & gutter bid items, temporarily move such mailboxes as required by the local postmaster and shall permanently reinstall such mailboxes in locations and at elevations acceptable to the local postmaster and the property owner.
  - 2. The Contractor shall cut and dispose of trees and shrubs, remove and dispose of roots, stumps, old curb and gutter, sidewalks, driveways, pavements, drains and other obstructions in the curb area, as necessary to complete the construction as shown on the Plans. Roots of trees shall be cut at a point at least one (1)-foot from the nearest surface of the curb and gutter. Any items or materials of apparent

value, such as culvert pipes, shall be salvaged for the Owner and transported to a location designated by the Owner, such location being within the municipality. Holes remaining from the removal of obstructions shall be filled with granular subbase course or crushed aggregate base course, and such fill material shall be thoroughly compacted.

D. Excavation, Backfilling and Grading

1. The Contractor shall excavate or backfill as necessary to meet the line and grades established in the field by the Owner, shown on the Plans, defined in the Special Conditions, or defined in these specifications. All existing sod, pavement, and other surface materials obviously unsuitable for subgrade materials must be removed and disposed.
2. The costs of excavation and backfill shall be incidental to the unit bid price for curb & gutter being constructed in that location, unless the materials being excavated are being removed after the surface sod, pavements, etc., have been removed, are below the subgrade, are unsuitable for subgrade materials and are ordered removed by the Engineer. In such cases, an extra payment shall be negotiated as provided in the General Conditions.
3. Obstructions shown on the Plans or visible from the ground surface prior to clearing and grubbing and which can reasonably be expected to be removed in order for construction of new curb & gutter will not be basis for extra payment. Nor will extra payment be allowed for excavations below grade or for backfill materials required to fill such excavations when such excavation is caused by negligence of the Contractor.
4. Backfilling shall be accomplished by placing  $\frac{3}{4}$  inch crushed aggregate material in lifts not to exceed 12 inches. Each lift shall be mechanically compacted to a density greater than or equal to 95% of maximum density as determined by the Modified Proctor test or by AASHTO Designation: T99, Method C, with replacement of the Fraction of material on the  $\frac{3}{4}$ -inch sieve with No. 4 to  $\frac{3}{4}$ -inch material. The Owner shall pay for the first series of compaction tests, if such tests are ordered by the Engineer. If the compaction tests fail, the Contractor shall re-compact those areas and shall pay for the compaction tests on the re-compact areas.

E. Base Preparation

1. The Contractor shall fill all holes and depressions with crushed aggregate base course, compact this backfill, and smooth the surface of the subgrade. The Contractor shall place four (4) inches of crushed aggregate base course under the entire curb and gutter area and to a point one (1)-foot beyond the front and back faces of the curb and gutter.
2. If it is specified in the Special Conditions that the base course will be placed by another contractor in the process of construction of a new street, the Contractor shall grade and thoroughly compact the base to the foundation elevation necessary to construct the curb and gutter. The Contractor shall thoroughly moisten the surface of the base course and lightly oil the forms immediately before placing the concrete.
3. The Contractor shall also, before placing the concrete, adjust valve boxes, curb stops, storm water inlets, manhole frames and other utility structures to finished grade of new construction in a manner such that the new construction will not



interfere with proper operation of the structures. Storm water inlets and manhole frames shall be adjusted by removing or adding concrete adjusting rings or masonry and then fixing them in place with a collar of concrete masonry. Storm water inlets shall be adjusted with a 1" PVC drainage pipe being incorporated from the base course on the street side of the inlet, through the adjusting ring to the inside of the inlet.

F. Forms

1. The Contractor shall set the forms to the required lines and grades and brace and secure the forms to assure rigidity. The Contractor shall use sufficient forms to allow continuous progress of the work and to permit the forms to remain in place for at least six hours after concrete placement.
2. The vertical face of the forms shall not vary from the established line by more than one (1) inch, and the change in line of the vertical face shall not exceed ¼-inch in 10 lineal feet of curb. The top of the curb shall not vary from the established grade more than ½ inch, and the change in grade of the top of the curb relative to the established grade shall not exceed ⅛-inch in 10 lineal feet.
3. Slip forming methods shall produce equivalent results.

G. Joints

1. The Contractor shall construct expansion, contraction, and construction joints with faces perpendicular to the curb surface and at right angles to the curb line.
2. Expansion joints shall be constructed at each end of radius sections; at about three (3) feet from one side of abutting storm water inlets, at abutting walks, structures, and other fixed objects; and at 300-foot centers. Where practical, expansion joints in the curb should be placed at the same locations as existing expansion joints in adjacent pavements.
3. The Contractor shall extend joint fillers the full width and depth of expansion joints. Such fillers shall terminate not less than ½-inch or more than one (1) inch below the under-surface of the curb and gutter. Joint fillers shall be in one piece, wherever possible. Where more than one piece is required, the Contractor shall lace or clip joint filler sections together.
4. The Contractor shall construct contraction joints consisting of a slot or groove at least two (2) inches in depth by ¼-inch in width, at not less than six (6) nor more than twelve (12)-foot intervals, and at two (2) feet from the top of the flare on each side of driveway aprons, at about three (3) feet from the side of street inlets opposite the side on which the expansion joint is placed. When machine methods are used for forming and finishing, the Contractor shall saw construction joints or create planes of weakness by insertion of partial separator plates having a minimum depth of two (2) inches. The depth of cut and the equipment used in sawing shall be done as soon as practical after the concrete has set sufficiently to preclude raveling during the sawing and before any shrinkage cracking takes place in the concrete. If this method results in random cracking, the Contractor shall use separator plates. Separator plates shall be removed as soon as practical after the concrete has been struck off, consolidated, and set sufficiently to preserve the shape and width of the joint.

- H. Curb Ramping: The Contractor shall provide transitions and gutter sections to accommodate ramps at all intersections. (See the Plan Detail sheet.)

- I. Driveover Sections: At all driveway and alley entrances and at other locations designated on the Plans the Contractor shall construct driveover sections as shown on the Plan detail sheet.
- J. Curb and Gutter Terminations: Where curb and gutter ends, including at the ends of radius sections, the Contractor shall create a transition section in which the curb back is brought down to the gutter elevation. The length of the transition shall be as indicated in Part 4 and on the Plan Detail. These transition sections may not be shown on the Plans and will be in addition to the length shown on the Plans. The transition section shall be separated from the standard curb and gutter by means of a contraction joint.
- K. Concrete Placement: The Contractor shall comply with the requirements of Section 03 30 01 for proportioning, mixing, testing, and placing concrete. The Contractor shall not place concrete until the base on which the curb and gutter will be poured and the forms have been checked for line and grade. The Contractor shall clean the forms before each use and coat them with non-staining form release agent to insure separation from concrete without damage, or discoloration to the concrete. He shall moisten the base, as required to provide a dampened condition at the time concrete is placed. Concrete shall not be placed around structures and frames until they have been brought to the required grade and alignment.
- L. Finishing
  - 1. The Contractor shall test the surface for trueness with a 10-foot straightedge. He shall distribute concrete as required to remove surface irregularities and honeycombed areas, and shall float repaired areas to provide a continuous, smooth finish.
  - 2. The work shall be performed in a manner that results in curb and gutter uniform in appearance and structurally sound. Curbs found with unsightly bulges, ridges, low spots in the gutter or other defects shall be removed and replaced at the Contractor's expense if the Engineer considers them to be irreparable.
  - 3. The faces of the curb and gutter shall be thoroughly troweled and brushed. The Contractor shall round the edges of gutters, the back edge of curb and edges adjacent to expansion and contraction joints with a 1/8-inch to 1/4-inch radius edging tool. The Contractor shall then eliminate any tool marks on the concrete surface.
  - 4. The Contractor shall create a brushed or broomed finish unless otherwise designated on the Plans or in the Special Conditions. After excess moisture (surface sheen) has disappeared, the Contractor shall provide this finish by drawing a fine-hair broom across concrete surfaces perpendicular to the line of traffic. The brooming operation shall be repeated if required to produce a fine-line texture.
  - 5. After removal of forms, the Contractor shall repair honeycombed and defective area with Portland cement grout.
- M. Curing: The concrete shall be protected against excess loss of moisture and rapid temperature changes by use of approved curing methods. The Contractor shall wet cure the concrete using waterproof paper or white polyethylene sheets, or shall cure-finish the concrete with curing compound. If curing compound is used the Contractor shall apply it at a rate of 200 square feet per gallon to all formed surfaces immediately after the forms are removed. If the curing compound is damaged by rain or any other cause, it shall be restored to the original condition by reapplication.

- N. Restoration of Adjacent Areas: The Contractor shall restore all surfaces or disturbed areas accordance with the provisions of Section 32 90 00, but at least to the condition which existed before construction. Restoration shall continue from the curb to the blend lines or points shown on the plans or plan cross-sections. If only blend points are shown on the plan cross sections the Contractor shall, for bid purposes, interpolate between adjacent sections. For blend areas where topsoil cover will be greater than two (2) inches, the existing sod shall be removed before new topsoil is placed. Contractor shall leave a small amount of additional topsoil on each side of driveways to be restored with asphalt to allow property owners to blend topsoil to the edge of the driveway after the paving has been completed. If base course exists on the street side of the gutter the Contractor shall backfill and compact this base course adjacent to the new gutter so that the base course is suitable for subsequent paving and as necessary to protect the new curb and gutter. He shall backfill and grade the complete area from the curb to the sidewalk or property line. He shall provide four (4) inches of topsoil and shall apply fertilizer, seed, and mulch.
- O. Bumper Installation
1. Install units without damage to shape or finish. Replace or repair damaged units
  2. Install units in alignment with adjacent work.
  3. Fasten units in place with two (2) <sup>5</sup>/<sub>8</sub>-inch dowels for each bumper.

### 3.2 PROTECTION

- A. The Contractor shall protect curbs from damage until acceptance of the work. He shall exclude traffic from curbs for at least seven (7) days after placement and shall repair or replace broken or defective curbs as directed. He shall make provisions for pedestrians and vehicular traffic both during construction and during the seven (7) day traffic exclusion period using whatever barricades, warning signs, lanterns and lights may be necessary.

### 3.3 GUARANTEE

- A. The Contractor shall, for a period of one (1) year following acceptance of the work as indicated by the Owner's approval of the final payment application, guarantee that the curb and gutter will not chip, crack, or spall from natural causes. Should such defects occur, the Contractor shall return to the job site and replace the defective sections of curb and gutter at his own expense.

### 3.4 FIELD QUALITY CONTROL

- A. Refer to Section 01 40 00 – Quality Requirements
- B. Refer to Section 01 70 00 – Execution Requirements and Project Closeout

PART 4 - MUNICIPAL REQUIREMENTS

4.1 TAPER LENGTHS

- A. Where curb & gutter ends or transitions are being made for ramps and driveway cuts, the taper length shall be two feet, unless otherwise noted on the Plan Detail drawings.

END OF SECTION 32 13 13

SECTION 32 90 00 – LANDSCAPE RESTORATION

PART 1 - GENERAL

1.1 SUMMARY

A. Section Includes:

1. Final grade topsoil for finish landscaping.
2. Site contouring.
3. Finish ground cover.

1.2 SUBMITTALS

- A. Section 01 33 00 – Submittals: Submittal procedures
- B. Materials Source: Submit name of imported materials source.

1.3 QUALITY ASSURANCE

- A. Furnish each topsoil material from single source throughout the Work.

PART 2 - PRODUCTS

2.1 MATERIAL

- A. Topsoil

- 1. Topsoil shall conform to the requirements of section 31 05 00 – Soils, Aggregates and Geotextiles.

- B. Lime

- 1. Lime used for soil amendment shall be agricultural grade limestone ground sufficiently fine so that 80% passes a No. 8 sieve. Lime shall contain 80% calcium carbonate equivalent. Moisture shall not exceed 10%.

- C. Fertilizer

- 1. Fertilizer used in conjunction with seeding shall be dry, free-flowing granular fertilizer suitable for application by agricultural fertilizer spreaders or blower equipment, or non-volatile liquid commercial fertilizer, having an analysis of 20-10-10 (Nitrogen-Phosphoric Acid-Potash), or approved equal.

- D. Grass Seed for Lawns

- 1. Grass seed shall be delivered to the site in bags, tagged or labeled to show the percentage of purity and germination. The seed shall have been tested by a recognized seed testing laboratory within one year prior to the date of seeding and shall conform to the latest laws of the U.S. and the State of Wisconsin. Upon request the Contractor shall furnish to the Engineer copies of the test results. Permanent seed mixtures shall consist of the following percentages of various varieties of grass seed, each of which shall have the designated minimum percent purity and germination:

<b>Species</b>	<b>Purity Min. %</b>	<b>Germination Min. %</b>	<b>Mixture Proportions, Percent</b>
Kentucky Bluegrass	85	80	35
Creeping Red Fescue	97	85	20
Improved Hard Fescue	97	85	20

Species	Purity Min. %	Germination Min. %	Mixture Proportions, Percent
Improved Fine Perennial Ryegrass	96	85	25
*Pure Live Seed. These grasses shall contain no improved varieties			

2. The "Madison Parks" mix may be used as a permanent seed mixture.
3. As a companion seeding to the above seed mixture annual ryegrass of the same purity and germination standards shall be provided.

E. Grass Seed for Large Non-Lawn Areas

1. Grass seed shall be delivered to the site in bags, tagged or labeled to show the percentage of purity and germination. The seed shall have been tested by a recognized seed testing laboratory within one (1) year prior to the date of seeding and shall conform to the latest laws of the U.S. and the State of Wisconsin. Upon request the Contractor shall furnish to the Engineer copies of the test results. Permanent seed mixtures shall be seed mixture No. 10 for average soil conditions, including clay or loam soils and soils in moist conditions and seed mixture No. 20 for light, well drained, sandy or gravelly soils and for slopes and ditches, except on ditches between the edge of the shoulder and the bottom of the ditch where seed mixture No. 30 shall be used, all as specified in the Standard Specifications for Highway and Structure Construction published by the Wisconsin Department of Transportation.
2. A companion seeding to the above seed mixture of the same purity and germination standards shall be provided and applied as set forth in Part 3. Between May 15th and July 15th oats or Sudan grass shall be used as the companion seeding. From July 15th to September 15th use annual ryegrass as the companion seeding. After September 15th use winter wheat as the companion seeding.

F. Straw Mulch

1. Unless otherwise specified in the Special Conditions to the specifications, mulch shall be straw, free of grain, weed, seed and mold. Mulch materials shall not contain excessive moisture which might prevent feeding through a mulch blower machine.

G. Sod

1. Sod shall be fresh, predominantly bluegrass sod from an approved sod farm.

## PART 3 - EXECUTION

### 3.1 EXAMINATION

- A. Section 01 30 00 – Administrative Requirements: Verification of existing conditions before starting work.
- B. Verify substrate base has been contoured and compacted.
- C. Complete all seeding by September 15<sup>th</sup>.
- D. After preparation and prior to seeding notify Engineer so that the prepared surface may be inspected. Seeding or sodding shall not take place until the prepared surface is inspected by Engineer.

### 3.2 PREPARATION

- A. Protect landscaping and other features remaining as final Work.
- B. Perform a soil test to determine fertilizer needs and if lime is necessary.

### 3.3 SUBSTRATE PREPARATION

- A. Eliminate uneven areas and low spots.
- B. Remove weeds, debris, roots, branches, stones, and dust clumps in excess of ½-inch in size or lawn areas and in excess of 1-inch in size on non-lawn areas. Any topsoil containing gravel shall be removed and replaced with fresh topsoil. Remove contaminated subsoil.
- C. Scarify surface to depth of 3 inches where topsoil is scheduled. Scarify in areas where equipment used for hauling and spreading topsoil has compacted subsoil.

### 3.4 PLACING TOPSOIL

- A. Place topsoil in areas where seeding and sodding is required to nominal depth of at least 4 inches. Place topsoil during dry weather.
- B. Fine grade topsoil to eliminate rough or low areas. Maintain profiles and contour of subgrade.
- C. Remove roots, weeds, rocks, and foreign material while spreading.
- D. Manually spread topsoil close to plants and buildings to prevent damage.
- E. Lightly compact the placed topsoil.
- F. Remove surplus subsoil and topsoil from site.



- G. Leave stockpile area and site clean and raked, ready to receive landscaping.

### 3.5 FERTILIZER AND LIME APPLICATION ON LAWNS

- A. Fertilizer shall be applied with a hydroseeder, power-drawn drill or spreader, or blower equipment either separately from or concurrently with the grass seed. Fertilizing shall not be done with "broadcast"-type equipment during windy weather, and not at all when the ground is frozen or excessively moist. Fertilizer shall be applied at the following rates:

Nutrient	Per Acre	Per 1000 Square Feet
Nitrogen (N)	100 pounds	2.3 pounds
Phosphoric Acid (P <sub>2</sub> O <sub>5</sub> )	50 pounds	1.2 pounds
Potash (K <sub>2</sub> O)	50 pounds	1.2 pounds

- B. If the soil test indicates lime addition is necessary, apply at the rates indicated by the test.

### 3.6 FERTILIZER AND LIME APPLICATION ON NON-LAWN AREAS

- A. Fertilizer and lime shall be applied with a hydroseeder, power or spreader, or blower equipment either separately from or concurrently with the grass seed. Fertilizing shall not be done with "broadcast"-type equipment during windy weather, and not at all when the ground is frozen or excessively moist. Fertilizer and lime shall be applied at the rate specified by the soil test, or at 400 to 600 pounds per acre in lieu of a soil test.

### 3.7 LAWN SEEDING

- A. The Contractor shall apply the seed using a hydroseeder, a power-drawn drill or spreader, or approved blower equipment with an adjustable disseminating device capable of maintaining a constant measurement rate of material discharge that will insure an even distribution of seed and fertilizer.
- B. Permanent seed mixture shall be applied at the rate of 2 pounds/1000 square feet. A companion seeding of annual ryegrass, oats or winter wheat, depending upon the season, shall also be made at an application rate of 1 pound/1000 square feet.
- C. After the seeding is completed and prior to mulching the Contractor shall rake the surface with an inverted leaf rake to set the seed.

### 3.8 SEEDING LARGE NON-LAWN AREAS

- A. The Contractor shall apply the seed using a hydroseeder, a power-drawn drill or spreader, or approved blower equipment with an adjustable disseminating device

capable of maintaining a constant measurement rate of material discharge that will insure an even distribution of seed and fertilizer.

- B. Permanent seed mixture shall be applied at the rate of 1.5 pounds/1000 square feet. A companion seeding of annual ryegrass, oats or winter wheat, depending upon the season, shall also be made at an application rate of 0.8 pounds/1000 square feet.
- C. After the seeding is completed and prior to mulching the Contractor shall rake the surface with an inverted leaf rake to set the seed.

### 3.9 APPLICATION OF MULCH

- A. The Contractor shall furnish, haul and evenly apply straw mulch at a rate not less than 1½ tons per acre to a loose depth of one (1) to two (2) inches. Seventy to ninety percent of the surface shall be covered. The mulch spreading equipment shall utilize forced air to blow mulch material onto the seeded area, unless otherwise approved by the Engineer. Mulching shall not be conducted during very windy conditions.
- B. The mulch shall not be left in clumps and shall not be blown onto healthy grass, trees, shrubs, curbs, pavements, vehicles, etc. Any mulch which blows onto areas not intended to be mulched, such as those defined above, shall be immediately removed.
- C. Following application of the mulch, the Contractor shall anchor the straw mulch by cutting the mulch into the soil with notched edges of a weighted disc so that the mulch is partially embedded in the soil, or by other methods acceptable to the Engineer.
- D. Wood cellulose fiber, the use of which as mulch is permissible only on large non-lawn areas, shall be applied at a rate ¾ to 1-ton per acre. Wood cellulose fiber mulch need not be anchored.
- E. Hay or “marsh hay”, the use of which as mulch is permissible only on large non-lawn areas, shall be applied at the same rates and to the same criteria as straw mulch.

### 3.10 SODDING

- A. Sod shall be delivered to the site and installed on the same day. The Contractor shall place sod with edges in close contact and with joints staggered. Sod placement on slopes shall commence at the bottom of the slope, and the rows shall be laid perpendicular to the slope. The edge of the sod at the tops of slopes shall be turned slightly under, and a layer of soil shall be compacted over the edge to direct surface drainage over the edge onto the top of the sod. Sod placement in areas other than on slopes shall be made so that the top sod surface is flush with adjoining surfaces.
- B. On slopes steeper than 1:4, vertical to horizontal, the Contractor shall stake the sod with split cedar shingles, or other equally effective stakes, spaced from 18 to 36 inches apart along the longitudinal axis of the sod strip. These stakes shall be placed near the top edge of the sod strip and shall be driven flush with the sod.

- C. After the sod is placed, it shall be rolled or firmly tamped to press the sod onto the underlying soil. The Contractor shall thoroughly soak all sodded areas by sprinkling them with water at the end of the day in which the sod is laid.

### 3.11 WATERING OF SEED BEDS

- A. The sod shall be maintained in a moist growing condition. The Contractor shall soak the sod by sprinkling with water on the seven successive calendar days following completion of the seeding unless at least ¼-inch of rainfall has occurred on that day.

### 3.12 WATERING OF SOD

- A. The sod shall be maintained in a moist growing condition. The Contractor shall soak the sod by sprinkling with water on the seven successive calendar days following completion of the seeding unless at least ¼-inch of rainfall has occurred on that day.

### 3.13 TOLERANCES

- A. Top of Topsoil: Plus or minus ½-inch.

### 3.14 PROTECTION AND MAINTENANCE OF INSTALLED WORK

- A. Section 01 70 00 – Execution and Closeout Requirements: Requirements for protecting finished Work.
- B. Prohibit construction traffic over topsoil, both before and after grass restoration.
- C. Where paved drainage ways, curbs & gutters, culverts, storm sewers or other structures exist on the site the Contractor shall clean all soil, silt, mulch or debris and fully restore such drainage ways, devices and structures to their intended operating condition.
- D. After the restoration operation is completed, the Contractor shall provide and distribute to each property owner a sheet of instructions on how to care for the restored surface and how to ensure acceptable grass growth.

END OF SECTION 32 90 00



# AIA® Document A201® – 2017

## General Conditions of the Contract for Construction

**for the following PROJECT:**

*(Name and location or address)*

Evansville Maintenance Garage  
15 Old Hwy 92  
Evansville, WI 53562

**THE OWNER:**

*(Name, legal status and address)*

City of Evansville, WI  
31 S. Madison Street  
PO Box 529  
Evansville, WI 53536

**THE ARCHITECT:**

*(Name, legal status and address)*

Sketchworks Architecture, LLC  
7780 Elmwood Ave., Suite 208  
Middleton, WI 53562

**TABLE OF ARTICLES**

- 1      **GENERAL PROVISIONS**
- 2      **OWNER**
- 3      **CONTRACTOR**
- 4      **ARCHITECT**
- 5      **SUBCONTRACTORS**
- 6      **CONSTRUCTION BY OWNER OR BY SEPARATE CONTRACTORS**
- 7      **CHANGES IN THE WORK**
- 8      **TIME**
- 9      **PAYMENTS AND COMPLETION**
- 10     **PROTECTION OF PERSONS AND PROPERTY**
- 11     **INSURANCE AND BONDS**
- 12     **UNCOVERING AND CORRECTION OF WORK**
- 13     **MISCELLANEOUS PROVISIONS**

**ADDITIONS AND DELETIONS:**

The author of this document has added information needed for its completion. The author may also have revised the text of the original AIA standard form. An *Additions and Deletions Report* that notes added information as well as revisions to the standard form text is available from the author and should be reviewed. A vertical line in the left margin of this document indicates where the author has added necessary information and where the author has added to or deleted from the original AIA text.

This document has important legal consequences. Consultation with an attorney is encouraged with respect to its completion or modification.

For guidance in modifying this document to include supplementary conditions, see AIA Document A503™, Guide for Supplementary Conditions.

Init.

/

User Notes:

14 TERMINATION OR SUSPENSION OF THE CONTRACT

15 CLAIMS AND DISPUTES



Init.

/

## INDEX

(Topics and numbers in bold are Section headings.)

### Acceptance of Nonconforming Work

9.6.6, 9.9.3, **12.3**

Acceptance of Work

9.6.6, 9.8.2, 9.9.3, 9.10.1, 9.10.3, 12.3

### Access to Work

**3.16**, 6.2.1, 12.1

Accident Prevention

10

Acts and Omissions

3.2, 3.3.2, 3.12.8, 3.18, 4.2.3, 8.3.1, 9.5.1, 10.2.5,

10.2.8, 13.3.2, 14.1, 15.1.2, 15.2

Addenda

1.1.1

Additional Costs, Claims for

3.7.4, 3.7.5, 10.3.2, 15.1.5

### Additional Inspections and Testing

9.4.2, 9.8.3, 12.2.1, **13.4**

### Additional Time, Claims for

3.2.4, 3.7.4, 3.7.5, 3.10.2, 8.3.2, **15.1.6**

### Administration of the Contract

3.1.3, **4.2**, 9.4, 9.5

Advertisement or Invitation to Bid

1.1.1

Aesthetic Effect

4.2.13

### Allowances

**3.8**

### Applications for Payment

4.2.5, 7.3.9, 9.2, **9.3**, 9.4, 9.5.1, 9.5.4, 9.6.3, 9.7, 9.10

Approvals

2.1.1, 2.3.1, 2.5, 3.1.3, 3.10.2, 3.12.8, 3.12.9,

3.12.10.1, 4.2.7, 9.3.2, 13.4.1

### Arbitration

8.3.1, 15.3.2, **15.4**

## ARCHITECT

**4**

Architect, Definition of

### 4.1.1

Architect, Extent of Authority

2.5, 3.12.7, 4.1.2, 4.2, 5.2, 6.3, 7.1.2, 7.3.4, 7.4, 9.2,  
9.3.1, 9.4, 9.5, 9.6.3, 9.8, 9.10.1, 9.10.3, 12.1, 12.2.1,  
13.4.1, 13.4.2, 14.2.2, 14.2.4, 15.1.4, 15.2.1

Architect, Limitations of Authority and Responsibility

2.1.1, 3.12.4, 3.12.8, 3.12.10, 4.1.2, 4.2.1, 4.2.2, 4.2.3,  
4.2.6, 4.2.7, 4.2.10, 4.2.12, 4.2.13, 5.2.1, 7.4, 9.4.2,  
9.5.4, 9.6.4, 15.1.4, 15.2

Architect's Additional Services and Expenses

2.5, 12.2.1, 13.4.2, 13.4.3, 14.2.4

Architect's Administration of the Contract

3.1.3, 3.7.4, 15.2, 9.4.1, 9.5

Architect's Approvals

2.5, 3.1.3, 3.5, 3.10.2, 4.2.7

Architect's Authority to Reject Work

3.5, 4.2.6, 12.1.2, 12.2.1

Architect's Copyright

1.1.7, 1.5

Architect's Decisions

3.7.4, 4.2.6, 4.2.7, 4.2.11, 4.2.12, 4.2.13, 4.2.14, 6.3,  
7.3.4, 7.3.9, 8.1.3, 8.3.1, 9.2, 9.4.1, 9.5, 9.8.4, 9.9.1,  
13.4.2, 15.2

Architect's Inspections

3.7.4, 4.2.2, 4.2.9, 9.4.2, 9.8.3, 9.9.2, 9.10.1, 13.4

Architect's Instructions

3.2.4, 3.3.1, 4.2.6, 4.2.7, 13.4.2

Architect's Interpretations

4.2.11, 4.2.12

Architect's Project Representative

4.2.10

Architect's Relationship with Contractor

1.1.2, 1.5, 2.3.3, 3.1.3, 3.2.2, 3.2.3, 3.2.4, 3.3.1, 3.4.2,  
3.5, 3.7.4, 3.7.5, 3.9.2, 3.9.3, 3.10, 3.11, 3.12, 3.16,  
3.18, 4.1.2, 4.2, 5.2, 6.2.2, 7, 8.3.1, 9.2, 9.3, 9.4, 9.5,  
9.7, 9.8, 9.9, 10.2.6, 10.3, 11.3, 12, 13.3.2, 13.4, 15.2

Architect's Relationship with Subcontractors

1.1.2, 4.2.3, 4.2.4, 4.2.6, 9.6.3, 9.6.4, 11.3

Architect's Representations

9.4.2, 9.5.1, 9.10.1

Architect's Site Visits

3.7.4, 4.2.2, 4.2.9, 9.4.2, 9.5.1, 9.9.2, 9.10.1, 13.4

Asbestos

10.3.1

Attorneys' Fees

3.18.1, 9.6.8, 9.10.2, 10.3.3

Award of Separate Contracts

6.1.1, 6.1.2

### Award of Subcontracts and Other Contracts for Portions of the Work

**5.2**

### Basic Definitions

**1.1**

Bidding Requirements

1.1.1

Binding Dispute Resolution

8.3.1, 9.7, 11.5, 13.1, 15.1.2, 15.1.3, 15.2.1, 15.2.5,  
15.2.6.1, 15.3.1, 15.3.2, 15.3.3, 15.4.1

Bonds, Lien

7.3.4.4, 9.6.8, 9.10.2, 9.10.3

### Bonds, Performance, and Payment

7.3.4.4, 9.6.7, 9.10.3, **11.1.2**, 11.1.3, **11.5**

### Building Information Models Use and Reliance

**1.8**

Building Permit

3.7.1

### Capitalization

**1.3**

Certificate of Substantial Completion

9.8.3, 9.8.4, 9.8.5

Init.

/

## **Certificates for Payment**

4.2.1, 4.2.5, 4.2.9, 9.3.3, **9.4**, 9.5, 9.6.1, 9.6.6, 9.7, 9.10.1, 9.10.3, 14.1.1.3, 14.2.4, 15.1.4

Certificates of Inspection, Testing or Approval  
13.4.4

Certificates of Insurance  
9.10.2

## **Change Orders**

1.1.1, 3.4.2, 3.7.4, 3.8.2.3, 3.11, 3.12.8, 4.2.8, 5.2.3, 7.1.2, 7.1.3, **7.2**, 7.3.2, 7.3.7, 7.3.9, 7.3.10, 8.3.1, 9.3.1.1, 9.10.3, 10.3.2, 11.2, 11.5, 12.1.2

**Change Orders**, Definition of

### **7.2.1**

## **CHANGES IN THE WORK**

2.2.2, 3.11, 4.2.8, **7**, 7.2.1, 7.3.1, 7.4, 8.3.1, 9.3.1.1, 11.5

**Claims**, Definition of

### **15.1.1**

Claims, Notice of  
1.6.2, 15.1.3

## **CLAIMS AND DISPUTES**

3.2.4, 6.1.1, 6.3, 7.3.9, 9.3.3, 9.10.4, 10.3.3, **15**, 15.4  
Claims and Timely Assertion of Claims

15.4.1

### **Claims for Additional Cost**

3.2.4, 3.3.1, 3.7.4, 7.3.9, 9.5.2, 10.2.5, 10.3.2, **15.1.5**

### **Claims for Additional Time**

3.2.4, 3.3.1, 3.7.4, 6.1.1, 8.3.2, 9.5.2, 10.3.2, **15.1.6**

### **Concealed or Unknown Conditions, Claims for**

**3.7.4**  
Claims for Damages

3.2.4, 3.18, 8.3.3, 9.5.1, 9.6.7, 10.2.5, 10.3.3, 11.3, 11.3.2, 14.2.4, 15.1.7

Claims Subject to Arbitration  
15.4.1

## **Cleaning Up**

**3.15**, 6.3

Commencement of the Work, Conditions Relating to  
2.2.1, 3.2.2, 3.4.1, 3.7.1, 3.10.1, 3.12.6, 5.2.1, 5.2.3, 6.2.2, 8.1.2, 8.2.2, 8.3.1, 11.1, 11.2, **15.1.5**

### **Commencement of the Work**, Definition of

### **8.1.2**

## **Communications**

3.9.1, **4.2.4**

Completion, Conditions Relating to  
3.4.1, 3.11, 3.15, 4.2.2, 4.2.9, 8.2, 9.4.2, 9.8, 9.9.1, 9.10, 12.2, 14.1.2, 15.1.2

## **COMPLETION, PAYMENTS AND**

### **9**

Completion, Substantial  
3.10.1, 4.2.9, 8.1.1, 8.1.3, 8.2.3, 9.4.2, 9.8, 9.9.1, 9.10.3, 12.2, 15.1.2  
Compliance with Laws  
2.3.2, 3.2.3, 3.6, 3.7, 3.12.10, 3.13, 9.6.4, 10.2.2, 13.1, 13.3, 13.4.1, 13.4.2, 13.5, 14.1.1, 14.2.1.3, 15.2.8, 15.4.2, 15.4.3

## **Concealed or Unknown Conditions**

3.7.4, 4.2.8, 8.3.1, 10.3

## **Conditions of the Contract**

1.1.1, 6.1.1, 6.1.4

## **Consent, Written**

3.4.2, 3.14.2, 4.1.2, 9.8.5, 9.9.1, 9.10.2, 9.10.3, 13.2, 15.4.4.2

## **Consolidation or Joinder**

### **15.4.4**

## **CONSTRUCTION BY OWNER OR BY SEPARATE CONTRACTORS**

1.1.4, **6**

### **Construction Change Directive**, Definition of

### **7.3.1**

## **Construction Change Directives**

1.1.1, 3.4.2, 3.11, 3.12.8, 4.2.8, 7.1.1, 7.1.2, 7.1.3, **7.3**, 9.3.1.1

Construction Schedules, Contractor's

3.10, 3.11, 3.12.1, 3.12.2, 6.1.3, 15.1.6.2

## **Contingent Assignment of Subcontracts**

**5.4**, 14.2.2.2

## **Continuing Contract Performance**

### **15.1.4**

**Contract**, Definition of

### **1.1.2**

## **CONTRACT, TERMINATION OR SUSPENSION OF THE**

5.4.1.1, 5.4.2, 11.5, **14**

Contract Administration

3.1.3, 4, 9.4, 9.5

Contract Award and Execution, Conditions Relating to

3.7.1, 3.10, 5.2, 6.1

Contract Documents, Copies Furnished and Use of  
1.5.2, 2.3.6, 5.3

**Contract Documents**, Definition of

### **1.1.1**

## **Contract Sum**

2.2.2, 2.2.4, 3.7.4, 3.7.5, 3.8, 3.10.2, 5.2.3, 7.3, 7.4, **9.1**, 9.2, 9.4.2, 9.5.1.4, 9.6.7, 9.7, 10.3.2, 11.5, 12.1.2, 12.3, 14.2.4, 14.3.2, 15.1.4.2, **15.1.5**, **15.2.5**

### **Contract Sum**, Definition of

### **9.1**

Contract Time

1.1.4, 2.2.1, 2.2.2, 3.7.4, 3.7.5, 3.10.2, 5.2.3, 6.1.5, 7.2.1.3, 7.3.1, 7.3.5, 7.3.6, 7, 7.3.10, 7.4, 8.1.1, 8.2.1, 8.2.3, 8.3.1, 9.5.1, 9.7, 10.3.2, 12.1.1, 12.1.2, 14.3.2, 15.1.4.2, 15.1.6.1, 15.2.5

**Contract Time**, Definition of

### **8.1.1**

## **CONTRACTOR**

### **3**

Contractor, Definition of

### **3.1**, **6.1.2**

## **Contractor's Construction and Submittal Schedules**

**3.10**, 3.12.1, 3.12.2, 4.2.3, 6.1.3, 15.1.6.2

### **3.10**, 3.12.1, 3.12.2, 4.2.3, 6.1.3, 15.1.6.2

## **Contractor's Construction and Submittal Schedules**

**3.10**, 3.12.1, 3.12.2, 4.2.3, 6.1.3, 15.1.6.2

Init.

/

Contractor's Employees  
2.2.4, 3.3.2, 3.4.3, 3.8.1, 3.9, 3.18.2, 4.2.3, 4.2.6, 10.2,  
10.3, 11.3, 14.1, 14.2.1.1

### **Contractor's Liability Insurance**

#### **11.1**

Contractor's Relationship with Separate Contractors  
and Owner's Forces

3.12.5, 3.14.2, 4.2.4, 6, 11.3, 12.2.4

Contractor's Relationship with Subcontractors

1.2.2, 2.2.4, 3.3.2, 3.18.1, 3.18.2, 4.2.4, 5, 9.6.2, 9.6.7,  
9.10.2, 11.2, 11.3, 11.4

Contractor's Relationship with the Architect

1.1.2, 1.5, 2.3.3, 3.1.3, 3.2.2, 3.2.3, 3.2.4, 3.3.1, 3.4.2,  
3.5.1, 3.7.4, 3.10, 3.11, 3.12, 3.16, 3.18, 4.2, 5.2, 6.2.2,  
7, 8.3.1, 9.2, 9.3, 9.4, 9.5, 9.7, 9.8, 9.9, 10.2.6, 10.3,  
11.3, 12, 13.4, 15.1.3, 15.2.1

Contractor's Representations

3.2.1, 3.2.2, 3.5, 3.12.6, 6.2.2, 8.2.1, 9.3.3, 9.8.2

Contractor's Responsibility for Those Performing the  
Work

3.3.2, 3.18, 5.3, 6.1.3, 6.2, 9.5.1, 10.2.8

Contractor's Review of Contract Documents

3.2

Contractor's Right to Stop the Work

2.2.2, 9.7

Contractor's Right to Terminate the Contract

14.1

Contractor's Submittals

3.10, 3.11, 3.12, 4.2.7, 5.2.1, 5.2.3, 9.2, 9.3, 9.8.2,  
9.8.3, 9.9.1, 9.10.2, 9.10.3

Contractor's Superintendent

3.9, 10.2.6

Contractor's Supervision and Construction

Procedures

1.2.2, 3.3, 3.4, 3.12.10, 4.2.2, 4.2.7, 6.1.3, 6.2.4, 7.1.3,  
7.3.4, 7.3.6, 8.2, 10, 12, 14, 15.1.4

Coordination and Correlation

1.2, 3.2.1, 3.3.1, 3.10, 3.12.6, 6.1.3, 6.2.1

Copies Furnished of Drawings and Specifications

1.5, 2.3.6, 3.11

Copyrights

1.5, **3.17**

Correction of Work

2.5, 3.7.3, 9.4.2, 9.8.2, 9.8.3, 9.9.1, 12.1.2, **12.2**, 12.3,  
15.1.3.1, 15.1.3.2, 15.2.1

**Correlation and Intent of the Contract Documents**

**1.2**

**Cost**, Definition of

**7.3.4**

Costs

2.5, 3.2.4, 3.7.3, 3.8.2, 3.15.2, 5.4.2, 6.1.1, 6.2.3,  
7.3.3.3, 7.3.4, 7.3.8, 7.3.9, 9.10.2, 10.3.2, 10.3.6, 11.2,  
12.1.2, 12.2.1, 12.2.4, 13.4, 14

**Cutting and Patching**

**3.14**, 6.2.5

Damage to Construction of Owner or Separate  
Contractors

3.14.2, 6.2.4, 10.2.1.2, 10.2.5, 10.4, 12.2.4

Damage to the Work

3.14.2, 9.9.1, 10.2.1.2, 10.2.5, 10.4, 12.2.4

Damages, Claims for

3.2.4, 3.18, 6.1.1, 8.3.3, 9.5.1, 9.6.7, 10.3.3, 11.3.2,  
11.3, 14.2.4, 15.1.7

Damages for Delay

6.2.3, 8.3.3, 9.5.1.6, 9.7, 10.3.2, 14.3.2

**Date of Commencement of the Work**, Definition of

**8.1.2**

**Date of Substantial Completion**, Definition of

**8.1.3**

**Day**, Definition of

**8.1.4**

Decisions of the Architect

3.7.4, 4.2.6, 4.2.7, 4.2.11, 4.2.12, 4.2.13, 6.3, 7.3.4,  
7.3.9, 8.1.3, 8.3.1, 9.2, 9.4, 9.5.1, 9.8.4, 9.9.1, 13.4.2,  
14.2.2, 14.2.4, 15.1, 15.2

**Decisions to Withhold Certification**

9.4.1, **9.5**, 9.7, 14.1.1.3

Defective or Nonconforming Work, Acceptance,  
Rejection and Correction of

2.5, 3.5, 4.2.6, 6.2.3, 9.5.1, 9.5.3, 9.6.6, 9.8.2, 9.9.3,  
9.10.4, 12.2.1

Definitions

1.1, 2.1.1, 3.1.1, 3.5, 3.12.1, 3.12.2, 3.12.3, 4.1.1, 5.1,  
6.1.2, 7.2.1, 7.3.1, 8.1, 9.1, 9.8.1, 15.1.1

**Delays and Extensions of Time**

**3.2**, **3.7.4**, 5.2.3, 7.2.1, 7.3.1, **7.4**, **8.3**, 9.5.1, **9.7**,  
10.3.2, **10.4**, 14.3.2, **15.1.6**, 15.2.5

**Digital Data Use and Transmission**

**1.7**

Disputes

6.3, 7.3.9, 15.1, 15.2

**Documents and Samples at the Site**

**3.11**

**Drawings**, Definition of

**1.1.5**

Drawings and Specifications, Use and Ownership of

3.11

Effective Date of Insurance

8.2.2

**Emergencies**

**10.4**, 14.1.1.2, **15.1.5**

Employees, Contractor's

3.3.2, 3.4.3, 3.8.1, 3.9, 3.18.2, 4.2.3, 4.2.6, 10.2,  
10.3.3, 11.3, 14.1, 14.2.1.1

Equipment, Labor, or Materials

1.1.3, 1.1.6, 3.4, 3.5, 3.8.2, 3.8.3, 3.12, 3.13, 3.15.1,  
4.2.6, 4.2.7, 5.2.1, 6.2.1, 7.3.4, 9.3.2, 9.3.3, 9.5.1.3,  
9.10.2, 10.2.1, 10.2.4, 14.2.1.1, 14.2.1.2

Execution and Progress of the Work

1.1.3, 1.2.1, 1.2.2, 2.3.4, 2.3.6, 3.1, 3.3.1, 3.4.1, 3.7.1,  
3.10.1, 3.12, 3.14, 4.2, 6.2.2, 7.1.3, 7.3.6, 8.2, 9.5.1,  
9.9.1, 10.2, 10.3, 12.1, 12.2, 14.2, 14.3.1, 15.1.4

Init.

/



Extensions of Time  
3.2.4, 3.7.4, 5.2.3, 7.2.1, 7.3, 7.4, 9.5.1, 9.7, 10.3.2,  
10.4, 14.3, 15.1.6, **15.2.5**

#### **Failure of Payment**

9.5.1.3, **9.7**, 9.10.2, 13.5, 14.1.1.3, 14.2.1.2

#### **Faulty Work**

(See Defective or Nonconforming Work)

#### **Final Completion and Final Payment**

4.2.1, 4.2.9, 9.8.2, **9.10**, 12.3, 14.2.4, 14.4.3

#### **Financial Arrangements, Owner's**

2.2.1, 13.2.2, 14.1.1.4

### **GENERAL PROVISIONS**

#### **1**

#### **Governing Law**

##### **13.1**

Guarantees (See Warranty)

#### **Hazardous Materials and Substances**

10.2.4, **10.3**

Identification of Subcontractors and Suppliers

5.2.1

#### **Indemnification**

3.17, **3.18**, 9.6.8, 9.10.2, 10.3.3, 11.3

#### **Information and Services Required of the Owner**

2.1.2, **2.2**, 2.3, 3.2.2, 3.12.10.1, 6.1.3, 6.1.4, 6.2.5,

9.6.1, 9.9.2, 9.10.3, 10.3.3, 11.2, 13.4.1, 13.4.2,

14.1.1.4, 14.1.4, 15.1.4

#### **Initial Decision**

##### **15.2**

#### **Initial Decision Maker, Definition of**

1.1.8

Initial Decision Maker, Decisions

14.2.4, 15.1.4.2, 15.2.1, 15.2.2, 15.2.3, 15.2.4, 15.2.5

Initial Decision Maker, Extent of Authority

14.2.4, 15.1.4.2, 15.2.1, 15.2.2, 15.2.3, 15.2.4, 15.2.5

#### **Injury or Damage to Person or Property**

**10.2.8**, 10.4

#### **Inspections**

3.1.3, 3.3.3, 3.7.1, 4.2.2, 4.2.6, 4.2.9, 9.4.2, 9.8.3,

9.9.2, 9.10.1, 12.2.1, 13.4

#### **Instructions to Bidders**

1.1.1

Instructions to the Contractor

3.2.4, 3.3.1, 3.8.1, 5.2.1, 7, 8.2.2, 12, 13.4.2

#### **Instruments of Service, Definition of**

##### **1.1.7**

#### **Insurance**

6.1.1, 7.3.4, 8.2.2, 9.3.2, 9.8.4, 9.9.1, 9.10.2, 10.2.5, **11**

Insurance, Notice of Cancellation or Expiration

11.1.4, 11.2.3

#### **Insurance, Contractor's Liability**

##### **11.1**

Insurance, Effective Date of

8.2.2, 14.4.2

#### **Insurance, Owner's Liability**

##### **11.2**

#### **Insurance, Property**

**10.2.5**, 11.2, 11.4, 11.5

#### **Insurance, Stored Materials**

9.3.2

### **INSURANCE AND BONDS**

#### **11**

Insurance Companies, Consent to Partial Occupancy

9.9.1

Insured loss, Adjustment and Settlement of

11.5

Intent of the Contract Documents

1.2.1, 4.2.7, 4.2.12, 4.2.13

#### **Interest**

##### **13.5**

#### **Interpretation**

1.1.8, 1.2.3, **1.4**, 4.1.1, 5.1, 6.1.2, 15.1.1

Interpretations, Written

4.2.11, 4.2.12

Judgment on Final Award

15.4.2

#### **Labor and Materials, Equipment**

1.1.3, 1.1.6, **3.4**, 3.5, 3.8.2, 3.8.3, 3.12, 3.13, 3.15.1,

5.2.1, 6.2.1, 7.3.4, 9.3.2, 9.3.3, 9.5.1.3, 9.10.2, 10.2.1,

10.2.4, 14.2.1.1, 14.2.1.2

Labor Disputes

8.3.1

Laws and Regulations

1.5, 2.3.2, 3.2.3, 3.2.4, 3.6, 3.7, 3.12.10, 3.13, 9.6.4,

9.9.1, 10.2.2, 13.1, 13.3.1, 13.4.2, 13.5, 14, 15.2.8,

15.4

Liens

2.1.2, 9.3.1, 9.3.3, 9.6.8, 9.10.2, 9.10.4, 15.2.8

Limitations, Statutes of

12.2.5, 15.1.2, 15.4.1.1

Limitations of Liability

3.2.2, 3.5, 3.12.10, 3.12.10.1, 3.17, 3.18.1, 4.2.6,

4.2.7, 6.2.2, 9.4.2, 9.6.4, 9.6.7, 9.6.8, 10.2.5, 10.3.3,

11.3, 12.2.5, 13.3.1

Limitations of Time

2.1.2, 2.2, 2.5, 3.2.2, 3.10, 3.11, 3.12.5, 3.15.1, 4.2.7,

5.2, 5.3, 5.4.1, 6.2.4, 7.3, 7.4, 8.2, 9.2, 9.3.1, 9.3.3,

9.4.1, 9.5, 9.6, 9.7, 9.8, 9.9, 9.10, 12.2, 13.4, 14, 15,

15.1.2, 15.1.3, 15.1.5

#### **Materials, Hazardous**

**10.2.4**, **10.3**

Materials, Labor, Equipment and

1.1.3, 1.1.6, 3.4.1, 3.5, 3.8.2, 3.8.3, 3.12, 3.13, 3.15.1,

5.2.1, 6.2.1, 7.3.4, 9.3.2, 9.3.3, 9.5.1.3, 9.10.2,

10.2.1.2, 10.2.4, 14.2.1.1, 14.2.1.2

Means, Methods, Techniques, Sequences and

Procedures of Construction

3.3.1, 3.12.10, 4.2.2, 4.2.7, 9.4.2

Mechanic's Lien

2.1.2, 9.3.1, 9.3.3, 9.6.8, 9.10.2, 9.10.4, 15.2.8

#### **Mediation**

8.3.1, 15.1.3.2, 15.2.1, 15.2.5, 15.2.6, **15.3**, 15.4.1,

15.4.1.1

#### **Minor Changes in the Work**

1.1.1, 3.4.2, 3.12.8, 4.2.8, 7.1, **7.4**

Init.

/

## MISCELLANEOUS PROVISIONS

### 13

#### Modifications, Definition of

##### 1.1.1

#### Modifications to the Contract

1.1.1, 1.1.2, 2.5, 3.11, 4.1.2, 4.2.1, 5.2.3, 7, 8.3.1, 9.7, 10.3.2

#### Mutual Responsibility

### 6.2

#### Nonconforming Work, Acceptance of

9.6.6, 9.9.3, **12.3**

Nonconforming Work, Rejection and Correction of  
2.4, 2.5, 3.5, 4.2.6, 6.2.4, 9.5.1, 9.8.2, 9.9.3, 9.10.4, 12.2

#### Notice

**1.6**, 1.6.1, 1.6.2, 2.1.2, 2.2.2., 2.2.3, 2.2.4, 2.5, 3.2.4, 3.3.1, 3.7.4, 3.7.5, 3.9.2, 3.12.9, 3.12.10, 5.2.1, 7.4, 8.2.2, 9.6.8, 9.7, 9.10.1, 10.2.8, 10.3.2, 11.5, 12.2.2.1, 13.4.1, 13.4.2, 14.1, 14.2.2, 14.4.2, 15.1.3, 15.1.5, 15.1.6, 15.4.1

#### Notice of Cancellation or Expiration of Insurance

11.1.4, 11.2.3

#### Notice of Claims

1.6.2, 2.1.2, 3.7.4, 9.6.8, 10.2.8, **15.1.3**, 15.1.5, 15.1.6, 15.2.8, 15.3.2, 15.4.1

#### Notice of Testing and Inspections

13.4.1, 13.4.2

#### Observations, Contractor's

3.2, 3.7.4

#### Occupancy

2.3.1, 9.6.6, 9.8

#### Orders, Written

1.1.1, 2.4, 3.9.2, 7, 8.2.2, 11.5, 12.1, 12.2.2.1, 13.4.2, 14.3.1

## OWNER

### 2

#### Owner, Definition of

##### 2.1.1

#### Owner, Evidence of Financial Arrangements

**2.2**, 13.2.2, 14.1.1.4

#### Owner, Information and Services Required of the

2.1.2, **2.2**, 2.3, 3.2.2, 3.12.10, 6.1.3, 6.1.4, 6.2.5, 9.3.2, 9.6.1, 9.6.4, 9.9.2, 9.10.3, 10.3.3, 11.2, 13.4.1, 13.4.2, 14.1.1.4, 14.1.4, 15.1.4

#### Owner's Authority

1.5, 2.1.1, 2.3.32.4, 2.5, 3.4.2, 3.8.1, 3.12.10, 3.14.2, 4.1.2, 4.2.4, 4.2.9, 5.2.1, 5.2.4, 5.4.1, 6.1, 6.3, 7.2.1, 7.3.1, 8.2.2, 8.3.1, 9.3.2, 9.5.1, 9.6.4, 9.9.1, 9.10.2, 10.3.2, 11.4, 11.5, 12.2.2, 12.3, 13.2.2, 14.3, 14.4, 15.2.7

#### Owner's Insurance

### 11.2

#### Owner's Relationship with Subcontractors

1.1.2, 5.2, 5.3, 5.4, 9.6.4, 9.10.2, 14.2.2

#### Owner's Right to Carry Out the Work

**2.5**, 14.2.2

#### Owner's Right to Clean Up

### 6.3

#### Owner's Right to Perform Construction and to Award Separate Contracts

### 6.1

#### Owner's Right to Stop the Work

### 2.4

#### Owner's Right to Suspend the Work

14.3

#### Owner's Right to Terminate the Contract

14.2, 14.4

#### Ownership and Use of Drawings, Specifications and Other Instruments of Service

1.1.1, 1.1.6, 1.1.7, **1.5**, 2.3.6, 3.2.2, 3.11, 3.17, 4.2.12, 5.3

#### Partial Occupancy or Use

9.6.6, **9.9**

#### Patching, Cutting and

**3.14**, 6.2.5

#### Patents

3.17

#### Payment, Applications for

4.2.5, 7.3.9, 9.2, **9.3**, 9.4, 9.5, 9.6.3, 9.7, 9.8.5, 9.10.1, 14.2.3, 14.2.4, 14.4.3

#### Payment, Certificates for

4.2.5, 4.2.9, 9.3.3, **9.4**, 9.5, 9.6.1, 9.6.6, 9.7, 9.10.1, 9.10.3, 14.1.1.3, 14.2.4

#### Payment, Failure of

9.5.1.3, **9.7**, 9.10.2, 13.5, 14.1.1.3, 14.2.1.2

#### Payment, Final

4.2.1, 4.2.9, **9.10**, 12.3, 14.2.4, 14.4.3

#### Payment Bond, Performance Bond and

7.3.4.4, 9.6.7, 9.10.3, **11.1.2**

#### Payments, Progress

9.3, **9.6**, 9.8.5, 9.10.3, 14.2.3, 15.1.4

## PAYMENTS AND COMPLETION

### 9

#### Payments to Subcontractors

5.4.2, 9.5.1.3, 9.6.2, 9.6.3, 9.6.4, 9.6.7, 14.2.1.2

#### PCB

10.3.1

#### Performance Bond and Payment Bond

7.3.4.4, 9.6.7, 9.10.3, **11.1.2**

#### Permits, Fees, Notices and Compliance with Laws

2.3.1, **3.7**, 3.13, 7.3.4.4, 10.2.2

## PERSONS AND PROPERTY, PROTECTION OF

### 10

#### Polychlorinated Biphenyl

10.3.1

#### Product Data, Definition of

### 3.12.2

#### Product Data and Samples, Shop Drawings

3.11, **3.12**, 4.2.7

#### Progress and Completion

4.2.2, **8.2**, 9.8, 9.9.1, 14.1.4, 15.1.4

#### Progress Payments

9.3, **9.6**, 9.8.5, 9.10.3, 14.2.3, 15.1.4

Init.

/

**Project, Definition of**  
**1.1.4**  
Project Representatives  
4.2.10  
**Property Insurance**  
10.2.5, **11.2**  
**Proposal Requirements**  
1.1.1  
**PROTECTION OF PERSONS AND PROPERTY**  
**10**  
Regulations and Laws  
1.5, 2.3.2, 3.2.3, 3.6, 3.7, 3.12.10, 3.13, 9.6.4, 9.9.1,  
10.2.2, 13.1, 13.3, 13.4.1, 13.4.2, 13.5, 14, 15.2.8, 15.4  
Rejection of Work  
4.2.6, 12.2.1  
Releases and Waivers of Liens  
9.3.1, 9.10.2  
Representations  
3.2.1, 3.5, 3.12.6, 8.2.1, 9.3.3, 9.4.2, 9.5.1, 9.10.1  
Representatives  
2.1.1, 3.1.1, 3.9, 4.1.1, 4.2.10, 13.2.1  
Responsibility for Those Performing the Work  
3.3.2, 3.18, 4.2.2, 4.2.3, 5.3, 6.1.3, 6.2, 6.3, 9.5.1, 10  
Retainage  
9.3.1, 9.6.2, 9.8.5, 9.9.1, 9.10.2, 9.10.3  
**Review of Contract Documents and Field**  
**Conditions by Contractor**  
**3.2**, 3.12.7, 6.1.3  
Review of Contractor's Submittals by Owner and  
Architect  
3.10.1, 3.10.2, 3.11, 3.12, 4.2, 5.2, 6.1.3, 9.2, 9.8.2  
Review of Shop Drawings, Product Data and Samples  
by Contractor  
3.12  
**Rights and Remedies**  
1.1.2, 2.4, 2.5, 3.5, 3.7.4, 3.15.2, 4.2.6, 5.3, 5.4, 6.1,  
6.3, 7.3.1, 8.3, 9.5.1, 9.7, 10.2.5, 10.3, 12.2.1, 12.2.2,  
12.2.4, **13.3**, 14, 15.4  
**Royalties, Patents and Copyrights**  
**3.17**  
Rules and Notices for Arbitration  
15.4.1  
**Safety of Persons and Property**  
**10.2**, 10.4  
**Safety Precautions and Programs**  
3.3.1, 4.2.2, 4.2.7, 5.3, **10.1**, 10.2, 10.4  
**Samples, Definition of**  
**3.12.3**  
**Samples, Shop Drawings, Product Data and**  
3.11, **3.12**, 4.2.7  
**Samples at the Site, Documents and**  
**3.11**  
**Schedule of Values**  
**9.2**, 9.3.1  
Schedules, Construction  
3.10, 3.12.1, 3.12.2, 6.1.3, 15.1.6.2

Separate Contracts and Contractors  
1.1.4, 3.12.5, 3.14.2, 4.2.4, 4.2.7, 6, 8.3.1, 12.1.2  
**Separate Contractors, Definition of**  
**6.1.1**  
**Shop Drawings, Definition of**  
**3.12.1**  
**Shop Drawings, Product Data and Samples**  
3.11, **3.12**, 4.2.7  
**Site, Use of**  
**3.13**, 6.1.1, 6.2.1  
Site Inspections  
3.2.2, 3.3.3, 3.7.1, 3.7.4, 4.2, 9.9.2, 9.4.2, 9.10.1, 13.4  
Site Visits, Architect's  
3.7.4, 4.2.2, 4.2.9, 9.4.2, 9.5.1, 9.9.2, 9.10.1, 13.4  
Special Inspections and Testing  
4.2.6, 12.2.1, 13.4  
**Specifications, Definition of**  
**1.1.6**  
**Specifications**  
1.1.1, **1.1.6**, 1.2.2, 1.5, 3.12.10, 3.17, 4.2.14  
Statute of Limitations  
15.1.2, 15.4.1.1  
Stopping the Work  
2.2.2, 2.4, 9.7, 10.3, 14.1  
Stored Materials  
6.2.1, 9.3.2, 10.2.1.2, 10.2.4  
**Subcontractor, Definition of**  
**5.1.1**  
**SUBCONTRACTORS**  
**5**  
Subcontractors, Work by  
1.2.2, 3.3.2, 3.12.1, 3.18, 4.2.3, 5.2.3, 5.3, 5.4, 9.3.1.2,  
9.6.7  
**Subcontractual Relations**  
**5.3**, 5.4, 9.3.1.2, 9.6, 9.10, 10.2.1, 14.1, 14.2.1  
Submittals  
3.10, 3.11, 3.12, 4.2.7, 5.2.1, 5.2.3, 7.3.4, 9.2, 9.3, 9.8,  
9.9.1, 9.10.2, 9.10.3  
Submittal Schedule  
3.10.2, 3.12.5, 4.2.7  
**Subrogation, Waivers of**  
6.1.1, **11.3**  
**Substances, Hazardous**  
**10.3**  
**Substantial Completion**  
4.2.9, 8.1.1, 8.1.3, 8.2.3, 9.4.2, **9.8**, 9.9.1, 9.10.3, 12.2,  
15.1.2  
**Substantial Completion, Definition of**  
**9.8.1**  
Substitution of Subcontractors  
5.2.3, 5.2.4  
Substitution of Architect  
2.3.3  
Substitutions of Materials  
3.4.2, 3.5, 7.3.8  
**Sub-subcontractor, Definition of**  
**5.1.2**

Init.

/

Subsurface Conditions  
3.7.4

**Successors and Assigns**  
**13.2**

**Superintendent**  
**3.9, 10.2.6**

**Supervision and Construction Procedures**  
1.2.2, **3.3**, 3.4, 3.12.10, 4.2.2, 4.2.7, 6.1.3, 6.2.4, 7.1.3,  
7.3.4, 8.2, 8.3.1, 9.4.2, 10, 12, 14, 15.1.4

Suppliers  
1.5, 3.12.1, 4.2.4, 4.2.6, 5.2.1, 9.3, 9.4.2, 9.5.4, 9.6,  
9.10.5, 14.2.1

Surety  
5.4.1.2, 9.6.8, 9.8.5, 9.10.2, 9.10.3, 11.1.2, 14.2.2,  
15.2.7

Surety, Consent of  
9.8.5, 9.10.2, 9.10.3

Surveys  
1.1.7, 2.3.4

**Suspension by the Owner for Convenience**  
**14.3**

Suspension of the Work  
3.7.5, 5.4.2, 14.3  
Suspension or Termination of the Contract  
5.4.1.1, 14

**Taxes**  
3.6, 3.8.2.1, 7.3.4.4

**Termination by the Contractor**  
**14.1, 15.1.7**

**Termination by the Owner for Cause**  
5.4.1.1, **14.2**, 15.1.7

**Termination by the Owner for Convenience**  
**14.4**

Termination of the Architect  
2.3.3  
Termination of the Contractor Employment  
14.2.2

**TERMINATION OR SUSPENSION OF THE  
CONTRACT**

**14**

**Tests and Inspections**  
3.1.3, 3.3.3, 3.7.1, 4.2.2, 4.2.6, 4.2.9, 9.4.2, 9.8.3,  
9.9.2, 9.10.1, 10.3.2, 12.2.1, **13.4**

**TIME**  
**8**

**Time, Delays and Extensions of**  
3.2.4, 3.7.4, 5.2.3, 7.2.1, 7.3.1, 7.4, **8.3**, 9.5.1, 9.7,  
10.3.2, 10.4, 14.3.2, 15.1.6, 15.2.5

**Time Limits**

2.1.2, 2.2, 2.5, 3.2.2, 3.10, 3.11, 3.12.5, 3.15.1, 4.2,  
5.2, 5.3, 5.4, 6.2.4, 7.3, 7.4, 8.2, 9.2, 9.3.1, 9.3.3, 9.4.1,  
9.5, 9.6, 9.7, 9.8, 9.9, 9.10, 12.2, 13.4, 14, 15.1.2,  
15.1.3, 15.4

**Time Limits on Claims**  
3.7.4, 10.2.8, 15.1.2, 15.1.3

Title to Work  
9.3.2, 9.3.3

**UNCOVERING AND CORRECTION OF WORK**  
**12**

**Uncovering of Work**  
**12.1**

Unforeseen Conditions, Concealed or Unknown  
3.7.4, 8.3.1, 10.3

Unit Prices  
7.3.3.2, 9.1.2

Use of Documents  
1.1.1, 1.5, 2.3.6, 3.12.6, 5.3

**Use of Site**  
**3.13, 6.1.1, 6.2.1**

**Values, Schedule of**  
**9.2, 9.3.1**

Waiver of Claims by the Architect  
13.3.2

Waiver of Claims by the Contractor  
9.10.5, 13.3.2, **15.1.7**

Waiver of Claims by the Owner  
9.9.3, 9.10.3, 9.10.4, 12.2.2.1, 13.3.2, 14.2.4, **15.1.7**

Waiver of Consequential Damages  
14.2.4, 15.1.7

Waiver of Liens  
9.3, 9.10.2, 9.10.4

**Waivers of Subrogation**  
6.1.1, **11.3**

**Warranty**  
**3.5, 4.2.9, 9.3.3, 9.8.4, 9.9.1, 9.10.2, 9.10.4, 12.2.2,**  
15.1.2

Weather Delays  
8.3, 15.1.6.2

**Work, Definition of**  
**1.1.3**

Written Consent  
1.5.2, 3.4.2, 3.7.4, 3.12.8, 3.14.2, 4.1.2, 9.3.2, 9.10.3,  
13.2, 13.3.2, 15.4.4.2

Written Interpretations  
4.2.11, 4.2.12

Written Orders  
1.1.1, 2.4, 3.9, 7, 8.2.2, 12.1, 12.2, 13.4.2, 14.3.1

## **ARTICLE 1 GENERAL PROVISIONS**

### **§ 1.1 Basic Definitions**

#### **§ 1.1.1 The Contract Documents**

The Contract Documents are enumerated in the Agreement between the Owner and Contractor (hereinafter the Agreement) and consist of the Agreement, Conditions of the Contract (General, Supplementary and other Conditions), Drawings, Specifications, Addenda issued prior to execution of the Contract, other documents listed in the Agreement, and Modifications issued after execution of the Contract. A Modification is (1) a written amendment to the Contract signed by both parties, (2) a Change Order, (3) a Construction Change Directive, or (4) a written order for a minor change in the Work issued by the Architect. Unless specifically enumerated in the Agreement, the Contract Documents do not include the advertisement or invitation to bid, Instructions to Bidders, sample forms, other information furnished by the Owner in anticipation of receiving bids or proposals, the Contractor's bid or proposal, or portions of Addenda relating to bidding or proposal requirements.

#### **§ 1.1.2 The Contract**

The Contract Documents form the Contract for Construction. The Contract represents the entire and integrated agreement between the parties hereto and supersedes prior negotiations, representations, or agreements, either written or oral. The Contract may be amended or modified only by a Modification. The Contract Documents shall not be construed to create a contractual relationship of any kind (1) between the Contractor and the Architect or the Architect's consultants, (2) between the Owner and a Subcontractor or a Sub-subcontractor, (3) between the Owner and the Architect or the Architect's consultants, or (4) between any persons or entities other than the Owner and the Contractor. The Architect shall, however, be entitled to performance and enforcement of obligations under the Contract intended to facilitate performance of the Architect's duties.

#### **§ 1.1.3 The Work**

The term "Work" means the construction and services required by the Contract Documents, whether completed or partially completed, and includes all other labor, materials, equipment, and services provided or to be provided by the Contractor to fulfill the Contractor's obligations. The Work may constitute the whole or a part of the Project.

#### **§ 1.1.4 The Project**

The Project is the total construction of which the Work performed under the Contract Documents may be the whole or a part and which may include construction by the Owner and by Separate Contractors.

#### **§ 1.1.5 The Drawings**

The Drawings are the graphic and pictorial portions of the Contract Documents showing the design, location and dimensions of the Work, generally including plans, elevations, sections, details, schedules, and diagrams.

#### **§ 1.1.6 The Specifications**

The Specifications are that portion of the Contract Documents consisting of the written requirements for materials, equipment, systems, standards and workmanship for the Work, and performance of related services.

#### **§ 1.1.7 Instruments of Service**

Instruments of Service are representations, in any medium of expression now known or later developed, of the tangible and intangible creative work performed by the Architect and the Architect's consultants under their respective professional services agreements. Instruments of Service may include, without limitation, studies, surveys, models, sketches, drawings, specifications, and other similar materials.

#### **§ 1.1.8 Initial Decision Maker**

The Initial Decision Maker is the person identified in the Agreement to render initial decisions on Claims in accordance with Section 15.2. The Initial Decision Maker shall not show partiality to the Owner or Contractor and shall not be liable for results of interpretations or decisions rendered in good faith.

### **§ 1.2 Correlation and Intent of the Contract Documents**

**§ 1.2.1** The intent of the Contract Documents is to include all items necessary for the proper execution and completion of the Work by the Contractor. The Contract Documents are complementary, and what is required by one shall be as binding as if required by all; performance by the Contractor shall be required only to the extent consistent with the Contract Documents and reasonably inferable from them as being necessary to produce the indicated results.



§ 1.2.1.1 The invalidity of any provision of the Contract Documents shall not invalidate the Contract or its remaining provisions. If it is determined that any provision of the Contract Documents violates any law, or is otherwise invalid or unenforceable, then that provision shall be revised to the extent necessary to make that provision legal and enforceable. In such case the Contract Documents shall be construed, to the fullest extent permitted by law, to give effect to the parties' intentions and purposes in executing the Contract.

§ 1.2.2 Organization of the Specifications into divisions, sections and articles, and arrangement of Drawings shall not control the Contractor in dividing the Work among Subcontractors or in establishing the extent of Work to be performed by any trade.

§ 1.2.3 Unless otherwise stated in the Contract Documents, words that have well-known technical or construction industry meanings are used in the Contract Documents in accordance with such recognized meanings.

### § 1.3 Capitalization

Terms capitalized in these General Conditions include those that are (1) specifically defined, (2) the titles of numbered articles, or (3) the titles of other documents published by the American Institute of Architects.

### § 1.4 Interpretation

In the interest of brevity the Contract Documents frequently omit modifying words such as "all" and "any" and articles such as "the" and "an," but the fact that a modifier or an article is absent from one statement and appears in another is not intended to affect the interpretation of either statement.

### § 1.5 Ownership and Use of Drawings, Specifications, and Other Instruments of Service

§ 1.5.1 The Architect and the Architect's consultants shall be deemed the authors and owners of their respective Instruments of Service, including the Drawings and Specifications, and retain all common law, statutory, and other reserved rights in their Instruments of Service, including copyrights. The Contractor, Subcontractors, Sub-subcontractors, and suppliers shall not own or claim a copyright in the Instruments of Service. Submittal or distribution to meet official regulatory requirements or for other purposes in connection with the Project is not to be construed as publication in derogation of the Architect's or Architect's consultants' reserved rights.

§ 1.5.2 The Contractor, Subcontractors, Sub-subcontractors, and suppliers are authorized to use and reproduce the Instruments of Service provided to them, subject to any protocols established pursuant to Sections 1.7 and 1.8, solely and exclusively for execution of the Work. All copies made under this authorization shall bear the copyright notice, if any, shown on the Instruments of Service. The Contractor, Subcontractors, Sub-subcontractors, and suppliers may not use the Instruments of Service on other projects or for additions to the Project outside the scope of the Work without the specific written consent of the Owner, Architect, and the Architect's consultants.

### § 1.6 Notice

§ 1.6.1 Except as otherwise provided in Section 1.6.2, where the Contract Documents require one party to notify or give notice to the other party, such notice shall be provided in writing to the designated representative of the party to whom the notice is addressed and shall be deemed to have been duly served if delivered in person, by mail, by courier, or by electronic transmission if a method for electronic transmission is set forth in the Agreement.

§ 1.6.2 Notice of Claims as provided in Section 15.1.3 shall be provided in writing and shall be deemed to have been duly served only if delivered to the designated representative of the party to whom the notice is addressed by certified or registered mail, or by courier providing proof of delivery.

### § 1.7 Digital Data Use and Transmission

The parties shall agree upon protocols governing the transmission and use of Instruments of Service or any other information or documentation in digital form. The parties will use AIA Document E203™–2013, Building Information Modeling and Digital Data Exhibit, to establish the protocols for the development, use, transmission, and exchange of digital data.

### § 1.8 Building Information Models Use and Reliance

Any use of, or reliance on, all or a portion of a building information model without agreement to protocols governing the use of, and reliance on, the information contained in the model and without having those protocols set forth in AIA Document E203™–2013, Building Information Modeling and Digital Data Exhibit, and the requisite AIA Document

G202™–2013, Project Building Information Modeling Protocol Form, shall be at the using or relying party's sole risk and without liability to the other party and its contractors or consultants, the authors of, or contributors to, the building information model, and each of their agents and employees.

## **ARTICLE 2 OWNER**

### **§ 2.1 General**

**§ 2.1.1** The Owner is the person or entity identified as such in the Agreement and is referred to throughout the Contract Documents as if singular in number. The Owner shall designate in writing a representative who shall have express authority to bind the Owner with respect to all matters requiring the Owner's approval or authorization. Except as otherwise provided in Section 4.2.1, the Architect does not have such authority. The term "Owner" means the Owner or the Owner's authorized representative.

**§ 2.1.2** The Owner shall furnish to the Contractor, within fifteen days after receipt of a written request, information necessary and relevant for the Contractor to evaluate, give notice of, or enforce mechanic's lien rights. Such information shall include a correct statement of the record legal title to the property on which the Project is located, usually referred to as the site, and the Owner's interest therein.

### **§ 2.2 Evidence of the Owner's Financial Arrangements**

**§ 2.2.1** Prior to commencement of the Work and upon written request by the Contractor, the Owner shall furnish to the Contractor reasonable evidence that the Owner has made financial arrangements to fulfill the Owner's obligations under the Contract. The Contractor shall have no obligation to commence the Work until the Owner provides such evidence. If commencement of the Work is delayed under this Section 2.2.1, the Contract Time shall be extended appropriately.

**§ 2.2.2** Following commencement of the Work and upon written request by the Contractor, the Owner shall furnish to the Contractor reasonable evidence that the Owner has made financial arrangements to fulfill the Owner's obligations under the Contract only if (1) the Owner fails to make payments to the Contractor as the Contract Documents require; (2) the Contractor identifies in writing a reasonable concern regarding the Owner's ability to make payment when due; or (3) a change in the Work materially changes the Contract Sum. If the Owner fails to provide such evidence, as required, within fourteen days of the Contractor's request, the Contractor may immediately stop the Work and, in that event, shall notify the Owner that the Work has stopped. However, if the request is made because a change in the Work materially changes the Contract Sum under (3) above, the Contractor may immediately stop only that portion of the Work affected by the change until reasonable evidence is provided. If the Work is stopped under this Section 2.2.2, the Contract Time shall be extended appropriately and the Contract Sum shall be increased by the amount of the Contractor's reasonable costs of shutdown, delay and start-up, plus interest as provided in the Contract Documents.

**§ 2.2.3** After the Owner furnishes evidence of financial arrangements under this Section 2.2, the Owner shall not materially vary such financial arrangements without prior notice to the Contractor.

**§ 2.2.4** Where the Owner has designated information furnished under this Section 2.2 as "confidential," the Contractor shall keep the information confidential and shall not disclose it to any other person. However, the Contractor may disclose "confidential" information, after seven (7) days' notice to the Owner, where disclosure is required by law, including a subpoena or other form of compulsory legal process issued by a court or governmental entity, or by court or arbitrator(s) order. The Contractor may also disclose "confidential" information to its employees, consultants, sureties, Subcontractors and their employees, Sub-subcontractors, and others who need to know the content of such information solely and exclusively for the Project and who agree to maintain the confidentiality of such information.

### **§ 2.3 Information and Services Required of the Owner**

**§ 2.3.1** Except for permits and fees that are the responsibility of the Contractor under the Contract Documents, including those required under Section 3.7.1, the Owner shall secure and pay for necessary approvals, easements, assessments and charges required for construction, use or occupancy of permanent structures or for permanent changes in existing facilities.

**§ 2.3.2** The Owner shall retain an architect lawfully licensed to practice architecture, or an entity lawfully practicing architecture, in the jurisdiction where the Project is located. That person or entity is identified as the Architect in the Agreement and is referred to throughout the Contract Documents as if singular in number.

§ 2.3.3 If the employment of the Architect terminates, the Owner shall employ a successor to whom the Contractor has no reasonable objection and whose status under the Contract Documents shall be that of the Architect.

§ 2.3.4 The Owner shall furnish surveys describing physical characteristics, legal limitations and utility locations for the site of the Project, and a legal description of the site. The Contractor shall be entitled to rely on the accuracy of information furnished by the Owner but shall exercise proper precautions relating to the safe performance of the Work.

§ 2.3.5 The Owner shall furnish information or services required of the Owner by the Contract Documents with reasonable promptness. The Owner shall also furnish any other information or services under the Owner's control and relevant to the Contractor's performance of the Work with reasonable promptness after receiving the Contractor's written request for such information or services.

§ 2.3.6 Unless otherwise provided in the Contract Documents, the Owner shall furnish to the Contractor one copy of the Contract Documents for purposes of making reproductions pursuant to Section 1.5.2.

#### § 2.4 Owner's Right to Stop the Work

If the Contractor fails to correct Work that is not in accordance with the requirements of the Contract Documents as required by Section 12.2 or repeatedly fails to carry out Work in accordance with the Contract Documents, the Owner may issue a written order to the Contractor to stop the Work, or any portion thereof, until the cause for such order has been eliminated; however, the right of the Owner to stop the Work shall not give rise to a duty on the part of the Owner to exercise this right for the benefit of the Contractor or any other person or entity, except to the extent required by Section 6.1.3.

#### § 2.5 Owner's Right to Carry Out the Work

If the Contractor defaults or neglects to carry out the Work in accordance with the Contract Documents and fails within a ten-day period after receipt of notice from the Owner to commence and continue correction of such default or neglect with diligence and promptness, the Owner may, without prejudice to other remedies the Owner may have, correct such default or neglect. Such action by the Owner and amounts charged to the Contractor are both subject to prior approval of the Architect and the Architect may, pursuant to Section 9.5.1, withhold or nullify a Certificate for Payment in whole or in part, to the extent reasonably necessary to reimburse the Owner for the reasonable cost of correcting such deficiencies, including Owner's expenses and compensation for the Architect's additional services made necessary by such default, neglect, or failure. If current and future payments are not sufficient to cover such amounts, the Contractor shall pay the difference to the Owner. If the Contractor disagrees with the actions of the Owner or the Architect, or the amounts claimed as costs to the Owner, the Contractor may file a Claim pursuant to Article 15.

### ARTICLE 3 CONTRACTOR

#### § 3.1 General

§ 3.1.1 The Contractor is the person or entity identified as such in the Agreement and is referred to throughout the Contract Documents as if singular in number. The Contractor shall be lawfully licensed, if required in the jurisdiction where the Project is located. The Contractor shall designate in writing a representative who shall have express authority to bind the Contractor with respect to all matters under this Contract. The term "Contractor" means the Contractor or the Contractor's authorized representative.

§ 3.1.2 The Contractor shall perform the Work in accordance with the Contract Documents.

§ 3.1.3 The Contractor shall not be relieved of its obligations to perform the Work in accordance with the Contract Documents either by activities or duties of the Architect in the Architect's administration of the Contract, or by tests, inspections or approvals required or performed by persons or entities other than the Contractor.

#### § 3.2 Review of Contract Documents and Field Conditions by Contractor

§ 3.2.1 Execution of the Contract by the Contractor is a representation that the Contractor has visited the site, become generally familiar with local conditions under which the Work is to be performed, and correlated personal observations with requirements of the Contract Documents.



§ 3.2.2 Because the Contract Documents are complementary, the Contractor shall, before starting each portion of the Work, carefully study and compare the various Contract Documents relative to that portion of the Work, as well as the information furnished by the Owner pursuant to Section 2.3.4, shall take field measurements of any existing conditions related to that portion of the Work, and shall observe any conditions at the site affecting it. These obligations are for the purpose of facilitating coordination and construction by the Contractor and are not for the purpose of discovering errors, omissions, or inconsistencies in the Contract Documents; however, the Contractor shall promptly report to the Architect any errors, inconsistencies or omissions discovered by or made known to the Contractor as a request for information in such form as the Architect may require. It is recognized that the Contractor's review is made in the Contractor's capacity as a contractor and not as a licensed design professional, unless otherwise specifically provided in the Contract Documents.

§ 3.2.3 The Contractor is not required to ascertain that the Contract Documents are in accordance with applicable laws, statutes, ordinances, codes, rules and regulations, or lawful orders of public authorities, but the Contractor shall promptly report to the Architect any nonconformity discovered by or made known to the Contractor as a request for information in such form as the Architect may require.

§ 3.2.4 If the Contractor believes that additional cost or time is involved because of clarifications or instructions the Architect issues in response to the Contractor's notices or requests for information pursuant to Sections 3.2.2 or 3.2.3, the Contractor shall submit Claims as provided in Article 15. If the Contractor fails to perform the obligations of Sections 3.2.2 or 3.2.3, the Contractor shall pay such costs and damages to the Owner, subject to Section 15.1.7, as would have been avoided if the Contractor had performed such obligations. If the Contractor performs those obligations, the Contractor shall not be liable to the Owner or Architect for damages resulting from errors, inconsistencies or omissions in the Contract Documents, for differences between field measurements or conditions and the Contract Documents, or for nonconformities of the Contract Documents to applicable laws, statutes, ordinances, codes, rules and regulations, and lawful orders of public authorities.

### § 3.3 Supervision and Construction Procedures

§ 3.3.1 The Contractor shall supervise and direct the Work, using the Contractor's best skill and attention. The Contractor shall be solely responsible for, and have control over, construction means, methods, techniques, sequences, and procedures, and for coordinating all portions of the Work under the Contract. If the Contract Documents give specific instructions concerning construction means, methods, techniques, sequences, or procedures, the Contractor shall evaluate the jobsite safety thereof and shall be solely responsible for the jobsite safety of such means, methods, techniques, sequences, or procedures. If the Contractor determines that such means, methods, techniques, sequences or procedures may not be safe, the Contractor shall give timely notice to the Owner and Architect, and shall propose alternative means, methods, techniques, sequences, or procedures. The Architect shall evaluate the proposed alternative solely for conformance with the design intent for the completed construction. Unless the Architect objects to the Contractor's proposed alternative, the Contractor shall perform the Work using its alternative means, methods, techniques, sequences, or procedures.

§ 3.3.2 The Contractor shall be responsible to the Owner for acts and omissions of the Contractor's employees, Subcontractors and their agents and employees, and other persons or entities performing portions of the Work for, or on behalf of, the Contractor or any of its Subcontractors.

§ 3.3.3 The Contractor shall be responsible for inspection of portions of Work already performed to determine that such portions are in proper condition to receive subsequent Work.

### § 3.4 Labor and Materials

§ 3.4.1 Unless otherwise provided in the Contract Documents, the Contractor shall provide and pay for labor, materials, equipment, tools, construction equipment and machinery, water, heat, utilities, transportation, and other facilities and services necessary for proper execution and completion of the Work, whether temporary or permanent and whether or not incorporated or to be incorporated in the Work.

§ 3.4.2 Except in the case of minor changes in the Work approved by the Architect in accordance with Section 3.12.8 or ordered by the Architect in accordance with Section 7.4, the Contractor may make substitutions only with the consent of the Owner, after evaluation by the Architect and in accordance with a Change Order or Construction Change Directive.

§ 3.4.3 The Contractor shall enforce strict discipline and good order among the Contractor's employees and other persons carrying out the Work. The Contractor shall not permit employment of unfit persons or persons not properly skilled in tasks assigned to them.

### § 3.5 Warranty

§ 3.5.1 The Contractor warrants to the Owner and Architect that materials and equipment furnished under the Contract will be of good quality and new unless the Contract Documents require or permit otherwise. The Contractor further warrants that the Work will conform to the requirements of the Contract Documents and will be free from defects, except for those inherent in the quality of the Work the Contract Documents require or permit. Work, materials, or equipment not conforming to these requirements may be considered defective. The Contractor's warranty excludes remedy for damage or defect caused by abuse, alterations to the Work not executed by the Contractor, improper or insufficient maintenance, improper operation, or normal wear and tear and normal usage. If required by the Architect, the Contractor shall furnish satisfactory evidence as to the kind and quality of materials and equipment.

§ 3.5.2 All material, equipment, or other special warranties required by the Contract Documents shall be issued in the name of the Owner, or shall be transferable to the Owner, and shall commence in accordance with Section 9.8.4.

### § 3.6 Taxes

The Contractor shall pay sales, consumer, use and similar taxes for the Work provided by the Contractor that are legally enacted when bids are received or negotiations concluded, whether or not yet effective or merely scheduled to go into effect.

### § 3.7 Permits, Fees, Notices and Compliance with Laws

§ 3.7.1 Unless otherwise provided in the Contract Documents, the Contractor shall secure and pay for the building permit as well as for other permits, fees, licenses, and inspections by government agencies necessary for proper execution and completion of the Work that are customarily secured after execution of the Contract and legally required at the time bids are received or negotiations concluded.

§ 3.7.2 The Contractor shall comply with and give notices required by applicable laws, statutes, ordinances, codes, rules and regulations, and lawful orders of public authorities applicable to performance of the Work.

§ 3.7.3 If the Contractor performs Work knowing it to be contrary to applicable laws, statutes, ordinances, codes, rules and regulations, or lawful orders of public authorities, the Contractor shall assume appropriate responsibility for such Work and shall bear the costs attributable to correction.

### § 3.7.4 Concealed or Unknown Conditions

If the Contractor encounters conditions at the site that are (1) subsurface or otherwise concealed physical conditions that differ materially from those indicated in the Contract Documents or (2) unknown physical conditions of an unusual nature that differ materially from those ordinarily found to exist and generally recognized as inherent in construction activities of the character provided for in the Contract Documents, the Contractor shall promptly provide notice to the Owner and the Architect before conditions are disturbed and in no event later than 14 days after first observance of the conditions. The Architect will promptly investigate such conditions and, if the Architect determines that they differ materially and cause an increase or decrease in the Contractor's cost of, or time required for, performance of any part of the Work, will recommend that an equitable adjustment be made in the Contract Sum or Contract Time, or both. If the Architect determines that the conditions at the site are not materially different from those indicated in the Contract Documents and that no change in the terms of the Contract is justified, the Architect shall promptly notify the Owner and Contractor, stating the reasons. If either party disputes the Architect's determination or recommendation, that party may submit a Claim as provided in Article 15.

§ 3.7.5 If, in the course of the Work, the Contractor encounters human remains or recognizes the existence of burial markers, archaeological sites or wetlands not indicated in the Contract Documents, the Contractor shall immediately suspend any operations that would affect them and shall notify the Owner and Architect. Upon receipt of such notice, the Owner shall promptly take any action necessary to obtain governmental authorization required to resume the operations. The Contractor shall continue to suspend such operations until otherwise instructed by the Owner but shall continue with all other operations that do not affect those remains or features. Requests for adjustments in the Contract Sum and Contract Time arising from the existence of such remains or features may be made as provided in Article 15.

### § 3.8 Allowances

§ 3.8.1 The Contractor shall include in the Contract Sum all allowances stated in the Contract Documents. Items covered by allowances shall be supplied for such amounts and by such persons or entities as the Owner may direct, but the Contractor shall not be required to employ persons or entities to whom the Contractor has reasonable objection.

§ 3.8.2 Unless otherwise provided in the Contract Documents,

- .1 allowances shall cover the cost to the Contractor of materials and equipment delivered at the site and all required taxes, less applicable trade discounts;
- .2 Contractor's costs for unloading and handling at the site, labor, installation costs, overhead, profit, and other expenses contemplated for stated allowance amounts shall be included in the Contract Sum but not in the allowances; and
- .3 whenever costs are more than or less than allowances, the Contract Sum shall be adjusted accordingly by Change Order. The amount of the Change Order shall reflect (1) the difference between actual costs and the allowances under Section 3.8.2.1 and (2) changes in Contractor's costs under Section 3.8.2.2.

§ 3.8.3 Materials and equipment under an allowance shall be selected by the Owner with reasonable promptness.

### § 3.9 Superintendent

§ 3.9.1 The Contractor shall employ a competent superintendent and necessary assistants who shall be in attendance at the Project site during performance of the Work. The superintendent shall represent the Contractor, and communications given to the superintendent shall be as binding as if given to the Contractor.

§ 3.9.2 The Contractor, as soon as practicable after award of the Contract, shall notify the Owner and Architect of the name and qualifications of a proposed superintendent. Within 14 days of receipt of the information, the Architect may notify the Contractor, stating whether the Owner or the Architect (1) has reasonable objection to the proposed superintendent or (2) requires additional time for review. Failure of the Architect to provide notice within the 14-day period shall constitute notice of no reasonable objection.

§ 3.9.3 The Contractor shall not employ a proposed superintendent to whom the Owner or Architect has made reasonable and timely objection. The Contractor shall not change the superintendent without the Owner's consent, which shall not unreasonably be withheld or delayed.

### § 3.10 Contractor's Construction and Submittal Schedules

§ 3.10.1 The Contractor, promptly after being awarded the Contract, shall submit for the Owner's and Architect's information a Contractor's construction schedule for the Work. The schedule shall contain detail appropriate for the Project, including (1) the date of commencement of the Work, interim schedule milestone dates, and the date of Substantial Completion; (2) an apportionment of the Work by construction activity; and (3) the time required for completion of each portion of the Work. The schedule shall provide for the orderly progression of the Work to completion and shall not exceed time limits current under the Contract Documents. The schedule shall be revised at appropriate intervals as required by the conditions of the Work and Project.

§ 3.10.2 The Contractor, promptly after being awarded the Contract and thereafter as necessary to maintain a current submittal schedule, shall submit a submittal schedule for the Architect's approval. The Architect's approval shall not be unreasonably delayed or withheld. The submittal schedule shall (1) be coordinated with the Contractor's construction schedule, and (2) allow the Architect reasonable time to review submittals. If the Contractor fails to submit a submittal schedule, or fails to provide submittals in accordance with the approved submittal schedule, the Contractor shall not be entitled to any increase in Contract Sum or extension of Contract Time based on the time required for review of submittals.

§ 3.10.3 The Contractor shall perform the Work in general accordance with the most recent schedules submitted to the Owner and Architect.

### § 3.11 Documents and Samples at the Site

The Contractor shall make available, at the Project site, the Contract Documents, including Change Orders, Construction Change Directives, and other Modifications, in good order and marked currently to indicate field changes and selections made during construction, and the approved Shop Drawings, Product Data, Samples, and similar required submittals. These shall be in electronic form or paper copy, available to the Architect and Owner, and



delivered to the Architect for submittal to the Owner upon completion of the Work as a record of the Work as constructed.

**§ 3.12 Shop Drawings, Product Data and Samples**

**§ 3.12.1** Shop Drawings are drawings, diagrams, schedules, and other data specially prepared for the Work by the Contractor or a Subcontractor, Sub-subcontractor, manufacturer, supplier, or distributor to illustrate some portion of the Work.

**§ 3.12.2** Product Data are illustrations, standard schedules, performance charts, instructions, brochures, diagrams, and other information furnished by the Contractor to illustrate materials or equipment for some portion of the Work.

**§ 3.12.3** Samples are physical examples that illustrate materials, equipment, or workmanship, and establish standards by which the Work will be judged.

**§ 3.12.4** Shop Drawings, Product Data, Samples, and similar submittals are not Contract Documents. Their purpose is to demonstrate how the Contractor proposes to conform to the information given and the design concept expressed in the Contract Documents for those portions of the Work for which the Contract Documents require submittals. Review by the Architect is subject to the limitations of Section 4.2.7. Informational submittals upon which the Architect is not expected to take responsive action may be so identified in the Contract Documents. Submittals that are not required by the Contract Documents may be returned by the Architect without action.

**§ 3.12.5** The Contractor shall review for compliance with the Contract Documents, approve, and submit to the Architect, Shop Drawings, Product Data, Samples, and similar submittals required by the Contract Documents, in accordance with the submittal schedule approved by the Architect or, in the absence of an approved submittal schedule, with reasonable promptness and in such sequence as to cause no delay in the Work or in the activities of the Owner or of Separate Contractors.

**§ 3.12.6** By submitting Shop Drawings, Product Data, Samples, and similar submittals, the Contractor represents to the Owner and Architect that the Contractor has (1) reviewed and approved them, (2) determined and verified materials, field measurements and field construction criteria related thereto, or will do so, and (3) checked and coordinated the information contained within such submittals with the requirements of the Work and of the Contract Documents.

**§ 3.12.7** The Contractor shall perform no portion of the Work for which the Contract Documents require submittal and review of Shop Drawings, Product Data, Samples, or similar submittals, until the respective submittal has been approved by the Architect.

**§ 3.12.8** The Work shall be in accordance with approved submittals except that the Contractor shall not be relieved of responsibility for deviations from the requirements of the Contract Documents by the Architect's approval of Shop Drawings, Product Data, Samples, or similar submittals, unless the Contractor has specifically notified the Architect of such deviation at the time of submittal and (1) the Architect has given written approval to the specific deviation as a minor change in the Work, or (2) a Change Order or Construction Change Directive has been issued authorizing the deviation. The Contractor shall not be relieved of responsibility for errors or omissions in Shop Drawings, Product Data, Samples, or similar submittals, by the Architect's approval thereof.

**§ 3.12.9** The Contractor shall direct specific attention, in writing or on resubmitted Shop Drawings, Product Data, Samples, or similar submittals, to revisions other than those requested by the Architect on previous submittals. In the absence of such notice, the Architect's approval of a resubmission shall not apply to such revisions.

**§ 3.12.10** The Contractor shall not be required to provide professional services that constitute the practice of architecture or engineering unless such services are specifically required by the Contract Documents for a portion of the Work or unless the Contractor needs to provide such services in order to carry out the Contractor's responsibilities for construction means, methods, techniques, sequences, and procedures. The Contractor shall not be required to provide professional services in violation of applicable law.

**§ 3.12.10.1** If professional design services or certifications by a design professional related to systems, materials, or equipment are specifically required of the Contractor by the Contract Documents, the Owner and the Architect will

specify all performance and design criteria that such services must satisfy. The Contractor shall be entitled to rely upon the adequacy and accuracy of the performance and design criteria provided in the Contract Documents. The Contractor shall cause such services or certifications to be provided by an appropriately licensed design professional, whose signature and seal shall appear on all drawings, calculations, specifications, certifications, Shop Drawings, and other submittals prepared by such professional. Shop Drawings, and other submittals related to the Work, designed or certified by such professional, if prepared by others, shall bear such professional's written approval when submitted to the Architect. The Owner and the Architect shall be entitled to rely upon the adequacy and accuracy of the services, certifications, and approvals performed or provided by such design professionals, provided the Owner and Architect have specified to the Contractor the performance and design criteria that such services must satisfy. Pursuant to this Section 3.12.10, the Architect will review and approve or take other appropriate action on submittals only for the limited purpose of checking for conformance with information given and the design concept expressed in the Contract Documents.

**§ 3.12.10.2** If the Contract Documents require the Contractor's design professional to certify that the Work has been performed in accordance with the design criteria, the Contractor shall furnish such certifications to the Architect at the time and in the form specified by the Architect.

### **§ 3.13 Use of Site**

The Contractor shall confine operations at the site to areas permitted by applicable laws, statutes, ordinances, codes, rules and regulations, lawful orders of public authorities, and the Contract Documents and shall not unreasonably encumber the site with materials or equipment.

### **§ 3.14 Cutting and Patching**

**§ 3.14.1** The Contractor shall be responsible for cutting, fitting, or patching required to complete the Work or to make its parts fit together properly. All areas requiring cutting, fitting, or patching shall be restored to the condition existing prior to the cutting, fitting, or patching, unless otherwise required by the Contract Documents.

**§ 3.14.2** The Contractor shall not damage or endanger a portion of the Work or fully or partially completed construction of the Owner or Separate Contractors by cutting, patching, or otherwise altering such construction, or by excavation. The Contractor shall not cut or otherwise alter construction by the Owner or a Separate Contractor except with written consent of the Owner and of the Separate Contractor. Consent shall not be unreasonably withheld. The Contractor shall not unreasonably withhold, from the Owner or a Separate Contractor, its consent to cutting or otherwise altering the Work.

### **§ 3.15 Cleaning Up**

**§ 3.15.1** The Contractor shall keep the premises and surrounding area free from accumulation of waste materials and rubbish caused by operations under the Contract. At completion of the Work, the Contractor shall remove waste materials, rubbish, the Contractor's tools, construction equipment, machinery, and surplus materials from and about the Project.

**§ 3.15.2** If the Contractor fails to clean up as provided in the Contract Documents, the Owner may do so and the Owner shall be entitled to reimbursement from the Contractor.

### **§ 3.16 Access to Work**

The Contractor shall provide the Owner and Architect with access to the Work in preparation and progress wherever located.

### **§ 3.17 Royalties, Patents and Copyrights**

The Contractor shall pay all royalties and license fees. The Contractor shall defend suits or claims for infringement of copyrights and patent rights and shall hold the Owner and Architect harmless from loss on account thereof, but shall not be responsible for defense or loss when a particular design, process, or product of a particular manufacturer or manufacturers is required by the Contract Documents, or where the copyright violations are contained in Drawings, Specifications, or other documents prepared by the Owner or Architect. However, if an infringement of a copyright or patent is discovered by, or made known to, the Contractor, the Contractor shall be responsible for the loss unless the information is promptly furnished to the Architect.

### § 3.18 Indemnification

§ 3.18.1 To the fullest extent permitted by law, the Contractor shall indemnify and hold harmless the Owner, Architect, Architect's consultants, and agents and employees of any of them from and against claims, damages, losses, and expenses, including but not limited to attorneys' fees, arising out of or resulting from performance of the Work, provided that such claim, damage, loss, or expense is attributable to bodily injury, sickness, disease or death, or to injury to or destruction of tangible property (other than the Work itself), but only to the extent caused by the negligent acts or omissions of the Contractor, a Subcontractor, anyone directly or indirectly employed by them, or anyone for whose acts they may be liable, regardless of whether or not such claim, damage, loss, or expense is caused in part by a party indemnified hereunder. Such obligation shall not be construed to negate, abridge, or reduce other rights or obligations of indemnity that would otherwise exist as to a party or person described in this Section 3.18.

§ 3.18.2 In claims against any person or entity indemnified under this Section 3.18 by an employee of the Contractor, a Subcontractor, anyone directly or indirectly employed by them, or anyone for whose acts they may be liable, the indemnification obligation under Section 3.18.1 shall not be limited by a limitation on amount or type of damages, compensation, or benefits payable by or for the Contractor or a Subcontractor under workers' compensation acts, disability benefit acts, or other employee benefit acts.

## ARTICLE 4 ARCHITECT

### § 4.1 General

§ 4.1.1 The Architect is the person or entity retained by the Owner pursuant to Section 2.3.2 and identified as such in the Agreement.

§ 4.1.2 Duties, responsibilities, and limitations of authority of the Architect as set forth in the Contract Documents shall not be restricted, modified, or extended without written consent of the Owner, Contractor, and Architect. Consent shall not be unreasonably withheld.

### § 4.2 Administration of the Contract

§ 4.2.1 The Architect will provide administration of the Contract as described in the Contract Documents and will be an Owner's representative during construction until the date the Architect issues the final Certificate for Payment. The Architect will have authority to act on behalf of the Owner only to the extent provided in the Contract Documents.

§ 4.2.2 The Architect will visit the site at intervals appropriate to the stage of construction, or as otherwise agreed with the Owner, to become generally familiar with the progress and quality of the portion of the Work completed, and to determine in general if the Work observed is being performed in a manner indicating that the Work, when fully completed, will be in accordance with the Contract Documents. However, the Architect will not be required to make exhaustive or continuous on-site inspections to check the quality or quantity of the Work. The Architect will not have control over, charge of, or responsibility for the construction means, methods, techniques, sequences or procedures, or for the safety precautions and programs in connection with the Work, since these are solely the Contractor's rights and responsibilities under the Contract Documents.

§ 4.2.3 On the basis of the site visits, the Architect will keep the Owner reasonably informed about the progress and quality of the portion of the Work completed, and promptly report to the Owner (1) known deviations from the Contract Documents, (2) known deviations from the most recent construction schedule submitted by the Contractor, and (3) defects and deficiencies observed in the Work. The Architect will not be responsible for the Contractor's failure to perform the Work in accordance with the requirements of the Contract Documents. The Architect will not have control over or charge of, and will not be responsible for acts or omissions of, the Contractor, Subcontractors, or their agents or employees, or any other persons or entities performing portions of the Work.

### § 4.2.4 Communications

The Owner and Contractor shall include the Architect in all communications that relate to or affect the Architect's services or professional responsibilities. The Owner shall promptly notify the Architect of the substance of any direct communications between the Owner and the Contractor otherwise relating to the Project. Communications by and with the Architect's consultants shall be through the Architect. Communications by and with Subcontractors and suppliers shall be through the Contractor. Communications by and with Separate Contractors shall be through the Owner. The Contract Documents may specify other communication protocols.

§ 4.2.5 Based on the Architect's evaluations of the Contractor's Applications for Payment, the Architect will review and certify the amounts due the Contractor and will issue Certificates for Payment in such amounts.

§ 4.2.6 The Architect has authority to reject Work that does not conform to the Contract Documents. Whenever the Architect considers it necessary or advisable, the Architect will have authority to require inspection or testing of the Work in accordance with Sections 13.4.2 and 13.4.3, whether or not the Work is fabricated, installed or completed. However, neither this authority of the Architect nor a decision made in good faith either to exercise or not to exercise such authority shall give rise to a duty or responsibility of the Architect to the Contractor, Subcontractors, suppliers, their agents or employees, or other persons or entities performing portions of the Work.

§ 4.2.7 The Architect will review and approve, or take other appropriate action upon, the Contractor's submittals such as Shop Drawings, Product Data, and Samples, but only for the limited purpose of checking for conformance with information given and the design concept expressed in the Contract Documents. The Architect's action will be taken in accordance with the submittal schedule approved by the Architect or, in the absence of an approved submittal schedule, with reasonable promptness while allowing sufficient time in the Architect's professional judgment to permit adequate review. Review of such submittals is not conducted for the purpose of determining the accuracy and completeness of other details such as dimensions and quantities, or for substantiating instructions for installation or performance of equipment or systems, all of which remain the responsibility of the Contractor as required by the Contract Documents. The Architect's review of the Contractor's submittals shall not relieve the Contractor of the obligations under Sections 3.3, 3.5, and 3.12. The Architect's review shall not constitute approval of safety precautions or of any construction means, methods, techniques, sequences, or procedures. The Architect's approval of a specific item shall not indicate approval of an assembly of which the item is a component.

§ 4.2.8 The Architect will prepare Change Orders and Construction Change Directives, and may order minor changes in the Work as provided in Section 7.4. The Architect will investigate and make determinations and recommendations regarding concealed and unknown conditions as provided in Section 3.7.4.

§ 4.2.9 The Architect will conduct inspections to determine the date or dates of Substantial Completion and the date of final completion; issue Certificates of Substantial Completion pursuant to Section 9.8; receive and forward to the Owner, for the Owner's review and records, written warranties and related documents required by the Contract and assembled by the Contractor pursuant to Section 9.10; and issue a final Certificate for Payment pursuant to Section 9.10.

§ 4.2.10 If the Owner and Architect agree, the Architect will provide one or more Project representatives to assist in carrying out the Architect's responsibilities at the site. The Owner shall notify the Contractor of any change in the duties, responsibilities and limitations of authority of the Project representatives.

§ 4.2.11 The Architect will interpret and decide matters concerning performance under, and requirements of, the Contract Documents on written request of either the Owner or Contractor. The Architect's response to such requests will be made in writing within any time limits agreed upon or otherwise with reasonable promptness.

§ 4.2.12 Interpretations and decisions of the Architect will be consistent with the intent of, and reasonably inferable from, the Contract Documents and will be in writing or in the form of drawings. When making such interpretations and decisions, the Architect will endeavor to secure faithful performance by both Owner and Contractor, will not show partiality to either, and will not be liable for results of interpretations or decisions rendered in good faith.

§ 4.2.13 The Architect's decisions on matters relating to aesthetic effect will be final if consistent with the intent expressed in the Contract Documents.

§ 4.2.14 The Architect will review and respond to requests for information about the Contract Documents. The Architect's response to such requests will be made in writing within any time limits agreed upon or otherwise with reasonable promptness. If appropriate, the Architect will prepare and issue supplemental Drawings and Specifications in response to the requests for information.



## ARTICLE 5 SUBCONTRACTORS

### § 5.1 Definitions

§ 5.1.1 A Subcontractor is a person or entity who has a direct contract with the Contractor to perform a portion of the Work at the site. The term "Subcontractor" is referred to throughout the Contract Documents as if singular in number and means a Subcontractor or an authorized representative of the Subcontractor. The term "Subcontractor" does not include a Separate Contractor or the subcontractors of a Separate Contractor.

§ 5.1.2 A Sub-subcontractor is a person or entity who has a direct or indirect contract with a Subcontractor to perform a portion of the Work at the site. The term "Sub-subcontractor" is referred to throughout the Contract Documents as if singular in number and means a Sub-subcontractor or an authorized representative of the Sub-subcontractor.

### § 5.2 Award of Subcontracts and Other Contracts for Portions of the Work

§ 5.2.1 Unless otherwise stated in the Contract Documents, the Contractor, as soon as practicable after award of the Contract, shall notify the Owner and Architect of the persons or entities proposed for each principal portion of the Work, including those who are to furnish materials or equipment fabricated to a special design. Within 14 days of receipt of the information, the Architect may notify the Contractor whether the Owner or the Architect (1) has reasonable objection to any such proposed person or entity or (2) requires additional time for review. Failure of the Architect to provide notice within the 14-day period shall constitute notice of no reasonable objection.

§ 5.2.2 The Contractor shall not contract with a proposed person or entity to whom the Owner or Architect has made reasonable and timely objection. The Contractor shall not be required to contract with anyone to whom the Contractor has made reasonable objection.

§ 5.2.3 If the Owner or Architect has reasonable objection to a person or entity proposed by the Contractor, the Contractor shall propose another to whom the Owner or Architect has no reasonable objection. If the proposed but rejected Subcontractor was reasonably capable of performing the Work, the Contract Sum and Contract Time shall be increased or decreased by the difference, if any, occasioned by such change, and an appropriate Change Order shall be issued before commencement of the substitute Subcontractor's Work. However, no increase in the Contract Sum or Contract Time shall be allowed for such change unless the Contractor has acted promptly and responsively in submitting names as required.

§ 5.2.4 The Contractor shall not substitute a Subcontractor, person, or entity for one previously selected if the Owner or Architect makes reasonable objection to such substitution.

### § 5.3 Subcontractual Relations

By appropriate written agreement, the Contractor shall require each Subcontractor, to the extent of the Work to be performed by the Subcontractor, to be bound to the Contractor by terms of the Contract Documents, and to assume toward the Contractor all the obligations and responsibilities, including the responsibility for safety of the Subcontractor's Work that the Contractor, by these Contract Documents, assumes toward the Owner and Architect. Each subcontract agreement shall preserve and protect the rights of the Owner and Architect under the Contract Documents with respect to the Work to be performed by the Subcontractor so that subcontracting thereof will not prejudice such rights, and shall allow to the Subcontractor, unless specifically provided otherwise in the subcontract agreement, the benefit of all rights, remedies, and redress against the Contractor that the Contractor, by the Contract Documents, has against the Owner. Where appropriate, the Contractor shall require each Subcontractor to enter into similar agreements with Sub-subcontractors. The Contractor shall make available to each proposed Subcontractor, prior to the execution of the subcontract agreement, copies of the Contract Documents to which the Subcontractor will be bound, and, upon written request of the Subcontractor, identify to the Subcontractor terms and conditions of the proposed subcontract agreement that may be at variance with the Contract Documents. Subcontractors will similarly make copies of applicable portions of such documents available to their respective proposed Sub-subcontractors.

### § 5.4 Contingent Assignment of Subcontracts

§ 5.4.1 Each subcontract agreement for a portion of the Work is assigned by the Contractor to the Owner, provided that

- .1 assignment is effective only after termination of the Contract by the Owner for cause pursuant to Section 14.2 and only for those subcontract agreements that the Owner accepts by notifying the Subcontractor and Contractor; and
- .2 assignment is subject to the prior rights of the surety, if any, obligated under bond relating to the Contract.



When the Owner accepts the assignment of a subcontract agreement, the Owner assumes the Contractor's rights and obligations under the subcontract.

§ 5.4.2 Upon such assignment, if the Work has been suspended for more than 30 days, the Subcontractor's compensation shall be equitably adjusted for increases in cost resulting from the suspension.

§ 5.4.3 Upon assignment to the Owner under this Section 5.4, the Owner may further assign the subcontract to a successor contractor or other entity. If the Owner assigns the subcontract to a successor contractor or other entity, the Owner shall nevertheless remain legally responsible for all of the successor contractor's obligations under the subcontract.

## **ARTICLE 6 CONSTRUCTION BY OWNER OR BY SEPARATE CONTRACTORS**

### **§ 6.1 Owner's Right to Perform Construction and to Award Separate Contracts**

§ 6.1.1 The term "Separate Contractor(s)" shall mean other contractors retained by the Owner under separate agreements. The Owner reserves the right to perform construction or operations related to the Project with the Owner's own forces, and with Separate Contractors retained under Conditions of the Contract substantially similar to those of this Contract, including those provisions of the Conditions of the Contract related to insurance and waiver of subrogation.

§ 6.1.2 When separate contracts are awarded for different portions of the Project or other construction or operations on the site, the term "Contractor" in the Contract Documents in each case shall mean the Contractor who executes each separate Owner-Contractor Agreement.

§ 6.1.3 The Owner shall provide for coordination of the activities of the Owner's own forces and of each Separate Contractor with the Work of the Contractor, who shall cooperate with them. The Contractor shall participate with any Separate Contractors and the Owner in reviewing their construction schedules. The Contractor shall make any revisions to its construction schedule deemed necessary after a joint review and mutual agreement. The construction schedules shall then constitute the schedules to be used by the Contractor, Separate Contractors, and the Owner until subsequently revised.

§ 6.1.4 Unless otherwise provided in the Contract Documents, when the Owner performs construction or operations related to the Project with the Owner's own forces or with Separate Contractors, the Owner or its Separate Contractors shall have the same obligations and rights that the Contractor has under the Conditions of the Contract, including, without excluding others, those stated in Article 3, this Article 6, and Articles 10, 11, and 12.

### **§ 6.2 Mutual Responsibility**

§ 6.2.1 The Contractor shall afford the Owner and Separate Contractors reasonable opportunity for introduction and storage of their materials and equipment and performance of their activities, and shall connect and coordinate the Contractor's construction and operations with theirs as required by the Contract Documents.

§ 6.2.2 If part of the Contractor's Work depends for proper execution or results upon construction or operations by the Owner or a Separate Contractor, the Contractor shall, prior to proceeding with that portion of the Work, promptly notify the Architect of apparent discrepancies or defects in the construction or operations by the Owner or Separate Contractor that would render it unsuitable for proper execution and results of the Contractor's Work. Failure of the Contractor to notify the Architect of apparent discrepancies or defects prior to proceeding with the Work shall constitute an acknowledgment that the Owner's or Separate Contractor's completed or partially completed construction is fit and proper to receive the Contractor's Work. The Contractor shall not be responsible for discrepancies or defects in the construction or operations by the Owner or Separate Contractor that are not apparent.

§ 6.2.3 The Contractor shall reimburse the Owner for costs the Owner incurs that are payable to a Separate Contractor because of the Contractor's delays, improperly timed activities or defective construction. The Owner shall be responsible to the Contractor for costs the Contractor incurs because of a Separate Contractor's delays, improperly timed activities, damage to the Work or defective construction.

§ 6.2.4 The Contractor shall promptly remedy damage that the Contractor wrongfully causes to completed or partially completed construction or to property of the Owner or Separate Contractor as provided in Section 10.2.5.

§ 6.2.5 The Owner and each Separate Contractor shall have the same responsibilities for cutting and patching as are described for the Contractor in Section 3.14.

### § 6.3 Owner's Right to Clean Up

If a dispute arises among the Contractor, Separate Contractors, and the Owner as to the responsibility under their respective contracts for maintaining the premises and surrounding area free from waste materials and rubbish, the Owner may clean up and the Architect will allocate the cost among those responsible.

## ARTICLE 7 CHANGES IN THE WORK

### § 7.1 General

§ 7.1.1 Changes in the Work may be accomplished after execution of the Contract, and without invalidating the Contract, by Change Order, Construction Change Directive or order for a minor change in the Work, subject to the limitations stated in this Article 7 and elsewhere in the Contract Documents.

§ 7.1.2 A Change Order shall be based upon agreement among the Owner, Contractor, and Architect. A Construction Change Directive requires agreement by the Owner and Architect and may or may not be agreed to by the Contractor. An order for a minor change in the Work may be issued by the Architect alone.

§ 7.1.3 Changes in the Work shall be performed under applicable provisions of the Contract Documents. The Contractor shall proceed promptly with changes in the Work, unless otherwise provided in the Change Order, Construction Change Directive, or order for a minor change in the Work.

### § 7.2 Change Orders

§ 7.2.1 A Change Order is a written instrument prepared by the Architect and signed by the Owner, Contractor, and Architect stating their agreement upon all of the following:

- .1 The change in the Work;
- .2 The amount of the adjustment, if any, in the Contract Sum; and
- .3 The extent of the adjustment, if any, in the Contract Time.

### § 7.3 Construction Change Directives

§ 7.3.1 A Construction Change Directive is a written order prepared by the Architect and signed by the Owner and Architect, directing a change in the Work prior to agreement on adjustment, if any, in the Contract Sum or Contract Time, or both. The Owner may by Construction Change Directive, without invalidating the Contract, order changes in the Work within the general scope of the Contract consisting of additions, deletions, or other revisions, the Contract Sum and Contract Time being adjusted accordingly.

§ 7.3.2 A Construction Change Directive shall be used in the absence of total agreement on the terms of a Change Order.

§ 7.3.3 If the Construction Change Directive provides for an adjustment to the Contract Sum, the adjustment shall be based on one of the following methods:

- .1 Mutual acceptance of a lump sum properly itemized and supported by sufficient substantiating data to permit evaluation;
- .2 Unit prices stated in the Contract Documents or subsequently agreed upon;
- .3 Cost to be determined in a manner agreed upon by the parties and a mutually acceptable fixed or percentage fee; or
- .4 As provided in Section 7.3.4.

§ 7.3.4 If the Contractor does not respond promptly or disagrees with the method for adjustment in the Contract Sum, the Architect shall determine the adjustment on the basis of reasonable expenditures and savings of those performing the Work attributable to the change, including, in case of an increase in the Contract Sum, an amount for overhead and profit as set forth in the Agreement, or if no such amount is set forth in the Agreement, a reasonable amount. In such case, and also under Section 7.3.3.3, the Contractor shall keep and present, in such form as the Architect may prescribe, an itemized accounting together with appropriate supporting data. Unless otherwise provided in the Contract Documents, costs for the purposes of this Section 7.3.4 shall be limited to the following:

- .1 Costs of labor, including applicable payroll taxes, fringe benefits required by agreement or custom, workers' compensation insurance, and other employee costs approved by the Architect;
- .2 Costs of materials, supplies, and equipment, including cost of transportation, whether incorporated or consumed;
- .3 Rental costs of machinery and equipment, exclusive of hand tools, whether rented from the Contractor or others;
- .4 Costs of premiums for all bonds and insurance, permit fees, and sales, use, or similar taxes, directly related to the change; and
- .5 Costs of supervision and field office personnel directly attributable to the change.

§ 7.3.5 If the Contractor disagrees with the adjustment in the Contract Time, the Contractor may make a Claim in accordance with applicable provisions of Article 15.

§ 7.3.6 Upon receipt of a Construction Change Directive, the Contractor shall promptly proceed with the change in the Work involved and advise the Architect of the Contractor's agreement or disagreement with the method, if any, provided in the Construction Change Directive for determining the proposed adjustment in the Contract Sum or Contract Time.

§ 7.3.7 A Construction Change Directive signed by the Contractor indicates the Contractor's agreement therewith, including adjustment in Contract Sum and Contract Time or the method for determining them. Such agreement shall be effective immediately and shall be recorded as a Change Order.

§ 7.3.8 The amount of credit to be allowed by the Contractor to the Owner for a deletion or change that results in a net decrease in the Contract Sum shall be actual net cost as confirmed by the Architect. When both additions and credits covering related Work or substitutions are involved in a change, the allowance for overhead and profit shall be figured on the basis of net increase, if any, with respect to that change.

§ 7.3.9 Pending final determination of the total cost of a Construction Change Directive to the Owner, the Contractor may request payment for Work completed under the Construction Change Directive in Applications for Payment. The Architect will make an interim determination for purposes of monthly certification for payment for those costs and certify for payment the amount that the Architect determines, in the Architect's professional judgment, to be reasonably justified. The Architect's interim determination of cost shall adjust the Contract Sum on the same basis as a Change Order, subject to the right of either party to disagree and assert a Claim in accordance with Article 15.

§ 7.3.10 When the Owner and Contractor agree with a determination made by the Architect concerning the adjustments in the Contract Sum and Contract Time, or otherwise reach agreement upon the adjustments, such agreement shall be effective immediately and the Architect will prepare a Change Order. Change Orders may be issued for all or any part of a Construction Change Directive.

#### § 7.4 Minor Changes in the Work

The Architect may order minor changes in the Work that are consistent with the intent of the Contract Documents and do not involve an adjustment in the Contract Sum or an extension of the Contract Time. The Architect's order for minor changes shall be in writing. If the Contractor believes that the proposed minor change in the Work will affect the Contract Sum or Contract Time, the Contractor shall notify the Architect and shall not proceed to implement the change in the Work. If the Contractor performs the Work set forth in the Architect's order for a minor change without prior notice to the Architect that such change will affect the Contract Sum or Contract Time, the Contractor waives any adjustment to the Contract Sum or extension of the Contract Time.

### ARTICLE 8 TIME

#### § 8.1 Definitions

§ 8.1.1 Unless otherwise provided, Contract Time is the period of time, including authorized adjustments, allotted in the Contract Documents for Substantial Completion of the Work.

§ 8.1.2 The date of commencement of the Work is the date established in the Agreement.

§ 8.1.3 The date of Substantial Completion is the date certified by the Architect in accordance with Section 9.8.

§ 8.1.4 The term "day" as used in the Contract Documents shall mean calendar day unless otherwise specifically defined.

## § 8.2 Progress and Completion

§ 8.2.1 Time limits stated in the Contract Documents are of the essence of the Contract. By executing the Agreement, the Contractor confirms that the Contract Time is a reasonable period for performing the Work.

§ 8.2.2 The Contractor shall not knowingly, except by agreement or instruction of the Owner in writing, commence the Work prior to the effective date of insurance required to be furnished by the Contractor and Owner.

§ 8.2.3 The Contractor shall proceed expeditiously with adequate forces and shall achieve Substantial Completion within the Contract Time.

## § 8.3 Delays and Extensions of Time

§ 8.3.1 If the Contractor is delayed at any time in the commencement or progress of the Work by (1) an act or neglect of the Owner or Architect, of an employee of either, or of a Separate Contractor; (2) by changes ordered in the Work; (3) by labor disputes, fire, unusual delay in deliveries, unavoidable casualties, adverse weather conditions documented in accordance with Section 15.1.6.2, or other causes beyond the Contractor's control; (4) by delay authorized by the Owner pending mediation and binding dispute resolution; or (5) by other causes that the Contractor asserts, and the Architect determines, justify delay, then the Contract Time shall be extended for such reasonable time as the Architect may determine.

§ 8.3.2 Claims relating to time shall be made in accordance with applicable provisions of Article 15.

§ 8.3.3 This Section 8.3 does not preclude recovery of damages for delay by either party under other provisions of the Contract Documents.

## ARTICLE 9 PAYMENTS AND COMPLETION

### § 9.1 Contract Sum

§ 9.1.1 The Contract Sum is stated in the Agreement and, including authorized adjustments, is the total amount payable by the Owner to the Contractor for performance of the Work under the Contract Documents.

§ 9.1.2 If unit prices are stated in the Contract Documents or subsequently agreed upon, and if quantities originally contemplated are materially changed so that application of such unit prices to the actual quantities causes substantial inequity to the Owner or Contractor, the applicable unit prices shall be equitably adjusted.

### § 9.2 Schedule of Values

Where the Contract is based on a stipulated sum or Guaranteed Maximum Price, the Contractor shall submit a schedule of values to the Architect before the first Application for Payment, allocating the entire Contract Sum to the various portions of the Work. The schedule of values shall be prepared in the form, and supported by the data to substantiate its accuracy, required by the Architect. This schedule, unless objected to by the Architect, shall be used as a basis for reviewing the Contractor's Applications for Payment. Any changes to the schedule of values shall be submitted to the Architect and supported by such data to substantiate its accuracy as the Architect may require, and unless objected to by the Architect, shall be used as a basis for reviewing the Contractor's subsequent Applications for Payment.

### § 9.3 Applications for Payment

§ 9.3.1 At least ten days before the date established for each progress payment, the Contractor shall submit to the Architect an itemized Application for Payment prepared in accordance with the schedule of values, if required under Section 9.2, for completed portions of the Work. The application shall be notarized, if required, and supported by all data substantiating the Contractor's right to payment that the Owner or Architect require, such as copies of requisitions, and releases and waivers of liens from Subcontractors and suppliers, and shall reflect retainage if provided for in the Contract Documents.

§ 9.3.1.1 As provided in Section 7.3.9, such applications may include requests for payment on account of changes in the Work that have been properly authorized by Construction Change Directives, or by interim determinations of the Architect, but not yet included in Change Orders.



§ 9.3.1.2 Applications for Payment shall not include requests for payment for portions of the Work for which the Contractor does not intend to pay a Subcontractor or supplier, unless such Work has been performed by others whom the Contractor intends to pay.

§ 9.3.2 Unless otherwise provided in the Contract Documents, payments shall be made on account of materials and equipment delivered and suitably stored at the site for subsequent incorporation in the Work. If approved in advance by the Owner, payment may similarly be made for materials and equipment suitably stored off the site at a location agreed upon in writing. Payment for materials and equipment stored on or off the site shall be conditioned upon compliance by the Contractor with procedures satisfactory to the Owner to establish the Owner's title to such materials and equipment or otherwise protect the Owner's interest, and shall include the costs of applicable insurance, storage, and transportation to the site, for such materials and equipment stored off the site.

§ 9.3.3 The Contractor warrants that title to all Work covered by an Application for Payment will pass to the Owner no later than the time of payment. The Contractor further warrants that upon submittal of an Application for Payment all Work for which Certificates for Payment have been previously issued and payments received from the Owner shall, to the best of the Contractor's knowledge, information, and belief, be free and clear of liens, claims, security interests, or encumbrances, in favor of the Contractor, Subcontractors, suppliers, or other persons or entities that provided labor, materials, and equipment relating to the Work.

#### § 9.4 Certificates for Payment

§ 9.4.1 The Architect will, within seven days after receipt of the Contractor's Application for Payment, either (1) issue to the Owner a Certificate for Payment in the full amount of the Application for Payment, with a copy to the Contractor; or (2) issue to the Owner a Certificate for Payment for such amount as the Architect determines is properly due, and notify the Contractor and Owner of the Architect's reasons for withholding certification in part as provided in Section 9.5.1; or (3) withhold certification of the entire Application for Payment, and notify the Contractor and Owner of the Architect's reason for withholding certification in whole as provided in Section 9.5.1.

§ 9.4.2 The issuance of a Certificate for Payment will constitute a representation by the Architect to the Owner, based on the Architect's evaluation of the Work and the data in the Application for Payment, that, to the best of the Architect's knowledge, information, and belief, the Work has progressed to the point indicated, the quality of the Work is in accordance with the Contract Documents, and that the Contractor is entitled to payment in the amount certified. The foregoing representations are subject to an evaluation of the Work for conformance with the Contract Documents upon Substantial Completion, to results of subsequent tests and inspections, to correction of minor deviations from the Contract Documents prior to completion, and to specific qualifications expressed by the Architect. However, the issuance of a Certificate for Payment will not be a representation that the Architect has (1) made exhaustive or continuous on-site inspections to check the quality or quantity of the Work; (2) reviewed construction means, methods, techniques, sequences, or procedures; (3) reviewed copies of requisitions received from Subcontractors and suppliers and other data requested by the Owner to substantiate the Contractor's right to payment; or (4) made examination to ascertain how or for what purpose the Contractor has used money previously paid on account of the Contract Sum.

#### § 9.5 Decisions to Withhold Certification

§ 9.5.1 The Architect may withhold a Certificate for Payment in whole or in part, to the extent reasonably necessary to protect the Owner, if in the Architect's opinion the representations to the Owner required by Section 9.4.2 cannot be made. If the Architect is unable to certify payment in the amount of the Application, the Architect will notify the Contractor and Owner as provided in Section 9.4.1. If the Contractor and Architect cannot agree on a revised amount, the Architect will promptly issue a Certificate for Payment for the amount for which the Architect is able to make such representations to the Owner. The Architect may also withhold a Certificate for Payment or, because of subsequently discovered evidence, may nullify the whole or a part of a Certificate for Payment previously issued, to such extent as may be necessary in the Architect's opinion to protect the Owner from loss for which the Contractor is responsible, including loss resulting from acts and omissions described in Section 3.3.2, because of

- .1 defective Work not remedied;
- .2 third party claims filed or reasonable evidence indicating probable filing of such claims, unless security acceptable to the Owner is provided by the Contractor;
- .3 failure of the Contractor to make payments properly to Subcontractors or suppliers for labor, materials or equipment;

Init.

- .4 reasonable evidence that the Work cannot be completed for the unpaid balance of the Contract Sum;
- .5 damage to the Owner or a Separate Contractor;
- .6 reasonable evidence that the Work will not be completed within the Contract Time, and that the unpaid balance would not be adequate to cover actual or liquidated damages for the anticipated delay; or
- .7 repeated failure to carry out the Work in accordance with the Contract Documents.

§ 9.5.2 When either party disputes the Architect's decision regarding a Certificate for Payment under Section 9.5.1, in whole or in part, that party may submit a Claim in accordance with Article 15.

§ 9.5.3 When the reasons for withholding certification are removed, certification will be made for amounts previously withheld.

§ 9.5.4 If the Architect withholds certification for payment under Section 9.5.1.3, the Owner may, at its sole option, issue joint checks to the Contractor and to any Subcontractor or supplier to whom the Contractor failed to make payment for Work properly performed or material or equipment suitably delivered. If the Owner makes payments by joint check, the Owner shall notify the Architect and the Contractor shall reflect such payment on its next Application for Payment.

## § 9.6 Progress Payments

§ 9.6.1 After the Architect has issued a Certificate for Payment, the Owner shall make payment in the manner and within the time provided in the Contract Documents, and shall so notify the Architect.

§ 9.6.2 The Contractor shall pay each Subcontractor, no later than seven days after receipt of payment from the Owner, the amount to which the Subcontractor is entitled, reflecting percentages actually retained from payments to the Contractor on account of the Subcontractor's portion of the Work. The Contractor shall, by appropriate agreement with each Subcontractor, require each Subcontractor to make payments to Sub-subcontractors in a similar manner.

§ 9.6.3 The Architect will, on request, furnish to a Subcontractor, if practicable, information regarding percentages of completion or amounts applied for by the Contractor and action taken thereon by the Architect and Owner on account of portions of the Work done by such Subcontractor.

§ 9.6.4 The Owner has the right to request written evidence from the Contractor that the Contractor has properly paid Subcontractors and suppliers amounts paid by the Owner to the Contractor for subcontracted Work. If the Contractor fails to furnish such evidence within seven days, the Owner shall have the right to contact Subcontractors and suppliers to ascertain whether they have been properly paid. Neither the Owner nor Architect shall have an obligation to pay, or to see to the payment of money to, a Subcontractor or supplier, except as may otherwise be required by law.

§ 9.6.5 The Contractor's payments to suppliers shall be treated in a manner similar to that provided in Sections 9.6.2, 9.6.3 and 9.6.4.

§ 9.6.6 A Certificate for Payment, a progress payment, or partial or entire use or occupancy of the Project by the Owner shall not constitute acceptance of Work not in accordance with the Contract Documents.

§ 9.6.7 Unless the Contractor provides the Owner with a payment bond in the full penal sum of the Contract Sum, payments received by the Contractor for Work properly performed by Subcontractors or provided by suppliers shall be held by the Contractor for those Subcontractors or suppliers who performed Work or furnished materials, or both, under contract with the Contractor for which payment was made by the Owner. Nothing contained herein shall require money to be placed in a separate account and not commingled with money of the Contractor, create any fiduciary liability or tort liability on the part of the Contractor for breach of trust, or entitle any person or entity to an award of punitive damages against the Contractor for breach of the requirements of this provision.

§ 9.6.8 Provided the Owner has fulfilled its payment obligations under the Contract Documents, the Contractor shall defend and indemnify the Owner from all loss, liability, damage or expense, including reasonable attorney's fees and litigation expenses, arising out of any lien claim or other claim for payment by any Subcontractor or supplier of any tier. Upon receipt of notice of a lien claim or other claim for payment, the Owner shall notify the Contractor. If approved by the applicable court, when required, the Contractor may substitute a surety bond for the property against which the lien or other claim for payment has been asserted.

## § 9.7 Failure of Payment

If the Architect does not issue a Certificate for Payment, through no fault of the Contractor, within seven days after receipt of the Contractor's Application for Payment, or if the Owner does not pay the Contractor within seven days after the date established in the Contract Documents, the amount certified by the Architect or awarded by binding dispute resolution, then the Contractor may, upon seven additional days' notice to the Owner and Architect, stop the Work until payment of the amount owing has been received. The Contract Time shall be extended appropriately and the Contract Sum shall be increased by the amount of the Contractor's reasonable costs of shutdown, delay and start-up, plus interest as provided for in the Contract Documents.

## § 9.8 Substantial Completion

§ 9.8.1 Substantial Completion is the stage in the progress of the Work when the Work or designated portion thereof is sufficiently complete in accordance with the Contract Documents so that the Owner can occupy or utilize the Work for its intended use.

§ 9.8.2 When the Contractor considers that the Work, or a portion thereof which the Owner agrees to accept separately, is substantially complete, the Contractor shall prepare and submit to the Architect a comprehensive list of items to be completed or corrected prior to final payment. Failure to include an item on such list does not alter the responsibility of the Contractor to complete all Work in accordance with the Contract Documents.

§ 9.8.3 Upon receipt of the Contractor's list, the Architect will make an inspection to determine whether the Work or designated portion thereof is substantially complete. If the Architect's inspection discloses any item, whether or not included on the Contractor's list, which is not sufficiently complete in accordance with the Contract Documents so that the Owner can occupy or utilize the Work or designated portion thereof for its intended use, the Contractor shall, before issuance of the Certificate of Substantial Completion, complete or correct such item upon notification by the Architect. In such case, the Contractor shall then submit a request for another inspection by the Architect to determine Substantial Completion.

§ 9.8.4 When the Work or designated portion thereof is substantially complete, the Architect will prepare a Certificate of Substantial Completion that shall establish the date of Substantial Completion; establish responsibilities of the Owner and Contractor for security, maintenance, heat, utilities, damage to the Work and insurance; and fix the time within which the Contractor shall finish all items on the list accompanying the Certificate. Warranties required by the Contract Documents shall commence on the date of Substantial Completion of the Work or designated portion thereof unless otherwise provided in the Certificate of Substantial Completion.

§ 9.8.5 The Certificate of Substantial Completion shall be submitted to the Owner and Contractor for their written acceptance of responsibilities assigned to them in the Certificate. Upon such acceptance, and consent of surety if any, the Owner shall make payment of retainage applying to the Work or designated portion thereof. Such payment shall be adjusted for Work that is incomplete or not in accordance with the requirements of the Contract Documents.

## § 9.9 Partial Occupancy or Use

§ 9.9.1 The Owner may occupy or use any completed or partially completed portion of the Work at any stage when such portion is designated by separate agreement with the Contractor, provided such occupancy or use is consented to by the insurer and authorized by public authorities having jurisdiction over the Project. Such partial occupancy or use may commence whether or not the portion is substantially complete, provided the Owner and Contractor have accepted in writing the responsibilities assigned to each of them for payments, retainage, if any, security, maintenance, heat, utilities, damage to the Work and insurance, and have agreed in writing concerning the period for correction of the Work and commencement of warranties required by the Contract Documents. When the Contractor considers a portion substantially complete, the Contractor shall prepare and submit a list to the Architect as provided under Section 9.8.2. Consent of the Contractor to partial occupancy or use shall not be unreasonably withheld. The stage of the progress of the Work shall be determined by written agreement between the Owner and Contractor or, if no agreement is reached, by decision of the Architect.

§ 9.9.2 Immediately prior to such partial occupancy or use, the Owner, Contractor, and Architect shall jointly inspect the area to be occupied or portion of the Work to be used in order to determine and record the condition of the Work.



§ 9.9.3 Unless otherwise agreed upon, partial occupancy or use of a portion or portions of the Work shall not constitute acceptance of Work not complying with the requirements of the Contract Documents.

#### § 9.10 Final Completion and Final Payment

§ 9.10.1 Upon receipt of the Contractor's notice that the Work is ready for final inspection and acceptance and upon receipt of a final Application for Payment, the Architect will promptly make such inspection. When the Architect finds the Work acceptable under the Contract Documents and the Contract fully performed, the Architect will promptly issue a final Certificate for Payment stating that to the best of the Architect's knowledge, information and belief, and on the basis of the Architect's on-site visits and inspections, the Work has been completed in accordance with the Contract Documents and that the entire balance found to be due the Contractor and noted in the final Certificate is due and payable. The Architect's final Certificate for Payment will constitute a further representation that conditions listed in Section 9.10.2 as precedent to the Contractor's being entitled to final payment have been fulfilled.

§ 9.10.2 Neither final payment nor any remaining retained percentage shall become due until the Contractor submits to the Architect (1) an affidavit that payrolls, bills for materials and equipment, and other indebtedness connected with the Work for which the Owner or the Owner's property might be responsible or encumbered (less amounts withheld by Owner) have been paid or otherwise satisfied, (2) a certificate evidencing that insurance required by the Contract Documents to remain in force after final payment is currently in effect, (3) a written statement that the Contractor knows of no reason that the insurance will not be renewable to cover the period required by the Contract Documents, (4) consent of surety, if any, to final payment, (5) documentation of any special warranties, such as manufacturers' warranties or specific Subcontractor warranties, and (6) if required by the Owner, other data establishing payment or satisfaction of obligations, such as receipts and releases and waivers of liens, claims, security interests, or encumbrances arising out of the Contract, to the extent and in such form as may be designated by the Owner. If a Subcontractor refuses to furnish a release or waiver required by the Owner, the Contractor may furnish a bond satisfactory to the Owner to indemnify the Owner against such lien, claim, security interest, or encumbrance. If a lien, claim, security interest, or encumbrance remains unsatisfied after payments are made, the Contractor shall refund to the Owner all money that the Owner may be compelled to pay in discharging the lien, claim, security interest, or encumbrance, including all costs and reasonable attorneys' fees.

§ 9.10.3 If, after Substantial Completion of the Work, final completion thereof is materially delayed through no fault of the Contractor or by issuance of Change Orders affecting final completion, and the Architect so confirms, the Owner shall, upon application by the Contractor and certification by the Architect, and without terminating the Contract, make payment of the balance due for that portion of the Work fully completed, corrected, and accepted. If the remaining balance for Work not fully completed or corrected is less than retainage stipulated in the Contract Documents, and if bonds have been furnished, the written consent of the surety to payment of the balance due for that portion of the Work fully completed and accepted shall be submitted by the Contractor to the Architect prior to certification of such payment. Such payment shall be made under terms and conditions governing final payment, except that it shall not constitute a waiver of Claims.

§ 9.10.4 The making of final payment shall constitute a waiver of Claims by the Owner except those arising from

- .1 liens, Claims, security interests, or encumbrances arising out of the Contract and unsettled;
- .2 failure of the Work to comply with the requirements of the Contract Documents;
- .3 terms of special warranties required by the Contract Documents; or
- .4 audits performed by the Owner, if permitted by the Contract Documents, after final payment.

§ 9.10.5 Acceptance of final payment by the Contractor, a Subcontractor, or a supplier, shall constitute a waiver of claims by that payee except those previously made in writing and identified by that payee as unsettled at the time of final Application for Payment.

### ARTICLE 10 PROTECTION OF PERSONS AND PROPERTY

#### § 10.1 Safety Precautions and Programs

The Contractor shall be responsible for initiating, maintaining, and supervising all safety precautions and programs in connection with the performance of the Contract.

#### § 10.2 Safety of Persons and Property

§ 10.2.1 The Contractor shall take reasonable precautions for safety of, and shall provide reasonable protection to prevent damage, injury, or loss to

Init.

/



- .1 employees on the Work and other persons who may be affected thereby;
- .2 the Work and materials and equipment to be incorporated therein, whether in storage on or off the site, under care, custody, or control of the Contractor, a Subcontractor, or a Sub-subcontractor; and
- .3 other property at the site or adjacent thereto, such as trees, shrubs, lawns, walks, pavements, roadways, structures, and utilities not designated for removal, relocation, or replacement in the course of construction.

§ 10.2.2 The Contractor shall comply with, and give notices required by applicable laws, statutes, ordinances, codes, rules and regulations, and lawful orders of public authorities, bearing on safety of persons or property or their protection from damage, injury, or loss.

§ 10.2.3 The Contractor shall implement, erect, and maintain, as required by existing conditions and performance of the Contract, reasonable safeguards for safety and protection, including posting danger signs and other warnings against hazards; promulgating safety regulations; and notifying the owners and users of adjacent sites and utilities of the safeguards.

§ 10.2.4 When use or storage of explosives or other hazardous materials or equipment, or unusual methods are necessary for execution of the Work, the Contractor shall exercise utmost care and carry on such activities under supervision of properly qualified personnel.

§ 10.2.5 The Contractor shall promptly remedy damage and loss (other than damage or loss insured under property insurance required by the Contract Documents) to property referred to in Sections 10.2.1.2 and 10.2.1.3 caused in whole or in part by the Contractor, a Subcontractor, a Sub-subcontractor, or anyone directly or indirectly employed by any of them, or by anyone for whose acts they may be liable and for which the Contractor is responsible under Sections 10.2.1.2 and 10.2.1.3. The Contractor may make a Claim for the cost to remedy the damage or loss to the extent such damage or loss is attributable to acts or omissions of the Owner or Architect or anyone directly or indirectly employed by either of them, or by anyone for whose acts either of them may be liable, and not attributable to the fault or negligence of the Contractor. The foregoing obligations of the Contractor are in addition to the Contractor's obligations under Section 3.18.

§ 10.2.6 The Contractor shall designate a responsible member of the Contractor's organization at the site whose duty shall be the prevention of accidents. This person shall be the Contractor's superintendent unless otherwise designated by the Contractor in writing to the Owner and Architect.

§ 10.2.7 The Contractor shall not permit any part of the construction or site to be loaded so as to cause damage or create an unsafe condition.

#### § 10.2.8 Injury or Damage to Person or Property

If either party suffers injury or damage to person or property because of an act or omission of the other party, or of others for whose acts such party is legally responsible, notice of the injury or damage, whether or not insured, shall be given to the other party within a reasonable time not exceeding 21 days after discovery. The notice shall provide sufficient detail to enable the other party to investigate the matter.

#### § 10.3 Hazardous Materials and Substances

§ 10.3.1 The Contractor is responsible for compliance with any requirements included in the Contract Documents regarding hazardous materials or substances. If the Contractor encounters a hazardous material or substance not addressed in the Contract Documents and if reasonable precautions will be inadequate to prevent foreseeable bodily injury or death to persons resulting from a material or substance, including but not limited to asbestos or polychlorinated biphenyl (PCB), encountered on the site by the Contractor, the Contractor shall, upon recognizing the condition, immediately stop Work in the affected area and notify the Owner and Architect of the condition.

§ 10.3.2 Upon receipt of the Contractor's notice, the Owner shall obtain the services of a licensed laboratory to verify the presence or absence of the material or substance reported by the Contractor and, in the event such material or substance is found to be present, to cause it to be rendered harmless. Unless otherwise required by the Contract Documents, the Owner shall furnish in writing to the Contractor and Architect the names and qualifications of persons or entities who are to perform tests verifying the presence or absence of the material or substance or who are to perform the task of removal or safe containment of the material or substance. The Contractor and the Architect will

promptly reply to the Owner in writing stating whether or not either has reasonable objection to the persons or entities proposed by the Owner. If either the Contractor or Architect has an objection to a person or entity proposed by the Owner, the Owner shall propose another to whom the Contractor and the Architect have no reasonable objection. When the material or substance has been rendered harmless, Work in the affected area shall resume upon written agreement of the Owner and Contractor. By Change Order, the Contract Time shall be extended appropriately and the Contract Sum shall be increased by the amount of the Contractor's reasonable additional costs of shutdown, delay, and start-up.

**§ 10.3.3** To the fullest extent permitted by law, the Owner shall indemnify and hold harmless the Contractor, Subcontractors, Architect, Architect's consultants, and agents and employees of any of them from and against claims, damages, losses, and expenses, including but not limited to attorneys' fees, arising out of or resulting from performance of the Work in the affected area if in fact the material or substance presents the risk of bodily injury or death as described in Section 10.3.1 and has not been rendered harmless, provided that such claim, damage, loss, or expense is attributable to bodily injury, sickness, disease or death, or to injury to or destruction of tangible property (other than the Work itself), except to the extent that such damage, loss, or expense is due to the fault or negligence of the party seeking indemnity.

**§ 10.3.4** The Owner shall not be responsible under this Section 10.3 for hazardous materials or substances the Contractor brings to the site unless such materials or substances are required by the Contract Documents. The Owner shall be responsible for hazardous materials or substances required by the Contract Documents, except to the extent of the Contractor's fault or negligence in the use and handling of such materials or substances.

**§ 10.3.5** The Contractor shall reimburse the Owner for the cost and expense the Owner incurs (1) for remediation of hazardous materials or substances the Contractor brings to the site and negligently handles, or (2) where the Contractor fails to perform its obligations under Section 10.3.1, except to the extent that the cost and expense are due to the Owner's fault or negligence.

**§ 10.3.6** If, without negligence on the part of the Contractor, the Contractor is held liable by a government agency for the cost of remediation of a hazardous material or substance solely by reason of performing Work as required by the Contract Documents, the Owner shall reimburse the Contractor for all cost and expense thereby incurred.

#### **§ 10.4 Emergencies**

In an emergency affecting safety of persons or property, the Contractor shall act, at the Contractor's discretion, to prevent threatened damage, injury, or loss. Additional compensation or extension of time claimed by the Contractor on account of an emergency shall be determined as provided in Article 15 and Article 7.

### **ARTICLE 11 INSURANCE AND BONDS**

#### **§ 11.1 Contractor's Insurance and Bonds**

**§ 11.1.1** The Contractor shall purchase and maintain insurance of the types and limits of liability, containing the endorsements, and subject to the terms and conditions, as described in the Agreement or elsewhere in the Contract Documents. The Contractor shall purchase and maintain the required insurance from an insurance company or insurance companies lawfully authorized to issue insurance in the jurisdiction where the Project is located. The Owner, Architect, and Architect's consultants shall be named as additional insureds under the Contractor's commercial general liability policy or as otherwise described in the Contract Documents.

**§ 11.1.2** The Contractor shall provide surety bonds of the types, for such penal sums, and subject to such terms and conditions as required by the Contract Documents. The Contractor shall purchase and maintain the required bonds from a company or companies lawfully authorized to issue surety bonds in the jurisdiction where the Project is located.

**§ 11.1.3** Upon the request of any person or entity appearing to be a potential beneficiary of bonds covering payment of obligations arising under the Contract, the Contractor shall promptly furnish a copy of the bonds or shall authorize a copy to be furnished.

**§ 11.1.4 Notice of Cancellation or Expiration of Contractor's Required Insurance.** Within three (3) business days of the date the Contractor becomes aware of an impending or actual cancellation or expiration of any insurance required by the Contract Documents, the Contractor shall provide notice to the Owner of such impending or actual cancellation or expiration. Upon receipt of notice from the Contractor, the Owner shall, unless the lapse in coverage arises from an act

or omission of the Owner, have the right to stop the Work until the lapse in coverage has been cured by the procurement of replacement coverage by the Contractor. The furnishing of notice by the Contractor shall not relieve the Contractor of any contractual obligation to provide any required coverage.

## § 11.2 Owner's Insurance

§ 11.2.1 The Owner shall purchase and maintain insurance of the types and limits of liability, containing the endorsements, and subject to the terms and conditions, as described in the Agreement or elsewhere in the Contract Documents. The Owner shall purchase and maintain the required insurance from an insurance company or insurance companies lawfully authorized to issue insurance in the jurisdiction where the Project is located.

§ 11.2.2 **Failure to Purchase Required Property Insurance.** If the Owner fails to purchase and maintain the required property insurance, with all of the coverages and in the amounts described in the Agreement or elsewhere in the Contract Documents, the Owner shall inform the Contractor in writing prior to commencement of the Work. Upon receipt of notice from the Owner, the Contractor may delay commencement of the Work and may obtain insurance that will protect the interests of the Contractor, Subcontractors, and Sub-Subcontractors in the Work. When the failure to provide coverage has been cured or resolved, the Contract Sum and Contract Time shall be equitably adjusted. In the event the Owner fails to procure coverage, the Owner waives all rights against the Contractor, Subcontractors, and Sub-subcontractors to the extent the loss to the Owner would have been covered by the insurance to have been procured by the Owner. The cost of the insurance shall be charged to the Owner by a Change Order. If the Owner does not provide written notice, and the Contractor is damaged by the failure or neglect of the Owner to purchase or maintain the required insurance, the Owner shall reimburse the Contractor for all reasonable costs and damages attributable thereto.

§ 11.2.3 **Notice of Cancellation or Expiration of Owner's Required Property Insurance.** Within three (3) business days of the date the Owner becomes aware of an impending or actual cancellation or expiration of any property insurance required by the Contract Documents, the Owner shall provide notice to the Contractor of such impending or actual cancellation or expiration. Unless the lapse in coverage arises from an act or omission of the Contractor: (1) the Contractor, upon receipt of notice from the Owner, shall have the right to stop the Work until the lapse in coverage has been cured by the procurement of replacement coverage by either the Owner or the Contractor; (2) the Contract Time and Contract Sum shall be equitably adjusted; and (3) the Owner waives all rights against the Contractor, Subcontractors, and Sub-subcontractors to the extent any loss to the Owner would have been covered by the insurance had it not expired or been cancelled. If the Contractor purchases replacement coverage, the cost of the insurance shall be charged to the Owner by an appropriate Change Order. The furnishing of notice by the Owner shall not relieve the Owner of any contractual obligation to provide required insurance.

## § 11.3 Waivers of Subrogation

§ 11.3.1 The Owner and Contractor waive all rights against (1) each other and any of their subcontractors, sub-subcontractors, agents, and employees, each of the other; (2) the Architect and Architect's consultants; and (3) Separate Contractors, if any, and any of their subcontractors, sub-subcontractors, agents, and employees, for damages caused by fire, or other causes of loss, to the extent those losses are covered by property insurance required by the Agreement or other property insurance applicable to the Project, except such rights as they have to proceeds of such insurance. The Owner or Contractor, as appropriate, shall require similar written waivers in favor of the individuals and entities identified above from the Architect, Architect's consultants, Separate Contractors, subcontractors, and sub-subcontractors. The policies of insurance purchased and maintained by each person or entity agreeing to waive claims pursuant to this section 11.3.1 shall not prohibit this waiver of subrogation. This waiver of subrogation shall be effective as to a person or entity (1) even though that person or entity would otherwise have a duty of indemnification, contractual or otherwise, (2) even though that person or entity did not pay the insurance premium directly or indirectly, or (3) whether or not the person or entity had an insurable interest in the damaged property.

§ 11.3.2 If during the Project construction period the Owner insures properties, real or personal or both, at or adjacent to the site by property insurance under policies separate from those insuring the Project, or if after final payment property insurance is to be provided on the completed Project through a policy or policies other than those insuring the Project during the construction period, to the extent permissible by such policies, the Owner waives all rights in accordance with the terms of Section 11.3.1 for damages caused by fire or other causes of loss covered by this separate property insurance.

## § 11.4 Loss of Use, Business Interruption, and Delay in Completion Insurance

Init.

**AIA Document A201® – 2017.** Copyright © 1911, 1915, 1918, 1925, 1937, 1951, 1958, 1961, 1963, 1966, 1970, 1976, 1987, 1997, 2007 and 2017 by The American Institute of Architects. All rights reserved. The "American Institute of Architects," "AIA," the AIA Logo, "A201," and "AIA Contract Documents" are registered trademarks and may not be used without permission. This document was produced by AIA software at 08:02:46 ET on 05/19/2021 under Order No.0514486010 which expires on 09/11/2021, is not for resale, is licensed for one-time use only, and may only be used in accordance with the AIA Contract Documents® Terms of Service. To report copyright violations, e-mail [copyright@aia.org](mailto:copyright@aia.org).

**User Notes:**

(1681408580)



The Owner, at the Owner's option, may purchase and maintain insurance that will protect the Owner against loss of use of the Owner's property, or the inability to conduct normal operations, due to fire or other causes of loss. The Owner waives all rights of action against the Contractor and Architect for loss of use of the Owner's property, due to fire or other hazards however caused.

#### **§11.5 Adjustment and Settlement of Insured Loss**

**§ 11.5.1** A loss insured under the property insurance required by the Agreement shall be adjusted by the Owner as fiduciary and made payable to the Owner as fiduciary for the insureds, as their interests may appear, subject to requirements of any applicable mortgagee clause and of Section 11.5.2. The Owner shall pay the Architect and Contractor their just shares of insurance proceeds received by the Owner, and by appropriate agreements the Architect and Contractor shall make payments to their consultants and Subcontractors in similar manner.

**§ 11.5.2** Prior to settlement of an insured loss, the Owner shall notify the Contractor of the terms of the proposed settlement as well as the proposed allocation of the insurance proceeds. The Contractor shall have 14 days from receipt of notice to object to the proposed settlement or allocation of the proceeds. If the Contractor does not object, the Owner shall settle the loss and the Contractor shall be bound by the settlement and allocation. Upon receipt, the Owner shall deposit the insurance proceeds in a separate account and make the appropriate distributions. Thereafter, if no other agreement is made or the Owner does not terminate the Contract for convenience, the Owner and Contractor shall execute a Change Order for reconstruction of the damaged or destroyed Work in the amount allocated for that purpose. If the Contractor timely objects to either the terms of the proposed settlement or the allocation of the proceeds, the Owner may proceed to settle the insured loss, and any dispute between the Owner and Contractor arising out of the settlement or allocation of the proceeds shall be resolved pursuant to Article 15. Pending resolution of any dispute, the Owner may issue a Construction Change Directive for the reconstruction of the damaged or destroyed Work.

### **ARTICLE 12 UNCOVERING AND CORRECTION OF WORK**

#### **§ 12.1 Uncovering of Work**

**§ 12.1.1** If a portion of the Work is covered contrary to the Architect's request or to requirements specifically expressed in the Contract Documents, it must, if requested in writing by the Architect, be uncovered for the Architect's examination and be replaced at the Contractor's expense without change in the Contract Time.

**§ 12.1.2** If a portion of the Work has been covered that the Architect has not specifically requested to examine prior to its being covered, the Architect may request to see such Work and it shall be uncovered by the Contractor. If such Work is in accordance with the Contract Documents, the Contractor shall be entitled to an equitable adjustment to the Contract Sum and Contract Time as may be appropriate. If such Work is not in accordance with the Contract Documents, the costs of uncovering the Work, and the cost of correction, shall be at the Contractor's expense.

#### **§ 12.2 Correction of Work**

##### **§ 12.2.1 Before Substantial Completion**

The Contractor shall promptly correct Work rejected by the Architect or failing to conform to the requirements of the Contract Documents, discovered before Substantial Completion and whether or not fabricated, installed or completed. Costs of correcting such rejected Work, including additional testing and inspections, the cost of uncovering and replacement, and compensation for the Architect's services and expenses made necessary thereby, shall be at the Contractor's expense.

##### **§ 12.2.2 After Substantial Completion**

**§ 12.2.2.1** In addition to the Contractor's obligations under Section 3.5, if, within one year after the date of Substantial Completion of the Work or designated portion thereof or after the date for commencement of warranties established under Section 9.9.1, or by terms of any applicable special warranty required by the Contract Documents, any of the Work is found to be not in accordance with the requirements of the Contract Documents, the Contractor shall correct it promptly after receipt of notice from the Owner to do so, unless the Owner has previously given the Contractor a written acceptance of such condition. The Owner shall give such notice promptly after discovery of the condition. During the one-year period for correction of Work, if the Owner fails to notify the Contractor and give the Contractor an opportunity to make the correction, the Owner waives the rights to require correction by the Contractor and to make a claim for breach of warranty. If the Contractor fails to correct nonconforming Work within a reasonable time during that period after receipt of notice from the Owner or Architect, the Owner may correct it in accordance with Section 2.5.

§ 12.2.2.2 The one-year period for correction of Work shall be extended with respect to portions of Work first performed after Substantial Completion by the period of time between Substantial Completion and the actual completion of that portion of the Work.

§ 12.2.2.3 The one-year period for correction of Work shall not be extended by corrective Work performed by the Contractor pursuant to this Section 12.2.

§ 12.2.3 The Contractor shall remove from the site portions of the Work that are not in accordance with the requirements of the Contract Documents and are neither corrected by the Contractor nor accepted by the Owner.

§ 12.2.4 The Contractor shall bear the cost of correcting destroyed or damaged construction of the Owner or Separate Contractors, whether completed or partially completed, caused by the Contractor's correction or removal of Work that is not in accordance with the requirements of the Contract Documents.

§ 12.2.5 Nothing contained in this Section 12.2 shall be construed to establish a period of limitation with respect to other obligations the Contractor has under the Contract Documents. Establishment of the one-year period for correction of Work as described in Section 12.2.2 relates only to the specific obligation of the Contractor to correct the Work, and has no relationship to the time within which the obligation to comply with the Contract Documents may be sought to be enforced, nor to the time within which proceedings may be commenced to establish the Contractor's liability with respect to the Contractor's obligations other than specifically to correct the Work.

### § 12.3 Acceptance of Nonconforming Work

If the Owner prefers to accept Work that is not in accordance with the requirements of the Contract Documents, the Owner may do so instead of requiring its removal and correction, in which case the Contract Sum will be reduced as appropriate and equitable. Such adjustment shall be effected whether or not final payment has been made.

## ARTICLE 13 MISCELLANEOUS PROVISIONS

### § 13.1 Governing Law

The Contract shall be governed by the law of the place where the Project is located, excluding that jurisdiction's choice of law rules. If the parties have selected arbitration as the method of binding dispute resolution, the Federal Arbitration Act shall govern Section 15.4.

### § 13.2 Successors and Assigns

§ 13.2.1 The Owner and Contractor respectively bind themselves, their partners, successors, assigns, and legal representatives to covenants, agreements, and obligations contained in the Contract Documents. Except as provided in Section 13.2.2, neither party to the Contract shall assign the Contract as a whole without written consent of the other. If either party attempts to make an assignment without such consent, that party shall nevertheless remain legally responsible for all obligations under the Contract.

§ 13.2.2 The Owner may, without consent of the Contractor, assign the Contract to a lender providing construction financing for the Project, if the lender assumes the Owner's rights and obligations under the Contract Documents. The Contractor shall execute all consents reasonably required to facilitate the assignment.

### § 13.3 Rights and Remedies

§ 13.3.1 Duties and obligations imposed by the Contract Documents and rights and remedies available thereunder shall be in addition to and not a limitation of duties, obligations, rights, and remedies otherwise imposed or available by law.

§ 13.3.2 No action or failure to act by the Owner, Architect, or Contractor shall constitute a waiver of a right or duty afforded them under the Contract, nor shall such action or failure to act constitute approval of or acquiescence in a breach thereunder, except as may be specifically agreed upon in writing.

### § 13.4 Tests and Inspections

§ 13.4.1 Tests, inspections, and approvals of portions of the Work shall be made as required by the Contract Documents and by applicable laws, statutes, ordinances, codes, rules, and regulations or lawful orders of public authorities. Unless otherwise provided, the Contractor shall make arrangements for such tests, inspections, and

approvals with an independent testing laboratory or entity acceptable to the Owner, or with the appropriate public authority, and shall bear all related costs of tests, inspections, and approvals. The Contractor shall give the Architect timely notice of when and where tests and inspections are to be made so that the Architect may be present for such procedures. The Owner shall bear costs of tests, inspections, or approvals that do not become requirements until after bids are received or negotiations concluded. The Owner shall directly arrange and pay for tests, inspections, or approvals where building codes or applicable laws or regulations so require.

§ 13.4.2 If the Architect, Owner, or public authorities having jurisdiction determine that portions of the Work require additional testing, inspection, or approval not included under Section 13.4.1, the Architect will, upon written authorization from the Owner, instruct the Contractor to make arrangements for such additional testing, inspection, or approval, by an entity acceptable to the Owner, and the Contractor shall give timely notice to the Architect of when and where tests and inspections are to be made so that the Architect may be present for such procedures. Such costs, except as provided in Section 13.4.3, shall be at the Owner's expense.

§ 13.4.3 If procedures for testing, inspection, or approval under Sections 13.4.1 and 13.4.2 reveal failure of the portions of the Work to comply with requirements established by the Contract Documents, all costs made necessary by such failure, including those of repeated procedures and compensation for the Architect's services and expenses, shall be at the Contractor's expense.

§ 13.4.4 Required certificates of testing, inspection, or approval shall, unless otherwise required by the Contract Documents, be secured by the Contractor and promptly delivered to the Architect.

§ 13.4.5 If the Architect is to observe tests, inspections, or approvals required by the Contract Documents, the Architect will do so promptly and, where practicable, at the normal place of testing.

§ 13.4.6 Tests or inspections conducted pursuant to the Contract Documents shall be made promptly to avoid unreasonable delay in the Work.

### § 13.5 Interest

Payments due and unpaid under the Contract Documents shall bear interest from the date payment is due at the rate the parties agree upon in writing or, in the absence thereof, at the legal rate prevailing from time to time at the place where the Project is located.

## ARTICLE 14 TERMINATION OR SUSPENSION OF THE CONTRACT

### § 14.1 Termination by the Contractor

§ 14.1.1 The Contractor may terminate the Contract if the Work is stopped for a period of 30 consecutive days through no act or fault of the Contractor, a Subcontractor, a Sub-subcontractor, their agents or employees, or any other persons or entities performing portions of the Work, for any of the following reasons:

- .1 Issuance of an order of a court or other public authority having jurisdiction that requires all Work to be stopped;
- .2 An act of government, such as a declaration of national emergency, that requires all Work to be stopped;
- .3 Because the Architect has not issued a Certificate for Payment and has not notified the Contractor of the reason for withholding certification as provided in Section 9.4.1, or because the Owner has not made payment on a Certificate for Payment within the time stated in the Contract Documents; or
- .4 The Owner has failed to furnish to the Contractor reasonable evidence as required by Section 2.2.

§ 14.1.2 The Contractor may terminate the Contract if, through no act or fault of the Contractor, a Subcontractor, a Sub-subcontractor, their agents or employees, or any other persons or entities performing portions of the Work, repeated suspensions, delays, or interruptions of the entire Work by the Owner as described in Section 14.3, constitute in the aggregate more than 100 percent of the total number of days scheduled for completion, or 120 days in any 365-day period, whichever is less.

§ 14.1.3 If one of the reasons described in Section 14.1.1 or 14.1.2 exists, the Contractor may, upon seven days' notice to the Owner and Architect, terminate the Contract and recover from the Owner payment for Work executed, as well as reasonable overhead and profit on Work not executed, and costs incurred by reason of such termination.

§ 14.1.4 If the Work is stopped for a period of 60 consecutive days through no act or fault of the Contractor, a Subcontractor, a Sub-subcontractor, or their agents or employees or any other persons or entities performing portions of the Work because the Owner has repeatedly failed to fulfill the Owner's obligations under the Contract Documents with respect to matters important to the progress of the Work, the Contractor may, upon seven additional days' notice to the Owner and the Architect, terminate the Contract and recover from the Owner as provided in Section 14.1.3.

#### § 14.2 Termination by the Owner for Cause

§ 14.2.1 The Owner may terminate the Contract if the Contractor

- .1 repeatedly refuses or fails to supply enough properly skilled workers or proper materials;
- .2 fails to make payment to Subcontractors or suppliers in accordance with the respective agreements between the Contractor and the Subcontractors or suppliers;
- .3 repeatedly disregards applicable laws, statutes, ordinances, codes, rules and regulations, or lawful orders of a public authority; or
- .4 otherwise is guilty of substantial breach of a provision of the Contract Documents.

§ 14.2.2 When any of the reasons described in Section 14.2.1 exist, and upon certification by the Architect that sufficient cause exists to justify such action, the Owner may, without prejudice to any other rights or remedies of the Owner and after giving the Contractor and the Contractor's surety, if any, seven days' notice, terminate employment of the Contractor and may, subject to any prior rights of the surety:

- .1 Exclude the Contractor from the site and take possession of all materials, equipment, tools, and construction equipment and machinery thereon owned by the Contractor;
- .2 Accept assignment of subcontracts pursuant to Section 5.4; and
- .3 Finish the Work by whatever reasonable method the Owner may deem expedient. Upon written request of the Contractor, the Owner shall furnish to the Contractor a detailed accounting of the costs incurred by the Owner in finishing the Work.

§ 14.2.3 When the Owner terminates the Contract for one of the reasons stated in Section 14.2.1, the Contractor shall not be entitled to receive further payment until the Work is finished.

§ 14.2.4 If the unpaid balance of the Contract Sum exceeds costs of finishing the Work, including compensation for the Architect's services and expenses made necessary thereby, and other damages incurred by the Owner and not expressly waived, such excess shall be paid to the Contractor. If such costs and damages exceed the unpaid balance, the Contractor shall pay the difference to the Owner. The amount to be paid to the Contractor or Owner, as the case may be, shall be certified by the Initial Decision Maker, upon application, and this obligation for payment shall survive termination of the Contract.

#### § 14.3 Suspension by the Owner for Convenience

§ 14.3.1 The Owner may, without cause, order the Contractor in writing to suspend, delay or interrupt the Work, in whole or in part for such period of time as the Owner may determine.

§ 14.3.2 The Contract Sum and Contract Time shall be adjusted for increases in the cost and time caused by suspension, delay, or interruption under Section 14.3.1. Adjustment of the Contract Sum shall include profit. No adjustment shall be made to the extent

- .1 that performance is, was, or would have been, so suspended, delayed, or interrupted, by another cause for which the Contractor is responsible; or
- .2 that an equitable adjustment is made or denied under another provision of the Contract.

#### § 14.4 Termination by the Owner for Convenience

§ 14.4.1 The Owner may, at any time, terminate the Contract for the Owner's convenience and without cause.

§ 14.4.2 Upon receipt of notice from the Owner of such termination for the Owner's convenience, the Contractor shall

- .1 cease operations as directed by the Owner in the notice;
- .2 take actions necessary, or that the Owner may direct, for the protection and preservation of the Work; and
- .3 except for Work directed to be performed prior to the effective date of termination stated in the notice, terminate all existing subcontracts and purchase orders and enter into no further subcontracts and purchase orders.



§ 14.4.3 In case of such termination for the Owner's convenience, the Owner shall pay the Contractor for Work properly executed; costs incurred by reason of the termination, including costs attributable to termination of Subcontracts; and the termination fee, if any, set forth in the Agreement.

## ARTICLE 15 CLAIMS AND DISPUTES

### § 15.1 Claims

#### § 15.1.1 Definition

A Claim is a demand or assertion by one of the parties seeking, as a matter of right, payment of money, a change in the Contract Time, or other relief with respect to the terms of the Contract. The term "Claim" also includes other disputes and matters in question between the Owner and Contractor arising out of or relating to the Contract. The responsibility to substantiate Claims shall rest with the party making the Claim. This Section 15.1.1 does not require the Owner to file a Claim in order to impose liquidated damages in accordance with the Contract Documents.

#### § 15.1.2 Time Limits on Claims

The Owner and Contractor shall commence all Claims and causes of action against the other and arising out of or related to the Contract, whether in contract, tort, breach of warranty or otherwise, in accordance with the requirements of the binding dispute resolution method selected in the Agreement and within the period specified by applicable law, but in any case not more than 10 years after the date of Substantial Completion of the Work. The Owner and Contractor waive all Claims and causes of action not commenced in accordance with this Section 15.1.2.

#### § 15.1.3 Notice of Claims

§ 15.1.3.1 Claims by either the Owner or Contractor, where the condition giving rise to the Claim is first discovered prior to expiration of the period for correction of the Work set forth in Section 12.2.2, shall be initiated by notice to the other party and to the Initial Decision Maker with a copy sent to the Architect, if the Architect is not serving as the Initial Decision Maker. Claims by either party under this Section 15.1.3.1 shall be initiated within 21 days after occurrence of the event giving rise to such Claim or within 21 days after the claimant first recognizes the condition giving rise to the Claim, whichever is later.

§ 15.1.3.2 Claims by either the Owner or Contractor, where the condition giving rise to the Claim is first discovered after expiration of the period for correction of the Work set forth in Section 12.2.2, shall be initiated by notice to the other party. In such event, no decision by the Initial Decision Maker is required.

#### § 15.1.4 Continuing Contract Performance

§ 15.1.4.1 Pending final resolution of a Claim, except as otherwise agreed in writing or as provided in Section 9.7 and Article 14, the Contractor shall proceed diligently with performance of the Contract and the Owner shall continue to make payments in accordance with the Contract Documents.

§ 15.1.4.2 The Contract Sum and Contract Time shall be adjusted in accordance with the Initial Decision Maker's decision, subject to the right of either party to proceed in accordance with this Article 15. The Architect will issue Certificates for Payment in accordance with the decision of the Initial Decision Maker.

#### § 15.1.5 Claims for Additional Cost

If the Contractor wishes to make a Claim for an increase in the Contract Sum, notice as provided in Section 15.1.3 shall be given before proceeding to execute the portion of the Work that is the subject of the Claim. Prior notice is not required for Claims relating to an emergency endangering life or property arising under Section 10.4.

#### § 15.1.6 Claims for Additional Time

§ 15.1.6.1 If the Contractor wishes to make a Claim for an increase in the Contract Time, notice as provided in Section 15.1.3 shall be given. The Contractor's Claim shall include an estimate of cost and of probable effect of delay on progress of the Work. In the case of a continuing delay, only one Claim is necessary.

§ 15.1.6.2 If adverse weather conditions are the basis for a Claim for additional time, such Claim shall be documented by data substantiating that weather conditions were abnormal for the period of time, could not have been reasonably anticipated, and had an adverse effect on the scheduled construction.



### § 15.1.7 Waiver of Claims for Consequential Damages

The Contractor and Owner waive Claims against each other for consequential damages arising out of or relating to this Contract. This mutual waiver includes

- .1 damages incurred by the Owner for rental expenses, for losses of use, income, profit, financing, business and reputation, and for loss of management or employee productivity or of the services of such persons; and
- .2 damages incurred by the Contractor for principal office expenses including the compensation of personnel stationed there, for losses of financing, business and reputation, and for loss of profit, except anticipated profit arising directly from the Work.

This mutual waiver is applicable, without limitation, to all consequential damages due to either party's termination in accordance with Article 14. Nothing contained in this Section 15.1.7 shall be deemed to preclude assessment of liquidated damages, when applicable, in accordance with the requirements of the Contract Documents.

### § 15.2 Initial Decision

§ 15.2.1 Claims, excluding those where the condition giving rise to the Claim is first discovered after expiration of the period for correction of the Work set forth in Section 12.2.2 or arising under Sections 10.3, 10.4, and 11.5, shall be referred to the Initial Decision Maker for initial decision. The Architect will serve as the Initial Decision Maker, unless otherwise indicated in the Agreement. Except for those Claims excluded by this Section 15.2.1, an initial decision shall be required as a condition precedent to mediation of any Claim. If an initial decision has not been rendered within 30 days after the Claim has been referred to the Initial Decision Maker, the party asserting the Claim may demand mediation and binding dispute resolution without a decision having been rendered. Unless the Initial Decision Maker and all affected parties agree, the Initial Decision Maker will not decide disputes between the Contractor and persons or entities other than the Owner.

§ 15.2.2 The Initial Decision Maker will review Claims and within ten days of the receipt of a Claim take one or more of the following actions: (1) request additional supporting data from the claimant or a response with supporting data from the other party, (2) reject the Claim in whole or in part, (3) approve the Claim, (4) suggest a compromise, or (5) advise the parties that the Initial Decision Maker is unable to resolve the Claim if the Initial Decision Maker lacks sufficient information to evaluate the merits of the Claim or if the Initial Decision Maker concludes that, in the Initial Decision Maker's sole discretion, it would be inappropriate for the Initial Decision Maker to resolve the Claim.

§ 15.2.3 In evaluating Claims, the Initial Decision Maker may, but shall not be obligated to, consult with or seek information from either party or from persons with special knowledge or expertise who may assist the Initial Decision Maker in rendering a decision. The Initial Decision Maker may request the Owner to authorize retention of such persons at the Owner's expense.

§ 15.2.4 If the Initial Decision Maker requests a party to provide a response to a Claim or to furnish additional supporting data, such party shall respond, within ten days after receipt of the request, and shall either (1) provide a response on the requested supporting data, (2) advise the Initial Decision Maker when the response or supporting data will be furnished, or (3) advise the Initial Decision Maker that no supporting data will be furnished. Upon receipt of the response or supporting data, if any, the Initial Decision Maker will either reject or approve the Claim in whole or in part.

§ 15.2.5 The Initial Decision Maker will render an initial decision approving or rejecting the Claim, or indicating that the Initial Decision Maker is unable to resolve the Claim. This initial decision shall (1) be in writing; (2) state the reasons therefor; and (3) notify the parties and the Architect, if the Architect is not serving as the Initial Decision Maker, of any change in the Contract Sum or Contract Time or both. The initial decision shall be final and binding on the parties but subject to mediation and, if the parties fail to resolve their dispute through mediation, to binding dispute resolution.

§ 15.2.6 Either party may file for mediation of an initial decision at any time, subject to the terms of Section 15.2.6.1.

§ 15.2.6.1 Either party may, within 30 days from the date of receipt of an initial decision, demand in writing that the other party file for mediation. If such a demand is made and the party receiving the demand fails to file for mediation within 30 days after receipt thereof, then both parties waive their rights to mediate or pursue binding dispute resolution proceedings with respect to the initial decision.

§ 15.2.7 In the event of a Claim against the Contractor, the Owner may, but is not obligated to, notify the surety, if any, of the nature and amount of the Claim. If the Claim relates to a possibility of a Contractor's default, the Owner may, but is not obligated to, notify the surety and request the surety's assistance in resolving the controversy.

§ 15.2.8 If a Claim relates to or is the subject of a mechanic's lien, the party asserting such Claim may proceed in accordance with applicable law to comply with the lien notice or filing deadlines.

### § 15.3 Mediation

§ 15.3.1 Claims, disputes, or other matters in controversy arising out of or related to the Contract, except those waived as provided for in Sections 9.10.4, 9.10.5, and 15.1.7, shall be subject to mediation as a condition precedent to binding dispute resolution.

§ 15.3.2 The parties shall endeavor to resolve their Claims by mediation which, unless the parties mutually agree otherwise, shall be administered by the American Arbitration Association in accordance with its Construction Industry Mediation Procedures in effect on the date of the Agreement. A request for mediation shall be made in writing, delivered to the other party to the Contract, and filed with the person or entity administering the mediation. The request may be made concurrently with the filing of binding dispute resolution proceedings but, in such event, mediation shall proceed in advance of binding dispute resolution proceedings, which shall be stayed pending mediation for a period of 60 days from the date of filing, unless stayed for a longer period by agreement of the parties or court order. If an arbitration is stayed pursuant to this Section 15.3.2, the parties may nonetheless proceed to the selection of the arbitrator(s) and agree upon a schedule for later proceedings.

§ 15.3.3 Either party may, within 30 days from the date that mediation has been concluded without resolution of the dispute or 60 days after mediation has been demanded without resolution of the dispute, demand in writing that the other party file for binding dispute resolution. If such a demand is made and the party receiving the demand fails to file for binding dispute resolution within 60 days after receipt thereof, then both parties waive their rights to binding dispute resolution proceedings with respect to the initial decision.

§ 15.3.4 The parties shall share the mediator's fee and any filing fees equally. The mediation shall be held in the place where the Project is located, unless another location is mutually agreed upon. Agreements reached in mediation shall be enforceable as settlement agreements in any court having jurisdiction thereof.

### § 15.4 Arbitration

§ 15.4.1 If the parties have selected arbitration as the method for binding dispute resolution in the Agreement, any Claim subject to, but not resolved by, mediation shall be subject to arbitration which, unless the parties mutually agree otherwise, shall be administered by the American Arbitration Association in accordance with its Construction Industry Arbitration Rules in effect on the date of the Agreement. The Arbitration shall be conducted in the place where the Project is located, unless another location is mutually agreed upon. A demand for arbitration shall be made in writing, delivered to the other party to the Contract, and filed with the person or entity administering the arbitration. The party filing a notice of demand for arbitration must assert in the demand all Claims then known to that party on which arbitration is permitted to be demanded.

§ 15.4.1.1 A demand for arbitration shall be made no earlier than concurrently with the filing of a request for mediation, but in no event shall it be made after the date when the institution of legal or equitable proceedings based on the Claim would be barred by the applicable statute of limitations. For statute of limitations purposes, receipt of a written demand for arbitration by the person or entity administering the arbitration shall constitute the institution of legal or equitable proceedings based on the Claim.

§ 15.4.2 The award rendered by the arbitrator or arbitrators shall be final, and judgment may be entered upon it in accordance with applicable law in any court having jurisdiction thereof.

§ 15.4.3 The foregoing agreement to arbitrate and other agreements to arbitrate with an additional person or entity duly consented to by parties to the Agreement, shall be specifically enforceable under applicable law in any court having jurisdiction thereof.

**§ 15.4.4 Consolidation or Joinder**

**§ 15.4.4.1** Subject to the rules of the American Arbitration Association or other applicable arbitration rules, either party may consolidate an arbitration conducted under this Agreement with any other arbitration to which it is a party provided that (1) the arbitration agreement governing the other arbitration permits consolidation, (2) the arbitrations to be consolidated substantially involve common questions of law or fact, and (3) the arbitrations employ materially similar procedural rules and methods for selecting arbitrator(s).

**§ 15.4.4.2** Subject to the rules of the American Arbitration Association or other applicable arbitration rules, either party may include by joinder persons or entities substantially involved in a common question of law or fact whose presence is required if complete relief is to be accorded in arbitration, provided that the party sought to be joined consents in writing to such joinder. Consent to arbitration involving an additional person or entity shall not constitute consent to arbitration of any claim, dispute or other matter in question not described in the written consent.

**§ 15.4.4.3** The Owner and Contractor grant to any person or entity made a party to an arbitration conducted under this Section 15.4, whether by joinder or consolidation, the same rights of joinder and consolidation as those of the Owner and Contractor under this Agreement.



# **Additions and Deletions Report for** **AIA® Document A201® – 2017**

This Additions and Deletions Report, as defined on page 1 of the associated document, reproduces below all text the author has added to the standard form AIA document in order to complete it, as well as any text the author may have added to or deleted from the original AIA text. Added text is shown underlined. Deleted text is indicated with a horizontal line through the original AIA text.

Note: This Additions and Deletions Report is provided for information purposes only and is not incorporated into or constitute any part of the associated AIA document. This Additions and Deletions Report and its associated document were generated simultaneously by AIA software at 08:02:46 ET on 05/19/2021.

## **PAGE 1**

Evansville Maintenance Garage  
15 Old Hwy 92  
Evansville, WI 53562

...

City of Evansville, WI  
31 S. Madison Street  
PO Box 529  
Evansville, WI 53536

...

Sketchworks Architecture, LLC  
7780 Elmwood Ave., Suite 208  
Middleton, WI 53562

## **Certification of Document's Authenticity**

**AIA® Document D401™ – 2003**

I, Brad M. Crowley, hereby certify, to the best of my knowledge, information and belief, that I created the attached final document simultaneously with its associated Additions and Deletions Report and this certification at 08:02:46 ET on 05/19/2021 under Order No. 0514486010 from AIA Contract Documents software and that in preparing the attached final document I made no changes to the original text of AIA® Document A201™ – 2017, General Conditions of the Contract for Construction, as published by the AIA in its software, other than those additions and deletions shown in the associated Additions and Deletions Report.

---

*(Signed)*

---

*(Title)*

---

*(Dated)*

**INSURANCE DATA**

Kathy Schwarz  
Schwarz Insurance  
1420 North Ridge Drive  
P.O. Box 40  
Prairie du Sac, WI 53578  
608.643.3385

**INSURANCE LIMITS**

**CNA Insurance**

**Continental Insurance Company**

Umbrella \$10,000,000  
Automobile Liability \$1,000,000

**Continental Casualty**

General Liability \$1,000,000/\$2,000,000  
Worker's Compensation Statutory Limits

**Columbia Casualty**

Professional Liability \$1,000,000

Insurance Certificates are available upon request.

**BANKING REFERENCE**

Benjamin L. Swanson – Business Banking Officer  
State Bank of Cross Plains  
1205 Main Street  
Cross Plains, WI 53528  
608.798.5257

---

**NOTES:**

Owner to provide All-Peril Builder's Risk Insurance, naming 1848 Construction, Inc. as named insured on the policy.

**ARTICLE 11 OTHER CONDITIONS OR PROVISIONS**

1. The Owner hereby represents that it is the Owner in fee or signed lessee of the premises whereon the improvements herein specified are to be made, having a deed or lease for the same.
2. WARRANTIES: See AIA Document A201 – General Conditions, Sections 3.5, 4.2.9, 9.3.3, 9.8.4, 9.9.1, 9.10.2, 9.10.4, 12.2.2, 15.1.2. THE FORGOING IS IN LIEU OF ALL OTHER WARRANTIES EXPRESSED, IMPLIED, OR STATUTORY AND CONTRACTOR NEITHER ASSUMES, NOT AUTHORIZES, ANY PERSON TO ASSUME FOR IT ANY OTHER OBLIGATION OR LIABILITY IN CONNECTION WITH THE WORK TO BE PERFORMED UNDER THE TERMS OF THIS CONTRACT.
3. All promises, understandings, or Contracts of any kind, to this Contract, not mentioned herein, are hereby expressly waived; and it is agreed that this instrument shall constitute the entire Contract between parties, and shall not be modified in any manner, except in writing signed by both parties.
4. AS REQUIRED BY THE WISCONSIN CONSTRUCTION LIEN LAW, 1848 CONSTRUCTION, INC. HEREBY NOTIFIES OWNER THAT PERSONS OR COMPANIES FURNISHING LABOR OR MATERIALS FOR THE CONSTRUCTION ON OWNER'S LAND MAY HAVE LIEN RIGHTS ON THE LAND AND ON THE BUILDINGS ON THAT LAND IF THEY ARE NOT PAID FOR SUCH LABOR OR MATERIALS. THOSE ENTITLED TO LIEN RIGHTS, IN ADDITION TO THE UNDERSIGNED BUILDER, 1848 CONSTRUCTION INC., ARE THOSE WHO CONTRACT DIRECTLY WITH THE OWNER OR THOSE WHO GIVE THE OWNER NOTICE WITHIN 60 DAYS AFTER THEY FIRST FURNISH LABOR OR MATERIALS FOR THE CONSTRUCTION. ACCORDINGLY, OWNER PROBABLY WILL RECEIVE NOTICES FROM THOSE WHO FURNISH LABOR OR MATERIALS FOR THE CONSTRUCTION, AND SHOULD GIVE A COPY OF EACH NOTICE RECEIVED TO HIS MORTGAGE LENDER, IF ANY. BUILDER AGREES TO COOPERATE WITH THE OWNER AND HIS LENDER, IF ANY, TO SEE THAT ALL POTENTIAL LIEN CLAIMANTS ARE DULY PAID.





**Architectural and Engineering Services Proposal for**  
**Evansville Water and Light Office Addition**

**June 16, 2021**

**Project Understanding**

We understand this project to be the design of a Pre engineered metal building addition.

The following constitutes some notable criteria that we understand:

- New space for city utility clerk and extra workstations, conference room
- Approximate floor plate of 44'-0" x 20'-0"
- Addition to be located in the inside corner of existing building
- Height of new roof to sit below existing
- New entrance and parking access
- Relocation of gas and water meters

**Schedule**

The schedule below is not guaranteed, rather, it is an approximate milestone completion target based upon our best analysis of the design, City entitlement, and permitting process.

We are flexible in our delivery methods to adjust to the Client's needs and can respond to an early fast-track design approach if necessary, in order to obtain early-start permits – pending the municipal entitlement process. Please feel free to contact us to discuss in more detail if needed.

**Milestone Schedule:**

Notice to Proceed:	6/23/2021
Complete Schematic Design:	7/7/2021
Complete Design Development:	7/28/2021
Submit Drawings for Plan Commission:	8/2/2021
Plan Commission Meeting:	9/7/2021
Complete Construction Documents:	9/13/2021
Complete Bidding & permitting:	10/13/2021
Begin Construction:	10/20/2021
Occupancy:	3/2/2021





## Services and Deliverables

The project will be sub-divided into the following design phases: Schematic Design, Design Development, Construction Documents and Construction Administration. Deliverables for each phase are listed in the following pages.

The following services will be provided (in no particular order) in accordance with the project schedule and phasing approach:

- Review, coordination of codes and submittals to regulatory agencies
- Observe and document existing property conditions that impact the project
- Make all necessary Neighborhood, Municipal and State submittals
- Attend the necessary meetings required to pursue local approvals, including:
  - Plan Commission (1 expected)
  - Common Council (1 expected)
- Architectural planning and design of new building structure
- Detailing of code-required items such as fire barriers, fire walls, egress and accessibility
- Structural engineering as required for complete documentation of entire new building
- Produce necessary design drawings and construction contract drawings for permits
- Produce project specifications in the drawings for materials and installation requirements
- Envelope energy calculations (ComCheck), sealed, for permitting
- Structural calculations, sealed, for permitting
- Distribute plans to the contractor for bidding and construction
- Conduct construction administration services as described in the deliverables list

NOT included in our services are the following (we understand that the Client will contract these services separately, if needed, though we can include this scope of work for an additional fee):

- Mechanical / HVAC design and engineering (assumed to be design-build delivery)
- Civil and Site Design and Engineering, and Landscape Design (assumed to be by Evansville's city engineer)
- Electrical and Tele-data design and engineering (assumed to be design-build delivery)
- Plumbing design (assumed to be design-build delivery)
- Fire protection design (assumed to be design-build delivery)
- Geotechnical / Sub-surface soils exploration
- Hazardous material survey, testing or evaluation of existing buildings or property
- Full analysis of any part of the site, adjacent sites, or existing structures which are not directly affected by this project (unless otherwise expressly stated in this proposal)
- Signage design or sign permit submittals are to be provided by others
- Computer generated 3D color rendering of the facility



## ***List of Expected Deliverables***

### **Schematic Design (SD):**

Multiple (2-3) design ideas will be presented for evaluation including:

- Architectural Site plan
- Floor plans
- Exterior Elevations
- Building sections
- Structural framing grid established, plans started
- computer generated 3D imagery of exterior design (schematic level)

### **Design Development (DD):**

A single design solution will be prepared and developed including:

- Architectural Site plan
- Floor plans
- Reflected ceiling plans
- Roof plan
- Exterior Elevations
- Building sections & Wall sections
- Structural framing grid established, plans started

### **Construction Documents (CD):**

Bidding and construction document stamped and sealed drawing set, including:

- Cover Sheet with general notes, abbreviations, key
- Architectural Site plan
- Floor plans (overall and enlarged)
- Emergency egress plans
- Reflected ceiling plans
- Roof plan
- Exterior elevations
- Building sections
- Wall sections
- Exterior and Interior details
- Interior and casework elevations
- Door schedule and details
- Finish schedule and details
- Structural foundation plan
- Structural notes and details
- Structural calculations
- Envelope energy calculations (ComCheck)



**Construction Administration:**

- Conduct 4 jobsite observations, or roughly once per month
- Review shop drawings and submittals
- Respond to “requests for information” (RFI) and other contractor requests
- Review monthly contractor pay applications
- Note: Changes to design drawings for any reason are considered additional service





## ***Hourly Rates for Additional Services***

Refer to "Terms and Conditions" in this document for hourly and reimbursable expense rates.

## ***Reimbursable Expenses***

- All printing, plotting and reproduction costs incurred shall be fully reimbursed by the Client.
- All postal / shipping / delivery charges will be fully reimbursed by the Client.
- All fees paid for agency submittals and reviews shall be fully reimbursed by the Client.
- Travel expenses for up to 4 trips to the project site are not considered reimbursable and will not be billed to the Client. Travel in excess of this shall be reimbursed at published mileage rates plus time.
- Communication fees / Telephone charges will not be considered reimbursable and will not be billed to the Client.
- In-house photography is not considered a reimbursable expense; professional photography, if requested, shall be fully reimbursed by the Client.



## **Client Provided Items**

It is anticipated that the Client will furnish the following, as such these are not included in our fee:

- Site survey of all properties affected by design and development, in electronic .dwg format.
- Geotechnical engineering / sub-surface soils exploration report.
- Hazardous material survey, testing and/or report of site and/or existing buildings as needed
- Local, Federal and State agency submittal fees, construction document examination fees, and building permit fees.
- Any desired materials list and /or color standards.
- Any and all equipment and/or material preferences.

## **Additional Notes**

Sketchworks Architecture, LLC does not guarantee municipal or neighborhood approval of this project. We will work to ensure compliance with all regulatory conditions while meeting the goals of the Client. Should this project ultimately not be approved for any reason, Sketchworks Architecture is still entitled to compensation for work performed.

The municipal approval process can at times be difficult to navigate the need to bridge Client goals and local neighborhood opinions. Should the design review and entitlement process require substantially more time than anticipated (meetings and deliverables listed herein), Sketchworks Architecture will be entitled to additional compensation for extra approval design, submittal and meeting time.

Sketchworks Architecture, LLC and its sub-consultants carry professional liability insurance coverage in good standing. Certificates of insurance are available upon request.

This proposal includes the "Terms and Conditions" listed on the following pages.

If you find this proposal acceptable, please sign and date one copy of this proposal and return to Sketchworks Architecture, LLC as a notice to proceed. Additionally, if an email notice to proceed is given, it is considered an acknowledgement and authorization of this agreement, and to the terms and conditions listed herein unless written otherwise.

## **Authorized Signature**

A handwritten signature in black ink, appearing to read "Steve J. Shulfer", is written over a horizontal line.

Steve J. Shulfer, AIA, LEED AP  
Partner / CEO

6/16/2021

\_\_\_\_\_  
date

\_\_\_\_\_  
Accepted by:

\_\_\_\_\_  
date





## Terms and Conditions

- 1. Performance of Services:** The Architect shall perform the services outlined in the Project Proposal (the "Services") in exchange for payment by the Owner of the amount set forth in the Proposal in accordance with the payment terms set forth below.
- 2. Access to Site:** Unless otherwise stated, the Architect will have full access to the site during normal business hours for activities necessary for the performance of the Services.
- 3. Retainer/Billing/Payment:** The Owner agrees to pay the Architect for all services performed and all costs incurred. Invoices for the Architect's services shall be submitted, at the Architect's option, either upon completion of such services or on a monthly basis. Invoices shall be due and payable upon receipt. If any invoice is not paid within 30 days, the Architect may, without waiving any claim or right against the Owner, and without liability whatsoever to the Owner, suspend, or terminate the performance of services. Accounts unpaid 30 days after the invoice date shall be subject to a monthly service charge of 1.5% (or the maximum legal rate allowed by Wisconsin law) on the unpaid balance. In the event Architect deems it necessary to take legal action to collect amounts owed by Owner under this Agreement, Architect shall be entitled to recover the reasonable attorneys' fees it incurred in taking such actions.
- 4. Payment methods:** Cash, Check, ACH, or credit card payments will be accepted. Credit card payments will incur a 2.9% surcharge. However, credit card payments made within 15 days of invoice date will be discounted to waive the credit card processing fee.
- 5. Notice of Lien Rights:** AS REQUIRED BY THE WISCONSIN CONSTRUCTION LIEN LAW, ARCHITECT HEREBY NOTIFIES OWNER THAT PERSONS OR COMPANIES PERFORMING, FURNISHING OR PROCURING LABOR, SERVICES, MATERIALS, PLANS OR SPECIFICATIONS FOR THE CONSTRUCTION ON OWNER'S LAND MAY HAVE LIEN RIGHTS ON OWNER'S LAND AND BUILDINGS IF NOT PAID. THOSE ENTITLED TO LIEN RIGHTS, IN ADDITION TO THE UNDERSIGNED ARCHITECT, ARE THOSE WHO CONTRACT DIRECTLY WITH THE OWNER OR THOSE WHO GIVE THE OWNER NOTICE WITHIN 60 DAYS AFTER THEY FIRST PERFORM, FURNISH OR PROCURE LABOR, SERVICES, MATERIALS, PLANS OR SPECIFICATIONS FOR THE CONSTRUCTION. ACCORDINGLY, OWNER PROBABLY WILL RECEIVE NOTICES FROM THOSE WHO PERFORM, FURNISH OR PROCURE LABOR, SERVICES, MATERIALS, PLANS OR SPECIFICATIONS FOR THE CONSTRUCTION, AND SHOULD GIVE A COPY OF EACH NOTICE RECEIVED TO THE MORTGAGE LENDER, IF ANY. ARCHITECT AGREES TO COOPERATE WITH THE OWNER AND OWNER'S LENDER, IF ANY, TO SEE THAT ALL POTENTIAL LIEN CLAIMANTS ARE DULY PAID.
- 6. Indemnification:** The Owner shall, to the fullest extent permitted by law, indemnify, defend and hold harmless the Architect, his or her members, officers, directors, employees, agents and sub-consultants from and against all damages, losses, liabilities and costs, including reasonable attorney's fees and litigation costs, arising out of or in any way related to the performance of the services under this Agreement, excepting only those damages,



losses, liabilities or costs solely attributable to the negligence or willful misconduct of the Architect.

- 7. Waiver:** Both parties waive consequential damages for claims and disputes arising out of or relating to this Agreement. This mutual waiver is applicable to all consequential damages, including consequential damages due to either party's termination in accordance with this Agreement.
- 8. Information for the Sole Use and Benefit of the Owner:** All opinions and conclusions of the Architect, whether written or oral, and any plans, specifications or other documents and services provided by the Architect are to be used only for the planning and construction of the Project and are not to be used or provided to any other person or entity for any other purpose without the prior written consent of the Architect. Nothing contained in the Agreement shall create a contractual relationship with, or a cause of action in favor of any third party against, either the Architect or the Owner.
- 9. Existing Conditions.** With respect to any Services to be provided by Architect relating to an existing structure, Architect's drawings of the existing structure are intended to generally represent the condition of the structure and may not be accurate depictions of the current condition. Architect shall not be liable for any damages or losses relating to design issues on the Project that arise as a result of existing conditions of which Architect did not have actual knowledge.
- 10. Limitation of Liability:** In recognition of the relative risks, rewards and benefits of the project to both the Owner and the Architect, the risks have been allocated such that the Owner agrees that, to the fullest extent permitted by law, the Architect's total liability to the Owner for any and all claims or causes of action including, but not limited to, negligence, errors, omissions, strict liability, breach of contract or breach of warranty, and are limited to the total fees paid to Architect under this Agreement.
- 11. Ownership of Documents:** All documents, photographs, models, computer files and drawings that are prepared or produced by the Architect under this Agreement are instruments of the Architect's professional service and shall remain the property of the Architect. Providing that Owner is not in default of this Agreement, Architect grants Owner a limited license to use and reproduce these instruments to the extent necessary for the sole purpose of constructing the Project. Owner may not use these instruments for any other purpose without the prior written consent of the Architect. Owner shall indemnify, defend, and hold harmless Architect, and its members, officers, directors, employees, agents and sub-consultants for any and all damages, losses, liabilities and costs that arise from or relate to Owner's improper or unauthorized use of the instruments of service.
- 12. Delay:** Architect shall provide its Services in accordance with the schedule agreed upon by the parties. If the Architect is delayed at any time due to causes beyond its control or other reasons justifying the delay, the Architect shall be entitled to an extension of time for performing such Services. If the delay results in additional costs to the Architect, the Architect shall also be entitled to an adjustment to the contract price.





- 13. Changes in Services:** In the event of a change in the Services to be performed under this Agreement, Architect shall be entitled to an appropriate adjustment in compensation and schedule. A change in Services shall include, but is not limited to, a change by Owner in the scope of the Project, the failure of the Owner to timely provide necessary information to the Architect, a change in the applicable building codes or law, or a change in the size or budget of the Project.
- 14. Project Inspection:** Architect shall inspect the Project as required by the Proposal. Architect's inspections shall be for the sole purpose of evaluating whether in general the work is being performed in a manner consistent with the Project plans and specifications. Architect shall not be responsible for determining the quality or quantity of the work or for the construction methods, techniques, sequences, or safety precautions used in performing the work.
- 15. Hazardous Materials:** Architect is not liable for the discovery, presence, or removal of hazardous materials or toxic substances in any form on the Project site.
- 16. Dispute Resolution:** All claims or disputes arising out of or relating to this Agreement or the Services to be provided by the Architect hereunder shall be submitted to mediation. The Owner and the Architect agree to include a similar mediation requirement in their contracts with contractors, sub-contractors, sub-consultants, suppliers, and fabricators. In the event the parties are unable to resolve their claims or disputes through mediation, all claims or disputes shall be brought in Dane County Circuit Court for the State of Wisconsin, and both parties hereby submit to the jurisdiction of such court.
- 17. Termination of Services:** This Agreement may be terminated at any time by either party should the other party fail to perform its obligations hereunder. In the event of termination for any reason whatsoever, the Owner shall pay the Architect for all services rendered to the date of termination, and all reimbursable expenses incurred prior to termination, along with reasonable termination expenses incurred by the Architect as the result of termination.
- 18. Warranty:** EXCEPT AS EXPRESSLY STATED IN THE PROPOSAL, ARCHITECT DOES NOT MAKE ANY EXPRESS WARRANTIES WITH RESPECT TO THE WORK AND HEREBY EXPRESSLY DISCLAIMS ALL IMPLIED WARRANTIES, WHETHER OF MERCHANTABILITY, FITNESS OR OTHERWISE.
- 19. Applicable Law:** This Agreement shall be governed in all respects by the laws of the State of Wisconsin.
- 20. Modifications:** This Agreement shall not be modified except in a written document signed by both parties.
- 21. Severability:** In the event any term of this Agreement is found to be unenforceable or prohibited by law, that term shall be ineffective and severed from the Agreement and the rest of the terms and provisions of this Agreement shall remain in full force and effect.
- 20. Assignment:** Neither party may assign this Agreement without the written consent of the other.



**21. Fee Schedule:** The following fee schedule shall apply for all reimbursable expenses and any additional services work:

**Staff Hourly Rates**

Partner/Architect:	\$150 / hour
Project Architect:	\$120 / hour
Project Manager:	\$120 / hour
Architectural Designer	\$100 / hour
Interior Designer:	\$100 / hour
Administrative Support:	\$ 85 / hour
Sub-Consultants:	(as per consultant rate-sheet)

Sub-consultant services: Mark up of sub-consultant fees to be 8%

Printing costs: Large-format B&W printing to be \$1.00 per square foot \*  
 Large-format Color printing to be \$2.50 per square foot  
 Small-format B&W printing to be \$.085 per 8-1/2x11 sheet  
 Small-format B&W printing to be \$.25 per 11x17 sheet  
 Small-format Color printing to be \$.25 per 8-1/2x11 sheet  
 Small-format Color printing to be \$.50 per 11x17 sheet

\* Discounts may apply for large-volume printing, not to be less than outsourced printing vendor cost plus 15% SA mark-up.

Postage and shipping costs: Claimed at cost with no mark-up

Photography: No charge (unless special printing required)

Phone / Fax / Data: No charge

Mileage: \$0.61 per mile when applicable

Per diem meal expenses: Claimed at cost, not to exceed \$35 per day  
 (one meal per six hours of total travel/meeting time)

Travel Lodging: \$100.00 per night per person when required  
 (only if travel exceeds 4 hours drive time, one way)

# Memorandum

**To:** Municipal Services – Finance and Labor Relations – Common Council  
**From:** Jason Sergeant, Administrator/Finance Director - Julie Roberts, Treasurer  
**Date:** 06/23/2021  
**Re:** Stormwater Utility Rate Study

---

## **Background**

The City's Financial Advisor at Ehlers, informed that stormwater revenue bonds require debt service coverage of 1.10% (this is operating revenue divided by the total debt service for the fund). Revenue bonds cannot be used for the upcoming borrowing. Doing so would drop our ratio to as low as 0.72%. As a result, borrowing for stormwater will be done as general obligation debt. Simply put, the revenues of the stormwater fund are not covering the expenses. Fund balance will be utilized for the difference making it precarious to use this for upcoming projects.

## **Recommendations**

Staff recommends that we engage Ehlers to do a Stormwater rate study. The cost for this will be \$4,500. It will include an initial information request and review, utility rate study and a long range cash flow analysis. This will tell us where our rates need to be to cover our expenses, including upcoming stormwater borrowings that are currently in the capital improvement plan. If information is provided to them in a timely manner this could be completed in 4-5 weeks.

## **Budget Impact**

\$4,500 will be paid out the stormwater balance.

## **Looking Forward**

Funds should be reviewed each year to make sure that expenses are not out pacing revenues. If they are, steps should be taken to remedy this.

June 16, 2021

Julie Roberts, Accountant  
Jason Sergeant, City Administrator  
City of Evansville, Wisconsin  
31 S Madison St  
PO Box 529  
Evansville, WI 53536-0076

Re: Written Municipal Advisor Client Disclosure with the City of Evansville ("Client") for Test Year 2021 Stormwater Utility Rate Study ("Project" Pursuant to MSRB Rule G-42)

Dear Julie and Jason:

As a registered Municipal Advisor, we are required by Municipal Securities Rulemaking Board (MSRB) Rules to provide you with certain written information and disclosures prior to, upon or promptly, after the establishment of a municipal advisory relationship as defined in Securities and Exchange Act Rule 15Ba1-1. To establish our engagement as your Municipal Advisor, we must inform you that:

1. When providing advice, we are required to act in a fiduciary capacity, which includes a duty of loyalty and a duty of care. This means we are required to act solely in your best interest.
2. We have an obligation to fully and fairly disclose to you in writing all material actual or potential conflicts of interest that might impair our ability to render unbiased and competent advice to you. We are providing these and other required disclosures in **Appendix A** attached hereto.
3. As your Municipal Advisor, Ehlers shall provide this advice and service at such fees, as described within **Appendix B** attached hereto.

This documentation and all appendices hereto shall be effective as of its date unless otherwise terminated by either party upon 30 days written notice to the other party.

During the term of our municipal advisory relationship, this writing might be amended or supplemented to reflect any material change or additions.

We look forward to working with you on this Project.

Sincerely,

Ehlers

A handwritten signature in black ink, appearing to read 'Brian Roemer', written over a horizontal line.

Brian Roemer  
Municipal Advisor

---

<sup>1</sup> This document is intended to satisfy the requirements of MSRB Rule G-42(b) and Rule G-42(c).

## **Appendix A**

### **Disclosure of Conflicts of Interest/Other Required Information**

#### **Actual/Potential Material Conflicts of Interest**

Ehlers has no known actual or potential material conflicts of interest that might impair its ability either to render unbiased and competent advice or to fulfill its fiduciary duty to Client.

#### **Other Engagements or Relationships Impairing Ability to Provide Advice**

Ehlers is not aware of any other engagement or relationship Ehlers has that might impair Ehlers' ability to either render unbiased and competent advice to or to fulfill its fiduciary duty to Client.

#### **Affiliated Entities**

Ehlers offers related services through two affiliates of Ehlers, Bond Trust Service Corporation (BTSC) and Ehlers Investment Partners (EIP). BTSC provides paying agent services while Ehlers Investment Partners (EIP) provides investment related services and bidding agent service. Ehlers and these affiliates do not share fees. If either service is needed in conjunction with an Ehlers municipal advisory engagement, Client will be asked whether or not they wish to retain either affiliate to provide service. If BTSC or EIP are retained to provide service, a separate agreement with that affiliate will be provided for Client's consideration and approval.

#### **Solicitors/Payments Made to Obtain/Retain Client Business**

Ehlers does not use solicitors to secure municipal engagements; nor does it make direct or indirect payments to obtain or retain Client business.

#### **Payments from Third Parties**

Ehlers does not receive any direct or indirect payments from third parties to enlist Ehlers recommendation to the Client of its services, any municipal securities transaction or any financial product.

#### **Payments/Fee-splitting Arrangements**

Ehlers does not share fees with any other parties and any provider of investments or services to the Client. However, within a joint proposal with other professional service providers, Ehlers could be the contracting party or be a subcontractor to the contracting party resulting in a fee splitting arrangement. In such cases, the fee due Ehlers will be identified in a Municipal Advisor writing and no other fees will be paid to Ehlers from any of the other participating professionals in the joint proposal.

#### **Municipal Advisor Registration**

Ehlers is registered with the Securities and Exchange Commission (SEC) and Municipal Securities Rulemaking Board (MSRB).

#### **Material Legal or Disciplinary Events**

Neither Ehlers nor any of its officers or municipal advisors have been involved in any legal or disciplinary events reported on Form MA or MA-I nor are there any other material legal or disciplinary events to be reported. Ehlers' application for permanent registration as a Municipal Advisor with the (SEC) was granted on July 28, 2014 and contained the information prescribed under Section 15B(a)(2) of the Securities and Exchange Act of 1934 and rules thereunder. It did not list any information on legal or disciplinary disclosures.

Client may access Ehlers' most recent Form MA and each most recent Form MA-I by searching the Securities and Exchange Commission's EDGAR system (currently available at <http://www.sec.gov/edgar/searchedgar/companysearch.html>) and searching under either our Company Name (Ehlers & Associates, Inc.) or by using the currently available "Fast Search" function and entering our CIK number (0001604197).

Ehlers has not made any material changes to Form MA or Form MA-I since that date.

#### **Conflicts Arising from Compensation Contingent on the Size or Closing of Any Transaction**

The forms of compensation for municipal advisors vary according to the nature of the engagement and requirements of the client. Compensation contingent on the size of the transaction presents a conflict of interest because the advisor may have an incentive to advise the client to increase the size of the securities issue for the purpose of increasing the advisor's compensation. Compensation contingent on the closing of the transaction presents a conflict because the advisor may have an incentive to recommend unnecessary financings or recommend financings that are disadvantageous to the client. If the transaction is to be delayed or fail to close, an advisor may have an incentive to discourage a full consideration of such facts and circumstances, or to discourage consideration of alternatives that may result in the cancellation of the financing or other transaction.

Any form of compensation due a Municipal Advisor will likely present specific conflict of interests with the Client. If a Client is concerned about the conflict arising from Municipal Advisor compensation contingent on size and/or closing of their transaction, Ehlers is willing to discuss and provide another form of Municipal Advisor compensation. The Client must notify Ehlers in writing of this request within 10 days of receipt of this Municipal Advisor writing.

#### **MSRB Contact Information**

The website address of the MSRB is [www.msrb.org](http://www.msrb.org). Posted on the MSRB website is a municipal advisory client brochure that describes the protections that may be provided by MSRB rules and how to file a complaint with the financial regulatory authorities.

## Appendix B Stormwater User Rate Study

### Scope of Service

The City of Evansville (“Client”) has requested that Ehlers prepare a user rate study for its stormwater utility. (“Project”). Ehlers proposes and agrees to provide the following scope of services:

#### Phase I – Information Request and Review

- Request and review the following:
  - Current schedule of stormwater user rates (if newer version than Resolution #2016-25 exists).
  - Annual audits for the past three years (we currently have this information).
  - 2020 Year end actual expenses and revenues for utility (unaudited is fine).
  - Current year budget for utility.
  - Current annual debt service schedules for existing utility debt (we currently have this information).
  - Any available capital improvement plan documents for utility.
  - Detailed stormwater billing records for the past 12-month period showing billed revenues by rate category (Variable/Non-variable) and number of customers.
  - Current number of Equivalent Runoff Units (ERUs) for residential and non-residential customer classes.
  - Any available information on upcoming developments and population growth over the study planning period that would increase the customer base and usage, or conversely any information on customers reducing usage or moving out of the municipality.

#### Phase II – Utility Rate Study Update

- Stormwater Rate Study
  - Based on the available budget, debt and asset detail, develop the revenue requirements for the utility under a cash-based or utility-based method.
  - Calculate the user rates per ERU for the test year and prepare a comparison of current and proposed user rates.
  - Prepare a cash flow analysis for the test year ensuring user rate adequacy.
- User Rate Comparison
  - Develop a comparison of existing and proposed user rates for example properties by customer class.
  - Develop a comparison of existing and proposed user rates to other communities (if requested).
- Report and Presentation
  - Prepare a report including all project tables and a brief executive summary describing the findings and recommendations.

- Review the report with staff and make any appropriate changes.
- Prepare a final report and submit via PDF or paper copy
- Prepare and present the report and findings to the Common Council or other designated committee.

**Phase III – Long Range Cash Flow Analysis**

- Prepare separate detailed cash flow analysis for both utilities with the following:
  - Development of annual operating expenses for the utility using an assumed rate of inflation based on historical expenses and discussions with staff.
  - Actual annual debt service expenses for existing utility debt.
  - The planned debt service for the stormwater utility upgrades taking into consideration available and minimum recommended reserves, existing debt and existing revenue bond covenants if applicable.
  - Project out revenues and identify projected user rate increases to meet all financial obligations of the utility in future years.
  - Meet with staff to discuss and review the analysis.

**Compensation**

In return for the services set forth in the “Scope of Service,” Client agrees to compensate Ehlers on an hourly not to exceed basis as follows:

<b>Service</b>	<b>Fee</b>
<u>Stormwater</u>	
Stormwater Rate Study	\$ 4,500
<b>Total</b>	<b>\$ 4,500</b>

For any service directed by Client and not covered by this, or another applicable Appendix, Ehlers will bill Client at an hourly rate that is dependent upon the task/staff required to meet Client request at no less than \$125.00/hour and not to exceed \$300.00/hour.

**Payment for Services**

Ehlers will invoice Client each month for the work completed in the prior month. Our fees include our normal travel, printing, computer services, and mail/delivery charges. The invoice is due and payable upon receipt by the Client.

**Client Engagement**

The above Proposal is hereby accepted by the City of Evansville, Wisconsin, by its authorized officer:

---

Signed \_\_\_\_\_ Title \_\_\_\_\_ Date \_\_\_\_\_



Customer Number	Group Code	April Data	
Number	Balance		
22-1500-03	1,328.72	PORTER	No Info for SDC
22-4060-09	1,984.70	MAGNOLIA	No Info for SDC
23-2295-00	1,987.41	MAGNOLIA	No Info for SDC
24-2625-00	20.12	BROOKLYN	Bankruptcy
24-3509-23	184.48	BROOKLYN	No Info for SDC
24-3518-14	609.82	BROOKLYN	No Info for SDC
25-2260-00	365.66	UNION	Trailer Gone No Info for SDC
25-5560-00	130.52	UNION	Trailer Sold No Info for SDC
25-5560-02	318.33	UNION	Trailer Sold No Info for SDC
25-5560-03	173.57	UNION	Trailer Sold No Info for SDC
25-5700-03	200	UNION	Trailer Sold No Info for SDC
25-6360-12	26.16	UNION	Faud Case Too Small for SDC
25-6360-13	53.92	UNION	Faud Case No Info for SDC
26-1090-06	78.91	MAGNOLIA	Rental Trailer No Info for SDC
26-1190-01	446.73	MAGNOLIA	Trailer Gone No Info for SDC
26-1240-00	147.28	MAGNOLIA	Trailer Gone No Info for SDC
26-1340-00	295.56	MAGNOLIA	Trailer Sold No Info for SDC
26-3220-03	538.89	UNION	Deseased/Rental Trailer No Info for SDC
26-3230-04	124.56	UNION	Trailer Rental No Info for SDC
26-3240-04	1,778.49	UNION	Trailer Rental No Info for SDC
26-3390-04	250.75	UNION	Trailer Sold No Info for SDC
26-3410-06	411.88	UNION	Trailer Rental No Info for SDC
26-3460-01	26.24	UNION	Trailer Rental Too Small for SDC
26-3500-03	24.05	UNION	Trailer Sold Too Small for SDC
26-3650-02	159.37	UNION	Trailer Sold No Info for SDC
<b>11,666.12</b>			

Customer Number	Group Code	June Data	
Number	Balance		
22-1500-03	\$ 1,328.72	PORTER	No Info for SDC
	0 \$ -		
22-4060-09	\$ 1,984.70	MAGNOLIA	No Info for SDC
23-2295-00	\$ 1,987.41	MAGNOLIA	No Info for SDC
24-2625-00	\$ 20.12	BROOKLYN	Bankruptcy
24-3509-23	\$ 184.48	BROOKLYN	No Info for SDC
24-3518-14	\$ 609.82	BROOKLYN	No Info for SDC
25-5560-00	\$ 130.52	UNION	Trailer Gone
25-5560-02	\$ 318.33	UNION	Trailer Sold
25-5560-03	\$ 173.57	UNION	Trailer Sold
25-5700-03	\$ 200.00	UNION	Trailer Sold
25-6360-12	\$ 26.16	UNION	Faud Case
	0 \$ -		
26-1090-06	\$ 78.91	MAGNOLIA	Rental Trailer
26-1190-01	\$ 446.73	MAGNOLIA	Trailer Gone
26-1240-00	\$ 147.28	MAGNOLIA	Trailer Gone
26-1340-00	\$ 295.56	MAGNOLIA	Trailer Sold
26-3220-03	\$ 538.89	UNION	Deseased/Rental Trailer
26-3230-04	\$ 124.56	UNION	Trailer Rental
26-3390-04	\$ 250.75	UNION	Trailer Rental
26-3410-06	\$ 411.88	UNION	Trailer Rental
26-3500-03	\$ 24.05	UNION	Trailer Sold
26-3650-02	\$ 159.37	UNION	Trailer Sold
<b>\$ 9,441.81</b>			

There is a way to put Leins on Trailers but it is a long process  
Some of the trailers are rentals so I am still looking into this.

---

*WPPI ESR Report*

---

- Two new solar applications were approved. One in Evansville and one in Brooklyn.
- Starting to meet Key Accounts in person!
- New rates for the Choose Renewable program is being pushed to 8/1 per the WPSC. Would like to discuss how we want to market the new rate.
- Flyer developed for Customer Appreciation Event, planning to go out with June's bills in July.